

Service  
Service  
Service

MD1.2E  
AA

For Service Manuals Contact  
MAURITRON TECHNICAL SERVICES  
8 Cherry Tree Rd, Chinnor  
Oxon OX9 4QY  
Tel:- 01844-351894 Fax:- 01844-352554  
Email:- enquiries@mauritron.co.uk

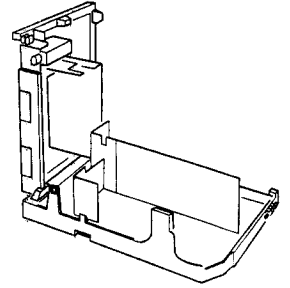

# Service Manual

Contents	Page	Contents	Page
1. Technical specifications	2	<i>Electrical diagrams and PWB-layouts</i>	<i>Diagram PWB</i>
2. Connection facilities and Chassis overview	2	Synchronisation (Schéma B3)	21 18
3. Safety instructions for repairs, Maintenance instructions, Warnings and Notes	3	IF sound (Schéma B4)	21 18
4. Mechanical instructions	4	Euroconnector 1 (Schéma B5)	22 18
5. Block diagram	6	Euroconnector 2 (Schéma B6)	22 18
Testpoint overview	7	Controls (Schéma B7)	23 18
Wiring diagram	8	Connections audio module (Schéma B8)	24 18
6. Service Modes, DST, Error messages, Protections, Faultfinding and Repair tips	8	Teletext (Schéma B9)	24 18
7. <i>Electrical diagrams and PWB-layouts</i>	<i>Diagram PWB</i>	CRT panel (Schéma C)	25 25
Supply voltage diagram	12	Audio module (Schéma D1)	26 27
Power supply 21" (Schéma A1)	13 14	Nicam L module (Schéma D2)	27 27
Power supply > 21" (Schéma A1)	15 14	CTI/Black Stretch panel (Schéma F)	28 29
Horizontal output (Schéma A2)	16 14	N/S panel (Schéma G)	29 29
Vertical output (Schéma A3)	17 14	Mains/RC5/LED panel (Schéma I)	30 30
Audio amplifier (Schéma A4)	17 14	Control and Input/Output (Schéma J)	31 31
Tuner + IF (Schéma B1)	19 18	8. Electrical alignments	32
Video processing (Schéma B2)	20 18	10. Directions for use	34
		11. List of abbreviations	37
		12. Spare parts lists	39

Copyright 1996 Philips Consumer Electronics B.V. Eindhoven, The Netherlands. All rights reserved. No part of this publication may be reproduced, stored in a retrieval system or transmitted, in any form or by any means, electronic, mechanical, photocopying, or otherwise without the prior permission of Philips.



# 1. Technical specifications

Mains voltage	: 220-240V AC (±10%)
Power consumption	
nominal output power (Watt)	: 100 (21" 90°); 130 (110° SF 4:3); 150 (110° SF 16:9)
peak output power (Watt)	: 160 (21" 90°); 180 (110° SF 4:3); 220 (110° SF 16:9)
standby (Watt)	: 3 (±10%)
Mains frequency	: 50 Hz (±10%)
Pull-in range colour synchronisation	: > ± 300Hz
Pull-in range horizontal synchronisation	: > ± 600Hz

# 2. Connection facilities and Chassis overview

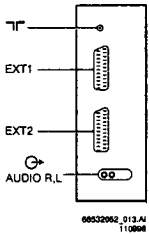

Rear connections

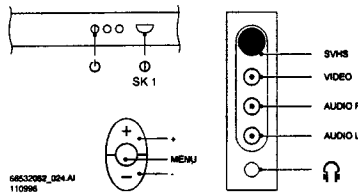

Front + Top control + Side I/O

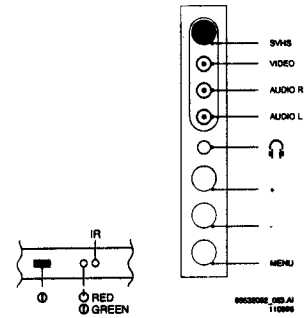

Front + Side control + Side I/O

## Specification of the terminal sockets

### REAR

**EXT1 - CVBS (in/out) + RGB (in) - tuner at output**

- |   |
|---|
| 1 - Audio ⊕ R (0.5V <sub>RMS</sub> ≤ 1kΩ)                       |
| 2 - Audio ⊖ R (0.2-2V <sub>RMS</sub> ≥ 10kΩ)                    |
| 3 - Audio ⊕ L (0.5V <sub>RMS</sub> ≤ 1kΩ)                       |
| 4 - Audio ⊥   |
| 5 - Blue ⊥  |
| 6 - Audio ⊖ L (0.2-2V <sub>RMS</sub> ≥ 10kΩ)                    |
| 7 - Blue ⊖ (0,7V <sub>pp</sub> /75Ω)                            |
| 8 - CVBS status(0-2V: INT; 4,5-7V: EXT1-16/9; 9.5-12V:EXT1-4/3) |
| 9 - Green ⊥   |
| 10 -  |
| 11 - Green ⊖ (0,7V <sub>pp</sub> /75Ω)                          |
| 12 -  |
| 13 - Red ⊥  |
| 14 - RGB status ⊥   |
| 15 - Red ⊖ (0,7V <sub>pp</sub> /75Ω)                            |
| 16 - RGB status (0-0,4V: INT;1-3V: EXT1/75Ω)                    |
| 17 - CVBS ⊥   |
| 18 - CVBS ⊥   |
| 19 - CVBS ⊕ (1V <sub>pp</sub> /75Ω)                             |
| 20 - CVBS ⊖ (1V <sub>pp</sub> /75Ω)                             |
| 21 - Earth screen   |

**EXT2 - CVBS (in/out) + SVHS (in) - Input: EXT2 then output = tuner; input: other then output = input**

- |   |
|---|
| 1 - Audio ⊕ R (0.5V <sub>RMS</sub> ≤ 1kΩ)                         |
| 2 - Audio ⊖ R (0.2-2V <sub>RMS</sub> ≥ 10kΩ)                      |
| 3 - Audio ⊕ L (0.5V <sub>RMS</sub> ≤ 1kΩ)                         |
| 4 - Audio ⊥   |
| 5 -   |
| 6 - Audio ⊖ L (0.2-2V <sub>RMS</sub> ≥ 10kΩ)                      |
| 7 -   |
| 8 - CVBS status ⊖ (0-2V: INT; 4,5-7V: EXT2-16/9;9.5-12V:EXT2-4/3) |
| 9 -   |
| 10 -  |
| 11 -  |
| 12 -  |
| 13 - C ⊥  |
| 14 -  |
| 15 - C ⊖ (300mV <sub>pp</sub> /75Ω)                               |
| 16 -  |
| 17 - CVBS ⊥   |
| 18 - CVBS ⊥   |
| 19 - CVBS ⊕ (1V <sub>pp</sub> /75Ω)                               |
| 20 - CVBS/Y ⊖ (1V <sub>pp</sub> /75Ω)                             |
| 21 - Earth screen   |

### Cinch - audio out

- ⊕ CINCH Audio L (red) ⊕ (0.5V<sub>RMS</sub> < 1kΩ)
- ⊖ CINCH Audio R (white) ⊕ (0.5V<sub>RMS</sub> < 1kΩ)

### FRONT

#### Audio/video in

- ⊖ CINCH CVBS ⊖ (1V<sub>pp</sub>/75Ω)
- ⊖ CINCH Audio L (red) ⊖ (2V<sub>RMS</sub> ≥ 10kΩ)
- ⊖ CINCH Audio R (white) ⊖ (2V<sub>RMS</sub> ≥ 10kΩ)

#### Headphone

⊕ ⊖ ⊕ 8-600Ω

#### SVHS

- |                                   |
|-----------------------------------|
| 1 - ⊥                             |
| 2 - ⊥                             |
| 3 - Y ⊖ (1V <sub>pp</sub> /75Ω)   |
| 4 - C ⊖ (0,3V <sub>pp</sub> /75Ω) |

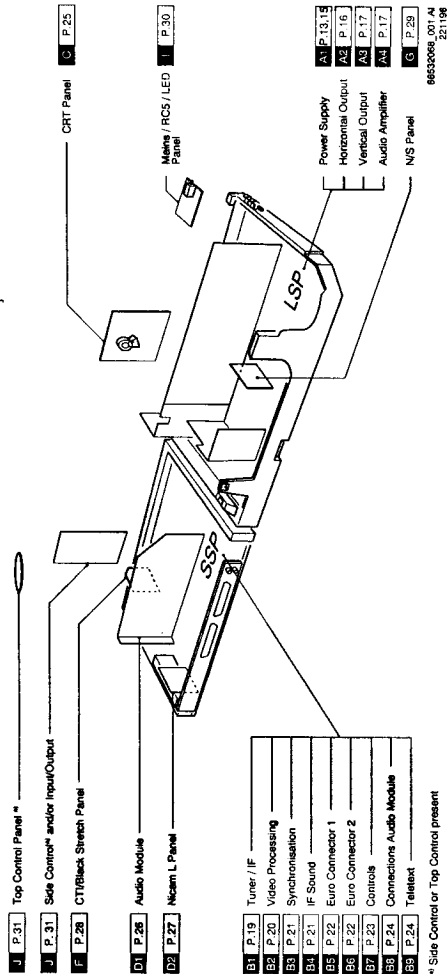

\* Side Control or \* Top Control present

### 3. Safety instructions for repairs, Maintenance instructions, Warnings and Notes

#### Safety instructions for repairs

1. Safety regulations require that during a repair:
  - the set should be connected to the mains via an isolating transformer;
  - safety components, indicated by the symbol ▲ should be replaced by components identical to the original ones;
  - when replacing the CRT, safety goggles must be worn.
2. Safety regulations require that after a repair the set must be returned in its original condition. In particular attention should be paid to the following points:
  - As a strict precaution, we advise you to resolder the solder joints through which the horizontal deflection current is flowing, in particular:
    - all pins of the line output transformer (LOT);
    - fly-back capacitor(s);
    - S-correction capacitor(s);
    - line output transistor;
    - pins of the connector with wires to the deflection coil;
    - other components through which the deflection current flows.

- Note:**  
This resoldering is advised to prevent bad connections due to metal fatigue in solder joints and is therefore only necessary for television sets older than 2 years.
- The wire trees and EHT cable should be routed correctly and fixed with the mounted cable clamps.
  - The insulation of the mains lead should be checked for external damage.
  - The mains lead strain relief should be checked for its function in order to avoid touching the CRT, hot components or heat sinks.
  - The electrical DC resistance between the mains plug and the secondary side should be checked (only for sets which have a mains isolated power supply). This check can be done as follows:
    - unplug the mains cord and connect a wire between the two pins of the mains plug;
    - set the mains switch to the on position (keep the mains cord unplugged!);
    - measure the resistance value between the pins of the mains plug and the metal shielding of the tuner or the aerial connection on the set. The reading should be between 4.5 MΩ and 12 MΩ;
    - switch off the TV and remove the wire between the two pins of the mains plug.
  - The cabinet should be checked for defects to avoid touching of any inner parts by the customer.

#### Maintenance instructions

- It is recommended to have a maintenance inspection carried out by a qualified service employee. The interval depends on the usage conditions:
- when the set is used under normal circumstances, for example in a living room, the recommended interval is 3 to 5 years;
  - when the set is used in circumstances with higher dust, grease or moisture levels, for example in a kitchen, the recommended interval is 1 year.
- The maintenance inspection contains the following actions:
- execute the above mentioned "general repair instruction";
  - clean the power supply and deflection circuitry on the chassis;
  - clean the picture tube panel and the neck of the picture tube.

#### Warnings

1. In order to prevent damage to ICs and transistors, all high-voltage flashovers must be avoided. In order to prevent damage to the picture tube, the method shown in Fig. 3.1 should be used to discharge the picture tube. Use a high-voltage probe and a multimeter (position DC-V). Discharge until the meter reading is 0V (after approx. 30s).

#### ESD

2. All ICs and many other semiconductors are sensitive to electrostatic discharges (ESD). Careless handling during repair can drastically shorten the life. Make sure that during repair you are connected by a pulse band with resistance to the same potential as the earth of the unit. Keep components and tools also at this same potential.
3. Together with the deflection unit and any multipole unit, the flat square picture tubes used form an integrated unit. The deflection and the multipole units are set optimally at the factory. Adjustment of this unit during repair is therefore not recommended.

4. Be careful when taking measurements in the high-voltage section and on the picture tube.
5. Never replace modules or other components while the unit is switched on.
6. When making settings, use plastic rather than metal tools. This will prevent any short circuits and the danger of a circuit becoming unstable.

#### Notes

1. The direct voltages and oscillograms should be measured with regard to the tuner earth (⊥), or hot earth (⊥<sub>T</sub>) as this is called.
2. The direct voltages and oscillograms shown in the diagrams should be measured in the Service Default Mode (see chapter 8) with a colour bar signal and stereo sound (L3 KHz, R:1 KHz unless stated otherwise) and picture carrier at 475.25 MHz.
3. Where necessary, the oscillograms and direct voltages are measured with (T) and without aerial signal (X). Voltages in the power supply section are measured both for normal operation (D) and in standby (O). These values are indicated by means of the appropriate symbols.
4. The picture tube PWB has printed spark gaps. Each spark gap is connected between an electrode of the picture tube and the Aquadag coating.
5. The semiconductors indicated in the circuit diagram and in the parts lists are completely interchangeable per position with the semiconductors in the unit, irrespective of the type indication on these semiconductors.

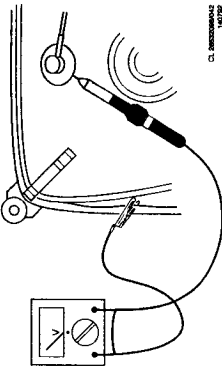

Figure 3.1

#### DOLBY SURROUND PRO • LOGIC

Manufactured under license from Dolby Laboratories Licensing Corporation.

DOLBY, the double-D symbol DD and PRO LOGIC are trademarks of Dolby Laboratories Licensing Corporation.

## 4. Mechanical instructions

The MD1.2E chassis has two different mechanical executions.

### 4.1 Styling with top control and side input/output (also applicable for MD1.1E Widescreen)

- Removing the rear cover**
1. First all screws on the rear cover have to be removed.
    - 4 Screws are located at each corner of the cabinet.
    - 2 Screws are located at the left and right bottom corners of the rear cover.
    - 4 Screws are fixed at the 4 corners of the I/O panel with the Euroconnectors and aerial input.
  2. The rear cover is now held in position by 6 clicks between the cabinet and the rear cover. There are 2 clicks at the left, 2 at the right and 2 at the top. After loosening all clicks (by releasing them with a screw-driver), the rear cover can be removed.
  3. The cover plate on the I/O panel with the Euro-connectors and aerial input can be removed in the following way: remove the screw in the middle, release the click connection at the bottom and lift the cover plate.

### Process position

- The process position provides easier access to the entire chassis.
1. Release the mains cord from its fixation brackets.
  2. Push back the clicks between bottom plate and rear cover and pull the cabinet at the same time backwards.

For some service positions cables may have to be removed from their cable clamps and channels. Afterwards, put the cables back in their original position.

### Service positions

#### Small Signal Panel (SSP) component side (Figure 4.1)

1. Push down the clicks of the SSP bracket (1) and shift the SSP to the left.
2. Pull up the SSP and tilt the SSP counter clockwise to a horizontal position (180° with Large Signal Panel (LSP)).
3. Put the SSP in the clicks (2) marked "Service" on the bottom plate.

When all cables on the SSP are disconnected, the SSP can also be removed from its bracket (Figure 4.2), providing better access to component and copper side.

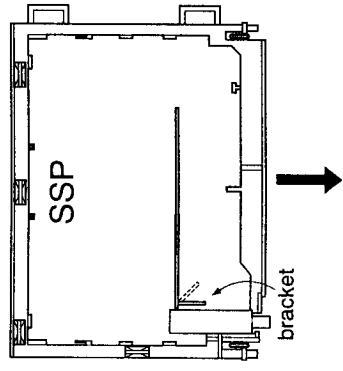

Figure 4.2

CLASS3202\_014.AI  
110696

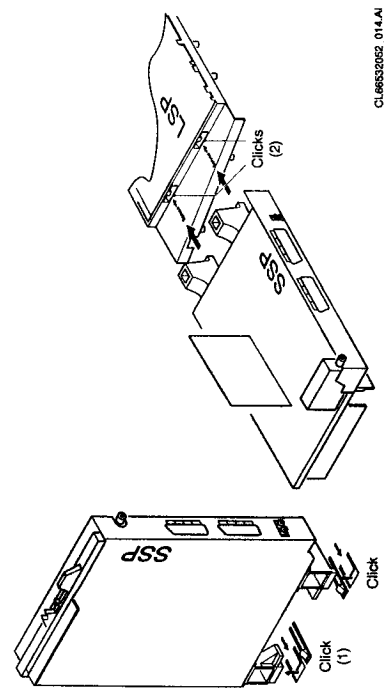

Figure 4.1

CLASS3202\_014.AI  
071096

For Service Manuals Contact  
**MAURITRON TECHNICAL SERVICES**  
 8 Cherry Tree Rd, Chinnor  
 Oxon OX9 4QY  
 Tel: 01844-351694 Fax: 01844-352554  
 Email: enquiries@mauritron.co.uk

### LSP component side (Figure 4.3)

1. Put the SSP in the horizontal service position as described above.
2. Remove screw (3) from the LOT bracket.
3. Remove the bracket by releasing click (4) and pulling the bracket upwards.
4. Release clicks (5) and (6).
5. Lift the LSP PWB out of its bracket (indicated by the arrow) and pull it a little back.

**Warning!** The heat sinks are not connected to ground.

- LSP copper side with table/workbench (Figure 4.4)**
1. Disconnect the cable to the degaussing coil (yellow connector L02 on LSP).
  2. If necessary, disconnect the cable on the left loudspeaker.
  3. Lift the LSP from its bracket as described above (LSP component side).
  4. Turn the LSP underneath the CRT panel (keep cable S15/L15 UNDER the audio module) as indicated by the arrow (7).
- The LSP now rests on the bottom plate, held in place by the cable clamp on the heat sink and the LOT bracket.

**Warning!** Be careful not to damage the CRT-panel or picture tube neck.  
 The heat sinks are not connected to ground.

**SSP and LSP copper side without table/workbench (Figure 4.5)**  
 For this service position MD1 cable extension kit (service code number 4822 320 11695) is required.

1. Break the service pin (marked M1 - see Figure 4.3) from its position at the right hand side of the bottom plate.
2. Disconnect the cable to the degaussing coil (yellow connector L02 on LSP) and the cable on the left loudspeaker.
3. Remove cables S10/L10, S11/L11 and S15/L15 from LSP to SSP and cable I28/L28 from Audio module to LSP.
4. Lift the LSP from its bracket as described earlier (LSP component side).
5. Put the LSP to the vertical position (Figure 4.5), copper side at the right hand, LOT above (8). For this position, special grooves are made in the bottom plate of the cabinet.
6. Fix the position of the LSP by putting the service pin between LSP (heat sink) and bottom plate (9). There are special holes in the heat sink and the bottom plate to put the service pin in.
7. Reconnect cable I28/L28.
8. Use the cables from the MD1 cable extension kit to reconnect connectors S10/L10, S11/L11 and S15/L15.

**Warning!** All cables should be reconnected correctly.

After use the service pin can be placed in the spare hole at the right hand side in the bottom plate.

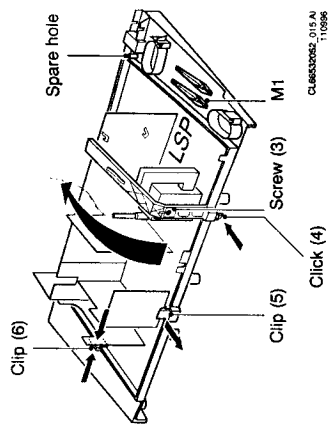

Figure 4.3

CLASS3202\_015.AI  
110696

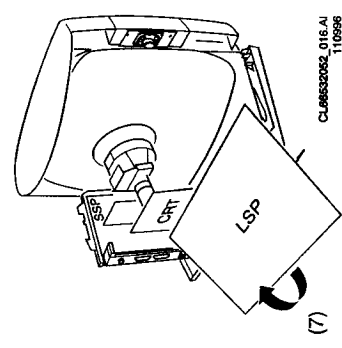

Figure 4.4

CLASS3202\_016.AI  
110696

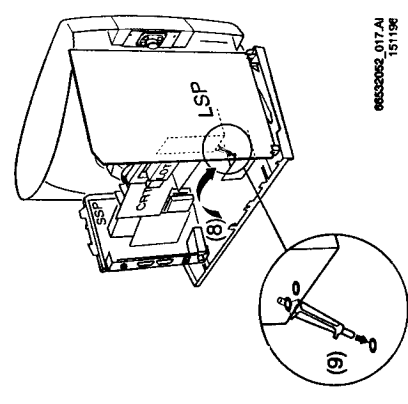

Figure 4.5

CLASS3202\_017.AI  
151196

Accessing the module with mains switch, LED and RCS receiver (Fig. 4.6)

1. Cut the tie rap of the degaussing coil at the left hand bottom side (10). Remove the degaussing coil in the left bottom corner from its fixation bracket (11) to get more space to handle the mains module.
2. Remove the red mains panel bracket by lifting the end and pulling it backwards (12).
3. To get more movement space, the left top of the cabinet can be pushed or pulled upwards (13).
4. The mains panel can now be removed.

Afterwards the degaussing coil should be refixed at position (10).

### 4.2 Styling with side control and side input/output (no top control)

**Removing the rear cover**

1. First all screws on the rear cover have to be removed.
  - 6 Screws are located at the corners of the cabinet.
  - 2 Screws are located at the left and right bottom of the rear cover.
  - 3 Screws are located just above, under and left of the cover plate of the I/O connections.

*For some service positions cables may have to be removed from their cable clamps and channels. Afterwards, put the cables back in their original position.*

**Process position**

The process position provides easier access to the entire chassis during the service positions.

1. The chassis can be lifted, pulled forward ( $\pm 5$ cm) and fixed in the bottom plate.
2. When the clicks between bottom plate rear cover are pushed back, the chassis and the bottom plate can be pulled backwards.

**Service positions**

**SSP copper and component side, module servicing (Figure 4.7)**

1. Release the click construction (14) between the SSP and LSP.
2. Lift the SSP a little and turn it to an angle of 135° (15) or 180° (16) from the LSP. This provides better access to the component side of the SSP and also allows for the removal of modules.

**Service position with table/workbench (Fig. 4.8)**

1. Disconnect the cable to the degaussing coil (yellow connector L02 on the LSP).
2. Lift the chassis from the bottom plate and pull it backwards (17).
3. Turn the entire chassis around the CRT-panel (18). The chassis rests on the SSP with the copper side of the LSP backwards.

**Warning!** *Be careful not to damage the CRT-panel or picture tube neck. The heat sinks are not connected to ground.*

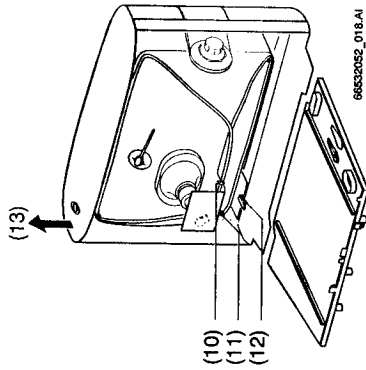

Figure 4.6

66632052\_018.AI  
25/0696

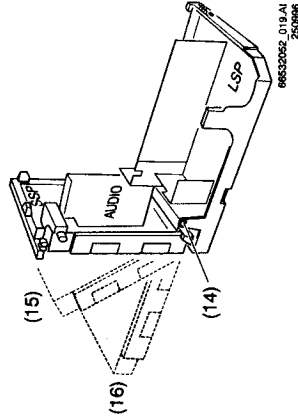

Figure 4.7

66632052\_019.AI  
25/0696

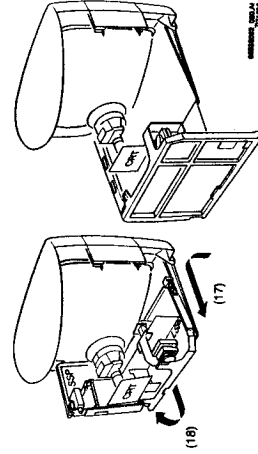

Figure 4.8

66632052\_020.AI  
25/0696

**Service position (LSP copper side) without table/workbench (Fig. 4.9)**

1. Disconnect the cable to the degaussing coil (yellow connector L02 on the LSP).
2. Lift the chassis from the bottom plate and turn it counter clockwise (19).
3. The SSP can be fixed with a screwdriver to the bottom plate (20). The copper side of the LSP can now be accessed.

**Warning!** *Be careful not to damage the CRT-panel or picture tube neck. The heat sinks are not connected to ground.*

**Small Signal Panel (Fig. 4.2)**

First, remove all cables connected to the Small Signal Panel. The SSP can be removed by sliding it out of the SSP bracket (in the direction of the arrow).

**Large Signal Panel (Fig. 4.10)**

After removing the screw (21), and pushing back the clips (22), the LSP can be lifted out the bracket as indicated by the arrow.

**Accessing the panel with mains switch, LED and RCS receiver**

The mains module is located in the middle of the set, below the picture tube.

1. Push the clicks between bottom plate and rear cover back and pull the chassis back as far as possible.
2. Release the click construction (14 - Fig. 4.7) between the SSP and LSP. Lift the SSP a little and turn it to an angle of 180° (16 - see Fig. 4.7) from the LSP. The mains panel can now be accessed when reaching over the SSP/LSP.
3. Remove the 2 screws left and right on the mains panel bracket.

The complete mains panel can now be removed by pulling it backwards

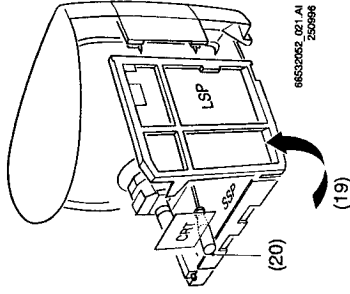

Figure 4.9

66632052\_021.AI  
25/0696

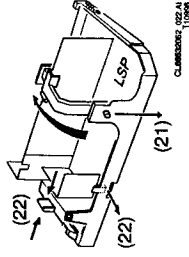
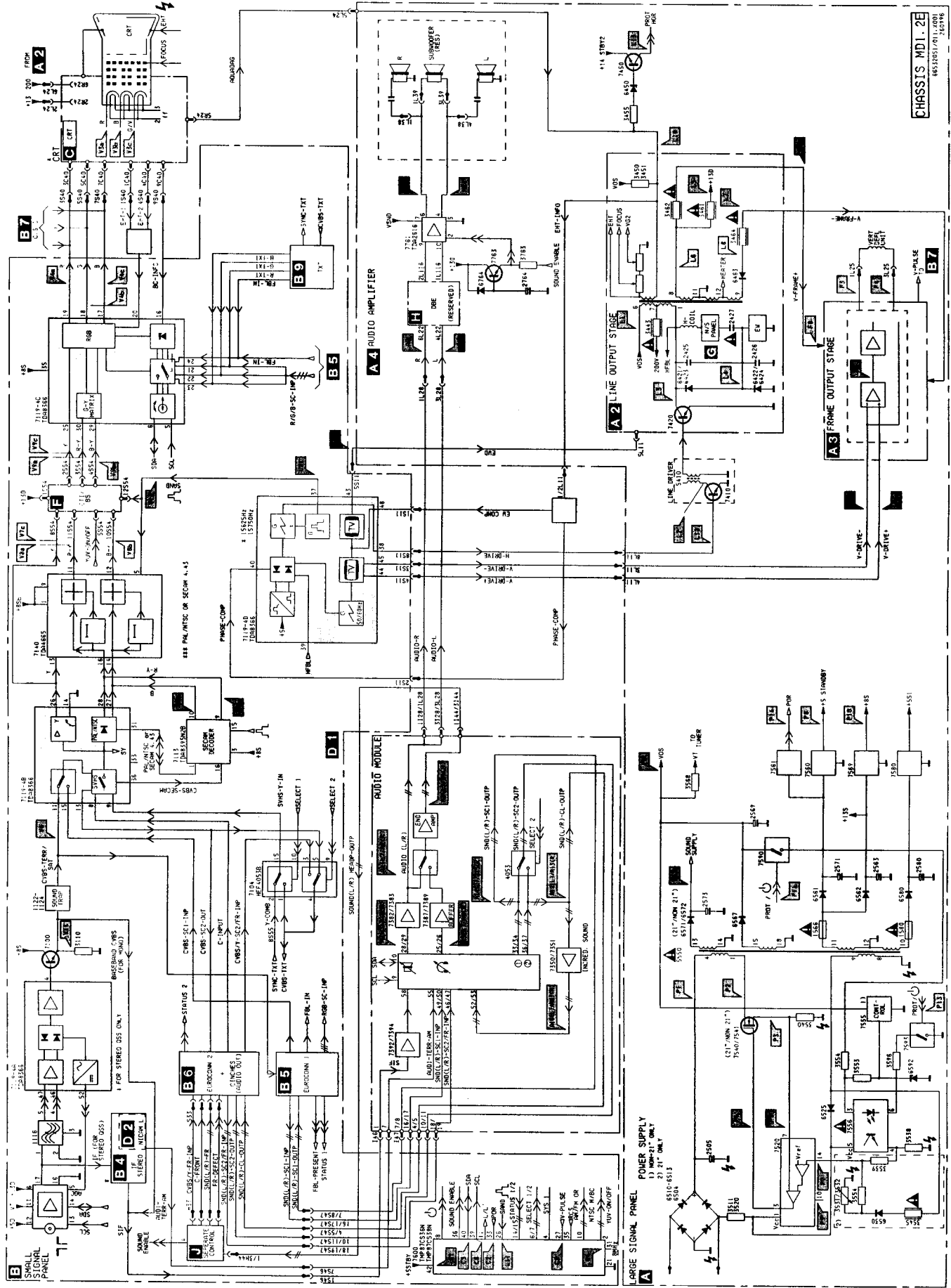

Figure 4.10

66632052\_022.AI  
1/0299

5. Block diagram / Blockschaltbild / Schéma-bloc 6



For Service Manuals Contact  
**MAURITRON TECHNICAL SERVICES**  
 8 Cherry Tree Rd, Chinnor  
 Oxon OX9 4QY  
 Tel: 01844-351694 Fax: 01844-352554  
 Email: enquiries@maurtron.co.uk

# Testpoint overview / Testpunkt Übersicht / Relevé des points de test

## Large signal panel / Groß-Signal Platine / Platine forts signaux

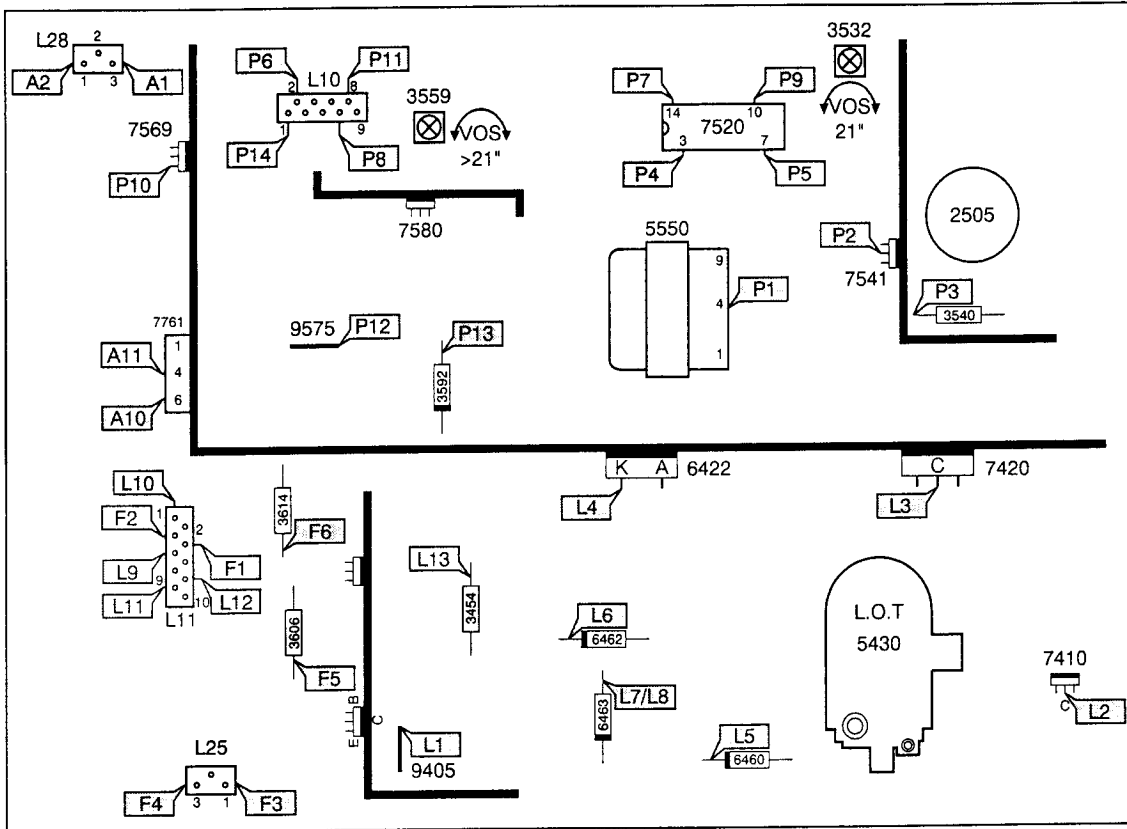

Small signal panel / Klein-Signal Platine / Platine petits signaux

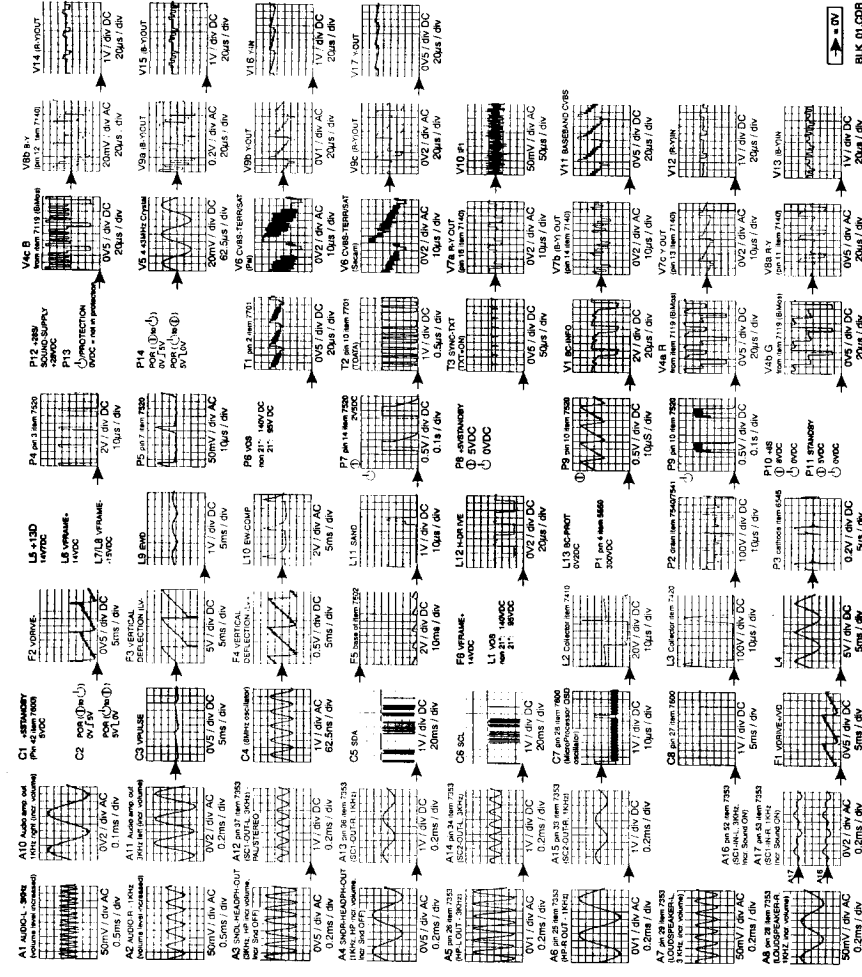
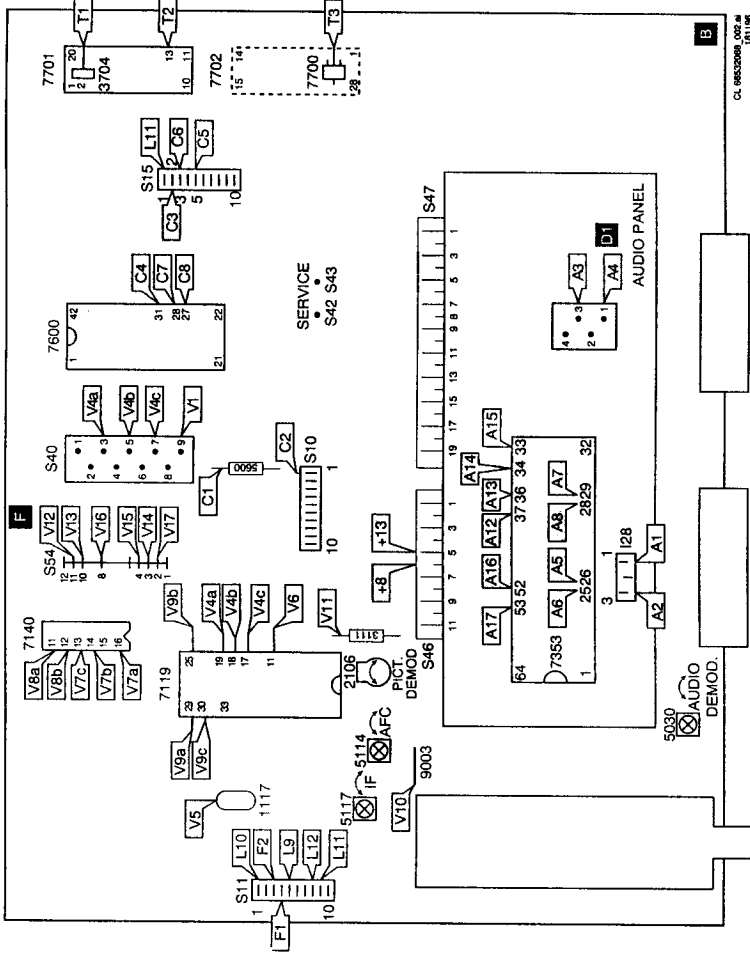

BLK 01.00R



CRT panel / CRT-Platine / Platine tube cathodique

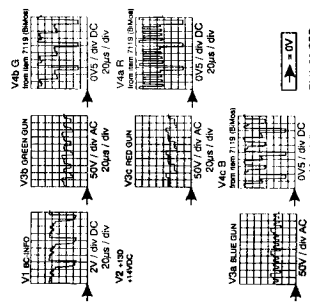
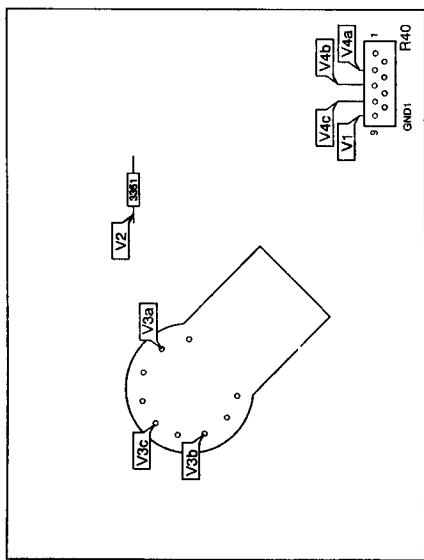

CTI/Black Stretch panel /  
CTI/Black Stretch Platine /  
Platine CTI/Black Stretch

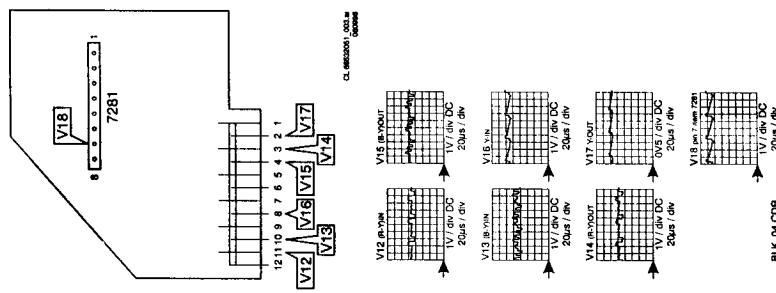

For Service Manuals Contact  
**MAURITRON TECHNICAL SERVICES**  
8 Cherry Tree Rd, Chinnor  
Oxon OX9 4QY  
Tel:- 01844-351694 Fax:- 01844-352554  
Email:- enquiries@mauritron.co.uk

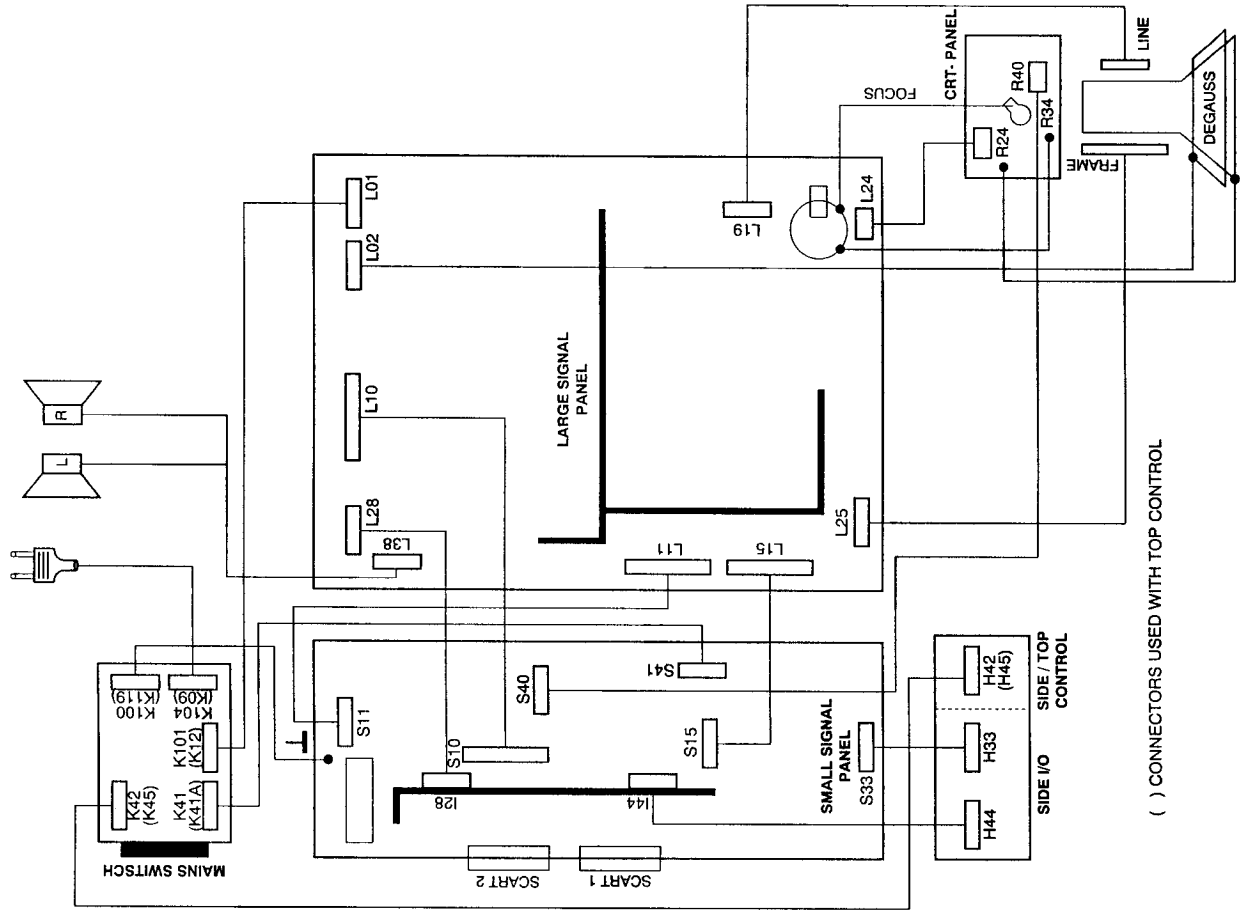

( ) CONNECTORS USED WITH TOP CONTROL

## 6. Service Modes, DST, Error messages, Protections, Faultfinding and Repair tips

In this chapter the following paragraphs are included:

- 6.1 Test points
- 6.2 Service Modes and Dealer Service Tool (DST)
- 6.3 Error codes and "blinking LED" procedure
- 6.4 Protections
- 6.5 Fault finding and repair tips

### 6.1 Test points

The MD1 chassis is equipped with test points in the service printing. These test points are referring to the functional blocks:

- \* A1-A2-A3, etc.: Test points for the audio processing circuitry
- \* C1-C2-C3, etc.: Test points for the control circuitry
- \* F1-F2-F3, etc.: Test points for the frame drive and frame output circuitry
- \* L1-L2-L3, etc.: Test points for the line drive and line output circuitry
- \* P1-P2-P3, etc.: Test points for the power supply
- \* T1-T2-T3, etc.: Test point for the teletext circuitry
- \* V1-V2-V3, etc.: Test points for the video processing circuitry

### 6.2 Service modes and Dealer Service Tool (DST)

For easy installation and diagnosis the dealer remote control RC7150 is introduced. The RC7150 can be used for all new TV sets, including all set of the MD1 chassis. The RC7150 is also called Dealer Service Tool or DST. The ordering number of the DST (RC7150) is 4822 218 21232.

#### 6.2.1 Installation features for the dealer

The dealer can use the RC7150 for programming the TV-set with presets, TV-settings, Dish settings.

10 Different program tables can be programmed into the DST via a GFL or MD2 TV-set (downloading from the GFL or MD2 to the DST; see GFL or MD2 service manuals) or by the DST-I (DST/PC interface; ordering code 4822 218 21277). For explanation of the installation features of the DST, the directions for use of the DST are recommended (For the MD1 chassis, download code 4 should be used).

#### 6.2.2 Diagnose features for the servicer

The MD1.2 sets can be put in the two service modes via the DST RC7150. These are the Service Alignment Mode (SAM) and the Service Default Mode (SDM). SDM can also be entered by short circuiting the "service" pins on the SSP.

##### 6.2.2.1 Service Default Mode (SDM)

Entering the SDM:

- By transmitting the "DEFAULT" command with the RC7150 Dealer Service Tool.
- By temporarily shorting pins S42 and S43 on the Small Signal Panel.

Exiting the SDM:

- Switch the set to stand-by (the error buffer is also cleared).

**Note:** *When the mains power is switched off while the set is in SDM, the set will enter to SDM immediately when the mains is switched on again.*

The SDM has the following pre-defined conditions for all microprocessor controlled tuning and linear functions:

- For recognition of the SDM "SER" is displayed at the top of the screen.
  - Tuning at 475.25 MHz (Secam on Multi-France sets (with Nicam L), PAL on other sets).
  - Volume level is set to 25% (of the maximum volume level). Other picture and sound settings are set to 50%.
  - Auto switch off disabled (normally the set is automatically switched off when no video signal (IDENT) was received for 15 minutes).
  - Sleep timer is disabled.
  - All other controls operate normally.
  - *When the microprocessor supports the "blinking LED" procedure (See 6.3) and an error code is present in the error buffer, the LED will blink the number of times, equal to the value of the last error code.*
- This function will also work when there is no sound or picture.**

##### 6.2.2.2 Service Alignment Mode (SAM)

Entering SAM:

- By transmitting the "ALIGN" command with the RC7150 Dealer Service Tool (this works both while the set is in normal operation mode or in the SDM).
- By pressing the "MENU" and "." key on the local keyboard simultaneously when the set is in SDM.

Exiting SAM:

- Switch the set to stand-by.

**Note:** *When the mains power is switched off while the set is in SAM, the set will enter SDM immediately when the mains is switched on again.*

In the SAM the following information is displayed on the screen:

- Software version (the software version of the microprocessor in the set is displayed. This software version identification corresponds with the software versions in the Software Survey as published in the Product Survey.
- Error code buffer (see paragraph 6.3).
- Options (see paragraph 8.4).
- Alignment and geometry information (see paragraph 8.2.1, 8.3.1 and 8.3.2).

- (1) Software version
- (2) Error buffer
- (3) Options
- (4) Alignments and geometry

M12XXx-x x	0	0	0	0	0	0	0	0	0
ER	0	0	0	0	0	0	0	0	0
EZ	N	N	N	N	N	N	N	N	N
UC	N	N	N	N	N	N	N	N	N
LL	N	N	N	N	N	N	N	N	N
NI	N	N	N	N	N	N	N	N	N
TI	N	N	N	N	N	N	N	N	N
HI	N	N	N	N	N	N	N	N	N
14	N	N	N	N	N	N	N	N	N

Figure 6.1 Screen of the Service Alignment Mode (SAM)

6.3 Error codes and "blinking LED" procedure

The error code buffer contains all errors detected since the last time the buffer was erased. The buffer is written from left to right.

- The last error detected (actual) is the error at the left side
- The error buffer will be reset in the following cases:
  1. exiting the SAM with the 'standby' command on the remote control
  2. transmitting the commands 'DIAGNOSE 9 9 OK' with the DST
- By leaving the SAM with the mains switch, the error buffer is not reset.

Examples:  
 ERROR: 0 0 0 0 0 0: No error code detected  
 ERROR: 3 0 0 0 0 0: Error code 3 is the last and only detected error  
 ERROR: 5 3 0 0 0 0: Error code 3 first and error code 5 last detected

The contents of the error buffer can also be made visible through the "blinking LED" procedure. This is especially useful when there is no picture. There are two methods:

1. When the SDM is entered, the LED will blink the number of times, equal to the value of the last error code. The LED will stay off briefly and blink again the number of times, equal to the value to the last error code
2. With the DST all error codes in the error buffer can be made visible. While in SDM, transmit the command: "DIAGNOSE x OK" where x is the position in the error buffer to be made visible (actual) error to 7 (the first error)

The LED will operate in the same way as in point 1, but now for the error code on position x.

Example:  
 Error code position 1 2 3 4 5 6 7  
 Error buffer 2 4 1 0 0 0 0

- after entering SDM blink (2x) - pause - blink (2x)
- after transmitting "DIAGNOSE 2 OK" with the DST blink (4x) - pause - blink (4x)
- after transmitting "DIAGNOSE 3 OK" with the DST blink - pause - blink
- after transmitting "DIAGNOSE 4 OK" with the DST nothing happens

Note!  
 Note that it may take up to 7 seconds before the set responds to a DIAGNOSE command. Interruption of the blinking sequence may lead to incorrect results.

Important!  
 Not all software versions of the MD1.2E chassis support the blinking LED procedure and the DIAGNOSE 99 command. Software versions NOT supporting the blinking LED procedure are M12BAx-x.x and M12COx-3.x.

Error code	Error description	Blinking LED	Possible defective components
0	No error detected	—	—
1	BIMOS (TDA8366) error	1x	IC7119 (SSP)
2	MSP3400/3410 error	2x	IC7353 (SSP)
3	I <sup>2</sup> C bus error	3x	All I <sup>2</sup> C-related components
4	Wrong EEPROM	4x	IC7685 (SSP)
5	EEPROM defective	5x	IC7685 (SSP)
6	Tuner error	6x	U1000 (SSP)
7	TXT error	7x	IC7702 (SSP)
8	Histogram Proc. error	8x	IC7210 (reserved)
9	16:9 processor error	9x	IC7440 (16:9 module)
10	WSSB module error	10x	IC7540 (WSSB module)
11	Dolby processor error	11x	IC7600 (Audio module)

Table 6.1 Error code list

6.4 Protections

6.4.1 In the MD 1.2E the following protections are possible:

- Protections generated by the power supply:
  - Overload protection → Hick up mode
  - Underload → Hick up mode
  - Over voltage → Hick up mode
  - Under voltage → Hick up mode

- Deflection:
  - Horizontal Protection → Supply to standby
  - EW-Protection → Supply to standby
  - Vertical Protection → BIMOS standby mode

Software protection

- BIMOS IC7119 defective → (Error code 1)

Set can be switched between standby and ON, but there is no picture, no OSD, sound is only noise.

- SDA or SCL shorted → (Error code 3)

Set is switched to standby via standby line, set tries to restart.

- No +5Db or +8Sc at µC → Set is switched to standby via standby line, set tries to restart.

6.4.2 Power supply protections

The power supply will go to a very good audible hick-up mode in the following situations:

- Overload protection
- Under load
- Over voltage
- Under voltage

In hick-up mode  
 Pin 1 of IC7520 starts up from the start circuit for approximately 2 seconds, immediately after that the protection is activated. This cycle is constantly repeated in hick-up mode. When the set is in hick-up mode a short squeak is audible every 2 seconds.

6.4.3 Horizontal-protection

When the beam current becomes too high for a long period the voltage across C2450 will drop. D6450 will start conducting and as soon as the voltage drop across R9456 is 0V7, TS7450 will conduct, making PROT high. Via the hold-circuitry of the power supply, the set will stay in the protection mode (standby) and can only be reset by switching the set off and on via the mains switch. If the fault is still present, the set will switch to standby (protection mode) again.

6.4.4 EW-protection (not for 21" sets)

The East/West protection switches the power supply to standby via the signal line STANDBY-SUPPLY PROTECTION. Via the hold-circuitry of the power supply, the set will stay in the protection mode (standby) and can only be reset by switching the set off and on via the mains switch. If the fault is still present, the set will switch to standby (protection mode) again.

The East/West protection detects when the current through the East/West power output stage with TS7480 is too high

Note:  
 A current through the East/West stage (I<sub>ha</sub>) is too high can be caused by a defective part in the line-deflection circuitry!

The current through the East/West stage is measured on the LSP via 2 precision resistors (R3483 and R3484). In case of a line problem, the east/west-current becomes too high and the voltage across resistors R3483 and R3484 rises. When the voltage level exceeds 0.6V, D6480 starts to conduct and STANDBY-SUPPLY PROTECTION becomes HIGH. When the voltage across C2480 is very high (e.g. when a line problem is already present when the set is switched on with the mains switch), D6481 and D6482 conduct and EW-PROTECTION is activated very fast.

The East/West protection becomes active in the following cases:

- Bad contacts of horizontal deflection circuit:
    - bad contacts of horizontal deflection coil
    - bad contacts of linearity corrector coil L5421
    - bad contacts of S-corrector capacitor C2427
  - Bad contacts of flyback capacitor C2425.
  - Shorted flyback diode D6421 or D6423.
  - Shorted S-corrector capacitor C2427
  - Bad solder contacts in the line output stage.
- When EW-protection has been active, the line output transistor 7420 may also be defective.

6.4.5 Vertical-protection

The vertical output stage creates VERTICAL-PROTECTION pulses at every flyback pulse when it is functioning correctly. These pulses are sensed by the BIMOS IC7119-4D on pin 37. When the pulse train is interrupted, the BIMOS will switch to BIMOS STANDBY mode. In the BIMOS STANDBY mode, the BIMOS switches off the VDRIVE+ and VDRIVE- while the RGB outputs are blanked. Circuit breaker 1463 may be open. Probably, the line output stage will not work and the power supply will switch to hick-up mode (under voltage protection).

6.4.5 Software protection

The software protection is managed by the microprocessor. It continuously verifies the presence of the +5 and +8 supply voltages on pin 34 and the activity of the IC bus. When the protection becomes active, the software will switch the power supply on and off continuously via the STANDBY line. In this situation the power supply produces a squeaking sound.

### iC protection

The iC bus is controlled at each iC-command. Therefore every iC command has a defined start/stop condition. When the defined start/stop condition is repeatedly incorrect, error 3 is placed in the error buffer and the set switches to software protection.

iC-protection is generated in the following situations:

- SDA shorted to earth
  - SCL shorted to earth
  - SDA and SCL shorted
- When SCL or SDA is shorted, the set tries to restart and the LED lights in a clearly recognisable pattern.

- SDA/SCL shorted when the set is switched ON with the mains switch:
- LED is 8 seconds RED, 8 seconds GREEN, flashes RED, 8 seconds GREEN, flashes RED, 8 seconds GREEN, flashes RED, etcetera.
- SDA/SCL shorted during operation
- LED is 8 seconds GREEN, flashes RED, 8 seconds GREEN, flashes RED, etcetera.

- +5Db and +8Sc protection of the microprocessor
- +5Db and +8Sc are the main supply voltages of the entire small signal processing of the set. At pin 34 the microprocessor senses whether the supply voltages +5Sdb or +8Sc coming from the power supply are present. When one or both the supply voltages are missing, the set switches to software protection.

### 6.5 Fault finding and repair tips

Note that for 21\* sets, voltages and wave forms may differ.

#### 6.5.1 General

##### LED indication after start-up procedure is completed

- No LED
- Set is switched OFF, supply problem or microprocessor problem.
- LED continuously
- Set is in standby, control part defective, standby mode defective.
- LED blinking
- Set in SDM, transmitting error buffer.

##### Audible checks

- Demagnetisation audible: mains voltage is present at LSP.
- EHT audible: supply is operational (line output stage only works in case VOS (+140V for 25 & 29\*, +95V for 21\*) is present.
- Hick-up sound power supply audible: power supply is shorted. Check the LOT (item 5430) and the line output transistor TS7420.

#### 6.5.2 Fault finding in the power supply

In case of a power supply problem, the power supply can be simplified to a stand alone power supply at low voltages (low risk) as follows:

##### Control part of the power supply

1. Disconnect the SSP (as a result the line will not function any more and therefore will no longer be a load of the power supply) or disconnect the line by removing jumper 9400 and R3400 (if present) on the LSP.
2. Connect an external DC power supply between supply pin 1 (C7520 (via a diode - e.g. BYD33D - with cathode to supply pin 1 (C7520) and hot earth (e.g. earth of the big smoothing capacitor C2505).
3. Connect an oscilloscope to test point P4 at pin 3 (C7520).
4. Turn up the external DC supply voltage slowly to 17V DC.

**Remark:** The IC starts at a supply voltage of 14V DC, after that the supply voltage can drop to approx. 9V DC. At approximately 18V DC, over voltage protection becomes active, resulting in a supply voltage drop below 7V DC before a new start-up is performed by turning up the supply voltage above 14V DC.

5. The correct (measured) situation is displayed in . Other results indicate a defect in the power supply control part (C7520 or peripheral components at pins 10 or 11).

Figure 6.2:

5V/div; 50µS/div  
→ 40kHz pulse

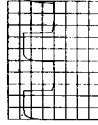

##### Energy transfer of the power supply (only if control part is OK)

6. Apply action 1, 2 and 4 as described earlier.
7. Connect a lamp of 230V/100W across the VOS output capacitor, C2569.
8. Connect a 1kΩ resistor between the +5STANDBY (connector 7L10) and the STANDBY line (connector 8L10) to switch the power supply to normal operation.
9. Connect the mains connector to a VARIAC but leave it at 0.
10. Connect a voltmeter across C2569 and an oscilloscope between the drain of TS7541 (25 & 29\*) or TS7540 (21\*) and hot earth.
11. Slowly increase the mains input voltage by the VARIAC (in this way further damage to the power supply can be avoided).

The wave forms for the following mains voltage are given:

**Mains in voltage**  
 10V AC: 20kHz and VOS 7V5  
 20V AC: 40kHz and VOS 30V  
 40V AC: 40kHz and VOS 80V  
 65V AC: 40kHz and VOS 140V  
 > 65V AC: Stable situation, so 40kHz and 140V or the voltage will exceed 140V (95V with 21\*)

Figure 6.3:

Mains in 10V AC  
 10V/div; 10µS/div



Figure 6.4:

Mains in 20V AC  
 20V/div; 50µS/div  
 → 40kHz pulse  
 → VOS 30V

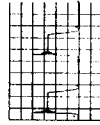

Figure 6.5:

Mains in 40V AC  
 50V/div; 50µS/div  
 → 40kHz pulse  
 → VOS 80V



Figure 6.6:

Mains in 65V AC  
 50V/div; 50µS/div  
 → 40kHz pulse  
 → VOS 140V



#### 6.5.3 Fault finding of the horizontal circuitry

When the horizontal circuitry itself is defective, it can be simplified to a stand alone "switched mode supply" at low voltages (low risk) as follows:

1. Disconnect the set from mains.
2. Disconnect the SSP by removing all cables to the SSP.
3. Connect an external 50V DC (or 40V DC) supply with current measurement possibility across C2400.
4. Replace the HDRIVE by an external LF generator (TTL level (between 0 and 5V), duty cycle 50%) with a 16 kHz pulse at the base of TS7410 (near LOT at the side of the PCB).
5. Connect an oscilloscope to test point L1 (collector of line output transistor 7420).

##### Possibilities:

1. Figure 6.7:  
 L3; test point at collector line output transistor (7420)  
 50V/div; 10µS/div  
 Current from external DC supply approx. 100mA

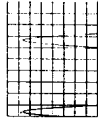

**Observation:** normal 16kHz pulses and 100mA supply current

Correct horizontal circuitry  
 Note that the amplitude of the signal strongly depends on the frequency of the generator.

Figure 6.8:

2. L3; test point at collector line output transistor (7420)  
 50V/div; 10µS/div

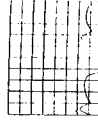

##### Line deflection open:

Current from external DC supply is approximately 100mA.

**Observation:** small pulse followed by wide pulse and 100mA supply current

**Causes:** horizontal deflection coil open  
 linearity coil L5421 open  
 S-correction C2427 open

Figure 6.9:

3. L3; test point at collector line output transistor (7420)  
 50V/div; 10µS/div  
 Current from external DC supply approx 500mA !!



**Observation:** fast oscillations and 500mA supply current

**Cause:** horizontal deflection shorted (e.g. line deflection coil shorted)

When the line deflection is not completely shorted but only a number of windings are shorted, the wave form does not show the oscillation and the current of the external DC supply is approximately 200mA.

Figure 6.10:

4. L3; test point at collector line output transistor (7420)  
 100V/div; 10µS/div

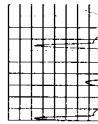

Current from external DC supply is approximately 150mA

**Observation:** flyback time is shorter, one extra pulse in between, 150mA supply current

**Cause:** flyback capacitor C2425 open

Figure 6.11:

5. L3; test point at collector line output transistor (7420)  
 100V/div; 10µS/div

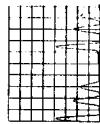

Current from external DC supply > 1A

**Observation:** 2 pulses per cycle extra and supply current from more than 1A

**Cause:** short-circuit in picture tube (e.g. EHT to Aquadag)

## Service Modes, DST, Error messages,

### 6.5.4 Fault finding "no picture, no protection" (problem in the video controller IC part TDA8366-4C)

When there is no picture and no protection, it is most likely that there is a problem with the BC\_INFO caused by the TDA8366, the RGB amplifiers or the picture tube.

For measuring, connect a video generator (e.g. PM5518) at the aerial input with a white pattern to the tuner. Trigger the oscilloscope field frequent. A stable picture is obtained if triggered with VDRIVE+ at pin 4 S11.

#### Normal start up procedure

1. First phase of start up: 4 white measuring lines (lines 15, 16, 17, 18) and the main picture is muted (wave forms are better visible if the picture tube is cold);

Figure 6.12:

Red (pin 8 of connector R43 on the CRT panel) and green gun (pin 6) 100V/div DC; 100µs/div

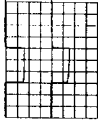

The total beam current is measured and fed back to pin 16 TDA8366 (IC7119)

The TDA8366 checks the voltage at pin 16 of the TDA8366 during these lines

- < 4.5V : set remains in this phase
- ≥ 4.5V : set continues with start up phase 2

2. Second phase of start up: each beam is separately measured and the main picture is still muted. Line 15 is Red, line 16 is Green and line 17 is Blue. BC\_INFO is measured.

- differences between the lines (guns) are compensated
- when the differences are minimal the set continues with phase 3, otherwise it remains in phase 2

Figure 6.13:

Red (lower line) (pin 8 of connector R43 on the CRT panel) and green (upper line) gun (pin 6) 50V/div AC; 100µs/div



3. After start up the picture is present and differences in cut-off points of the R, the G and the B gun are compensated continuously.

#### Repair procedure

##### Typical situation: no picture and no error codes

- Switch the set on.
- In a 4:3 set, press "picture size" to switch the set to "16:9 compressed" mode.
- In a 16:9 set, shift down the picture with the cursor keys.

## Protections, Faultfinding and Repair tips

### Notes

- The start up phase of the set can be identified:
1. A bright white horizontal line at the top; the rest of the picture is dark (set hangs in first phase of start up procedure)  
Oscilloscope picture of the voltage over the guns looks like figure 6.12.

TDA8366 (IC7119), picture tube and RGB amplifiers are OK

There should be 4.5V at pin 16 TDA8366.

**Possible problem:** if there is no 4.5V present at pin 16 of TDA8366, there is a defect (in one or more of the components) in the BC\_INFO feedback loop.

2. Small horizontal red, green and blue lines at the top; the rest of the picture is dark (set hangs in second phase of start up procedure)  
TDA8366 is OK

**Possible problem:** one or more of the guns of the picture tube are bad  
Measure at pin 16 TDA8366 which feedback line(s) (the R or G or B line) is/are smaller; the corresponding amplifier(s) or gun(s) is/are faulty.

3. No lines visible (picture dark)

Measure pin 16 TDA8366; possible measurements:

- 0V : Check TDA8366 (sandcastle and the supply voltage)
- 5V : Check RGB amplifiers  
Short pin 16 TDA8366 to ground, now there will be measuring lines (at continuously 5V, phase 1 and 2, is bypassed)  
there is a measuring line, so the TDA8366 is OK
- Pulses : Measure on cathode on the CRT panel if the measuring lines are present:  
Yes → BC\_INFO circuit is open or no HEATER voltage  
No → RGB amplifier problem

For Service Manuals Contact  
MAURITRON TECHNICAL SERVICES  
8 Cherry Tree Rd, Chinnor  
Oxon OX9 4QY  
Tel: 01844-351694 Fax: 01844-352554  
Email: enquiries@mauritron.co.uk



# Power supply 21" / Speisespannung 21" /

## A1

# 21" POWER SUPPLY

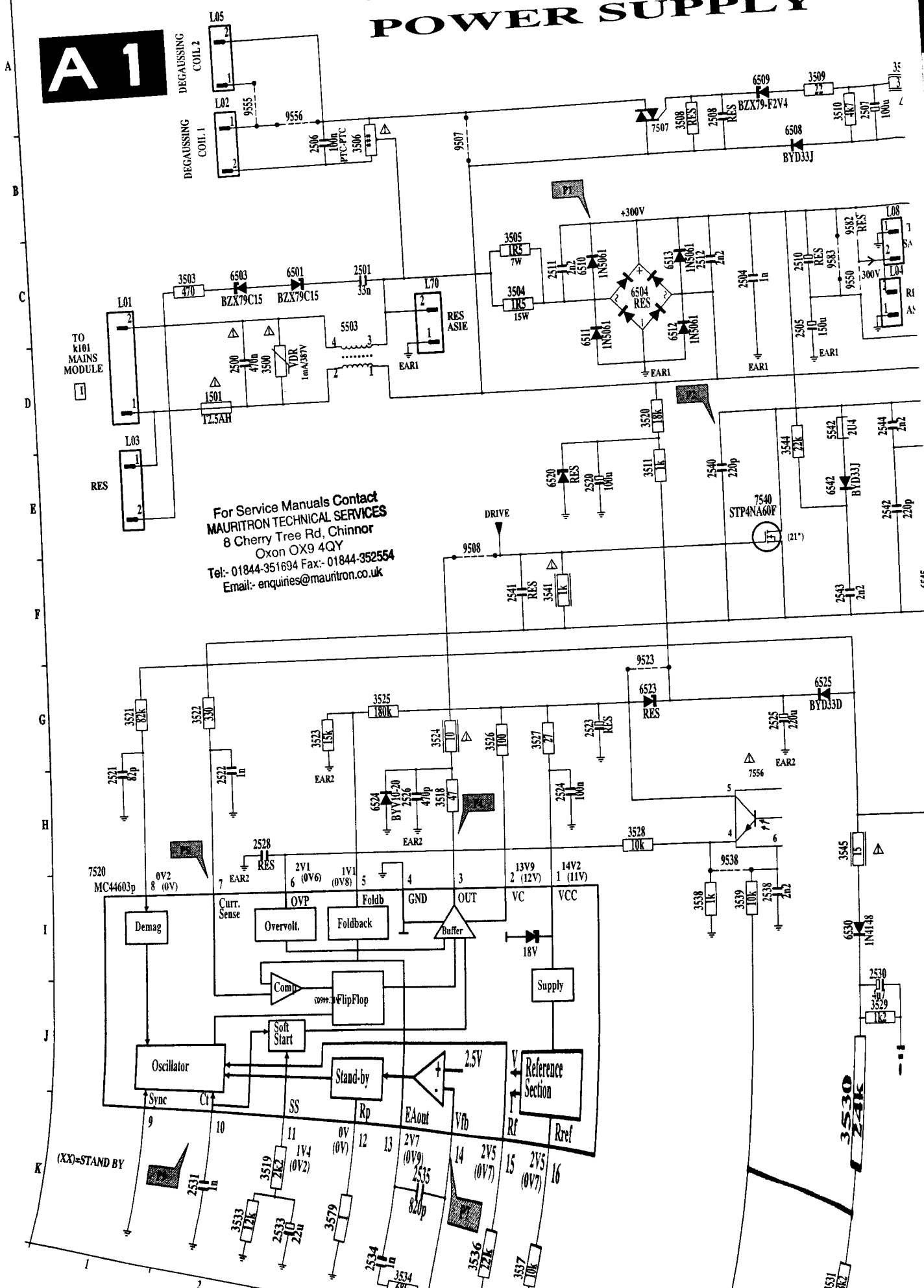

For Service Manuals Contact  
**MAURITRON TECHNICAL SERVICES**  
 8 Cherry Tree Rd, Chinnor  
 Oxon OX9 4QY  
 Tel: 01844-351694 Fax: 01844-352554  
 Email: enquiries@mauritron.co.uk

(XX)=STAND BY

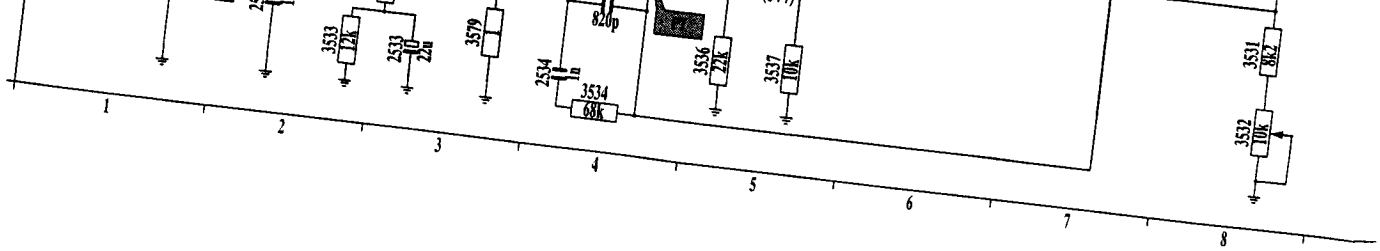

[Redacted text]

[Redacted text]

[Redacted text]

[Redacted text]

[Redacted text]

[Redacted text]



Chassis MD1.2E

13

Alimentation 21"

# R SUPPLY

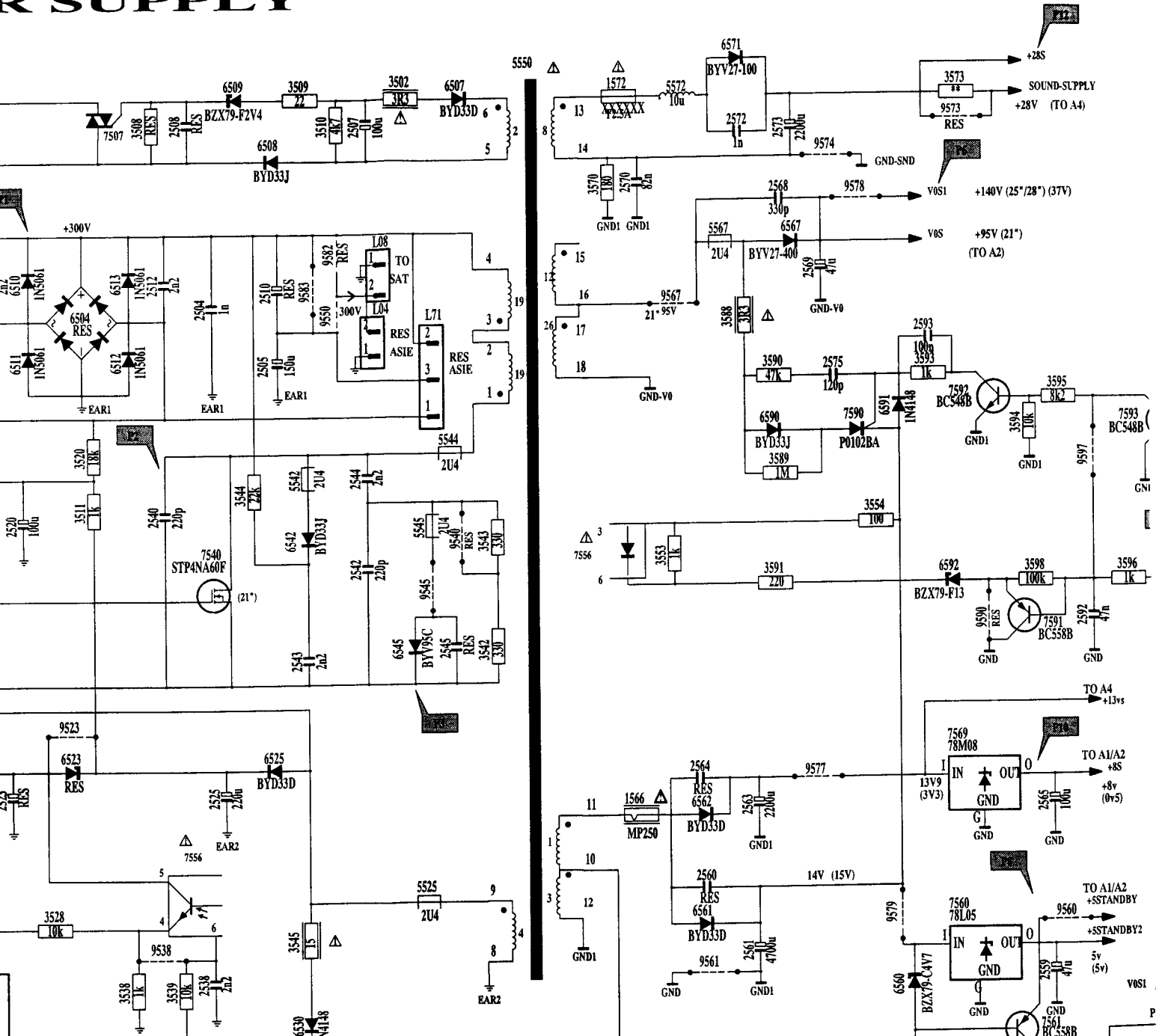

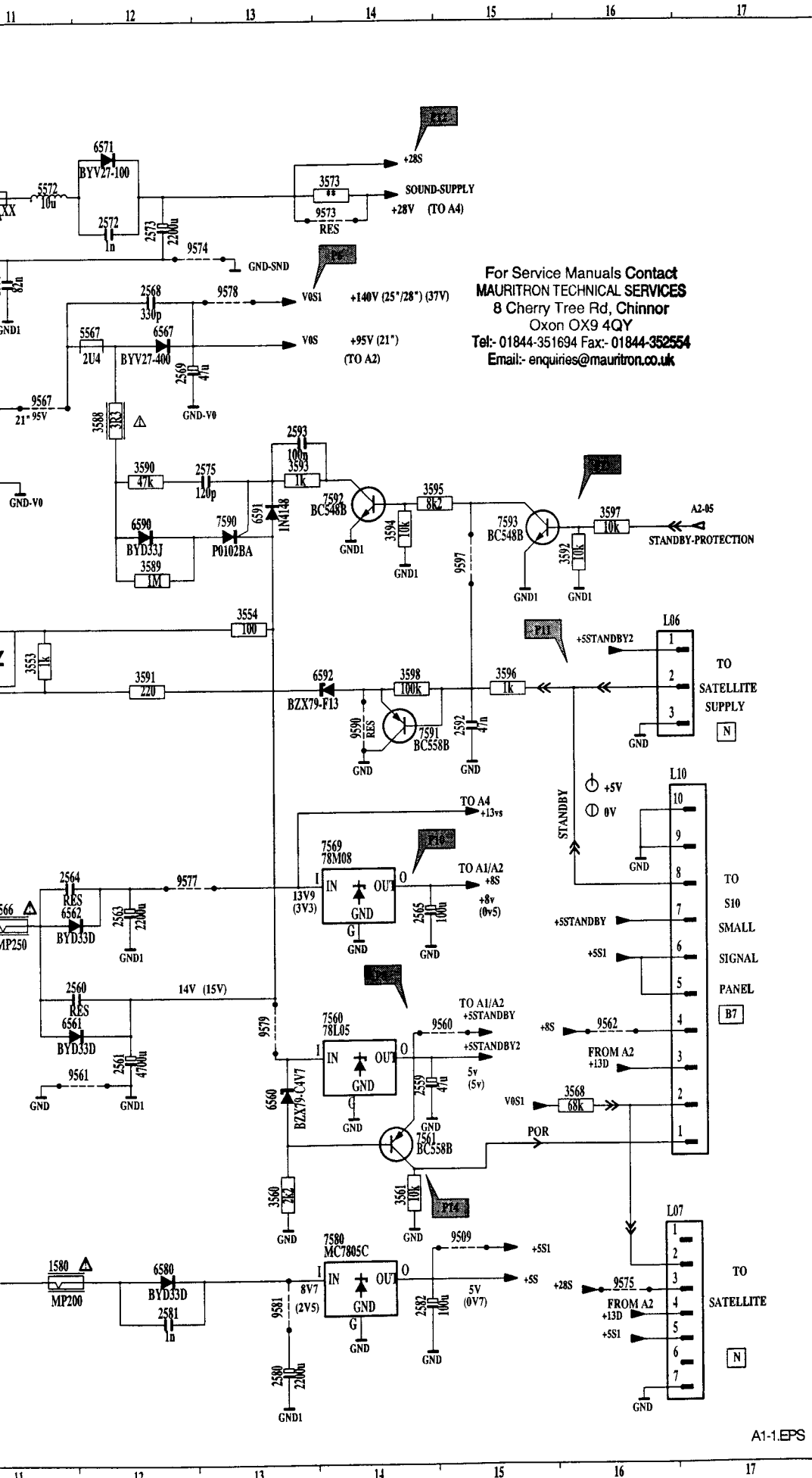

For Service Manuals Contact  
**MAURITRON TECHNICAL SERVICES**  
 8 Cherry Tree Rd, Chinnor  
 Oxon OX9 4QY  
 Tel: 01844-351694 Fax: 01844-352554  
 Email: enquiries@mauriton.co.uk

A  
B  
C  
D  
E  
F  
G  
H  
I  
J  
K

651  
652  
653  
654  
655  
656  
657  
658  
659  
660  
661  
662  
663  
664  
665  
666  
667  
668  
669  
670  
671  
672  
673  
674  
675  
676  
677  
678  
679  
680  
681  
682  
683  
684  
685  
686  
687  
688  
689  
690  
691  
692  
693  
694  
695  
696  
697  
698  
699  
700  
701  
702  
703  
704  
705  
706  
707  
708  
709  
710  
711  
712  
713  
714  
715  
716  
717  
718  
719  
720  
721  
722  
723  
724  
725  
726  
727  
728  
729  
730  
731  
732  
733  
734  
735  
736  
737  
738  
739  
740  
741  
742  
743  
744  
745  
746  
747  
748  
749  
750  
751  
752  
753  
754  
755  
756  
757  
758  
759  
760  
761  
762  
763  
764  
765  
766  
767  
768  
769  
770  
771  
772  
773  
774  
775  
776  
777  
778  
779  
780  
781  
782  
783  
784  
785  
786  
787  
788  
789  
790  
791  
792  
793  
794  
795  
796  
797  
798  
799  
800  
801  
802  
803  
804  
805  
806  
807  
808  
809  
810  
811  
812  
813  
814  
815  
816  
817  
818  
819  
820  
821  
822  
823  
824  
825  
826  
827  
828  
829  
830  
831  
832  
833  
834  
835  
836  
837  
838  
839  
840  
841  
842  
843  
844  
845  
846  
847  
848  
849  
850  
851  
852  
853  
854  
855  
856  
857  
858  
859  
860  
861  
862  
863  
864  
865  
866  
867  
868  
869  
870  
871  
872  
873  
874  
875  
876  
877  
878  
879  
880  
881  
882  
883  
884  
885  
886  
887  
888  
889  
890  
891  
892  
893  
894  
895  
896  
897  
898  
899  
900  
901  
902  
903  
904  
905  
906  
907  
908  
909  
910  
911  
912  
913  
914  
915  
916  
917  
918  
919  
920  
921  
922  
923  
924  
925  
926  
927  
928  
929  
930  
931  
932  
933  
934  
935  
936  
937  
938  
939  
940  
941  
942  
943  
944  
945  
946  
947  
948  
949  
950  
951  
952  
953  
954  
955  
956  
957  
958  
959  
960  
961  
962  
963  
964  
965  
966  
967  
968  
969  
970  
971  
972  
973  
974  
975  
976  
977  
978  
979  
980  
981  
982  
983  
984  
985  
986  
987  
988  
989  
990  
991  
992  
993  
994  
995  
996  
997  
998  
999  
1000

- P1 pin 4 item 5550  
300VDC
- P2 tran item 7540/754
- 100V / div DC  
10µs / div
- P3 cathode item 6545
- 0.2V / div DC  
5µs / div
- P4 pin 3 item 7520
- 2V / div DC  
10µs / div
- P5 pin 7 item 7520
- 50mV / div AC  
10µs / div
- P6 v0S  
non 21: 140V DC  
21: 95V DC
- P7 pin 14 item 7520
- 2VSDC
- 0.5V / div DC  
0.1s / div
- P8 +5VSTANDBY  
⊕ 5VDC  
⊖ 0VDC
- P9 pin 10 item 7520
- 0.5V / div DC  
10µS / div
- P10 +8S  
⊕ 8VDC  
⊖ 0VDC
- P11 STANDBY  
⊕ 5VDC  
⊖ 0VDC
- P12 +28S/  
SOUND-SUPPLY  
+28VDC
- P13  
⊕ PROTECTION  
0VDC = not in protection
- P14  
POR (⊕ to ⊕)  
0V / 5V  
POR (⊕ to ⊕)  
5V / 0V

OSC A1.CDR

SECTION

TO  
ELLITE  
PLY  
N

TO  
S10  
SMALL  
SIGNAL  
PANEL  
B7

TO  
TELLITE  
N

A1-1.EPS

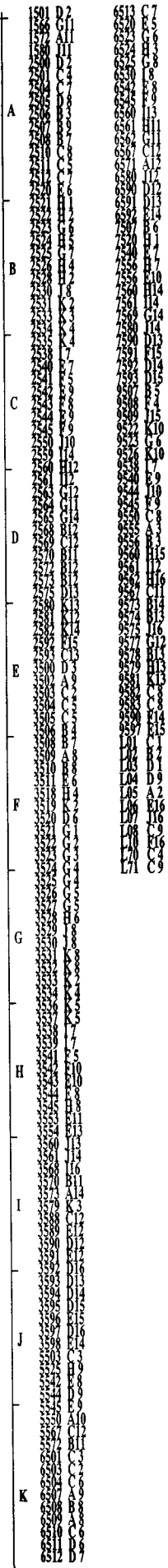

P1 pin 4 item 5550  
300VDC

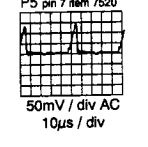
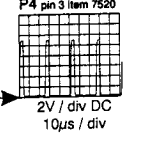
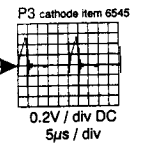
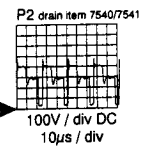

P6 VDS  
non 21: 140V DC  
21: 95V DC

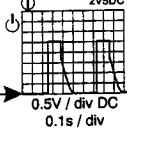

P8 +5VSTANDBY  
① 5VDC  
⓪ 0VDC

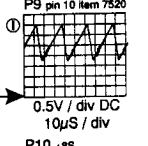

P10 +5S  
① 5VDC  
⓪ 0VDC

P11 STANDBY  
① 5VDC  
⓪ 0VDC

P12 +28S/  
SOUND-SUPPLY  
+28VDC

P13  
⓪ PROTECTION  
0VDC = not in protection

P14  
POR (⓪ to ⓪)  
0V / 5V  
POR (⓪ to ⓪)  
5V / 0V

OSC A1.CDR

For Service Manuals Contact  
**MAURITRON TECHNICAL SERVICES**  
 8 Cherry Tree Rd, Chinnor  
 Oxon OX9 4QY  
 Tel:- 01844-351694 Fax:- 01844-352554  
 Email:- enquiries@mauritron.co.uk

# Large signal panel / Groß-Signal Platine / Platine forts signaux

L01 J10	2545 H6	3503 K9	3756 A9	7540 H8	9577 C8
L02 I10	2550 F6	3504 J7	3757 B9	7541 H7	9578 C6
L03 J10	2554 E9	3505 K7	3758 B9	7555 E10	9579 D8
L04 K6	2555 E10	3506 H9	3759 B9	7560 C9	9581 D8
L05 H10	2557 E10	3507 I9	3760 A9	7561 D10	9582 I6
L06 B10	2559 D9	3508 I9	3761 B6	7569 B9	9583 I8
L07 C10	2560 D8	3509 H9	3762 B8	7580 D9	9590 D9
L08 K7	2561 C7	3510 G8	3763 B6	7590 D7	9601 B2
L10 D10	2563 D8	3511 H8	3764 A7	7591 D9	9602 A5
L11 A5	2564 D8	3512 H9	3765 B8	7592 D6	9603 A4
L13 A3	2565 B10	3518 F9	3766 B8	7593 C6	9604 B3
L14 A5	2568 E6	3519 G10	3767 B8	7600 C2	9605 B3
L15 A3	2569 F6	3520 I8	5400 C3	7601 C4	9606 B4
L17 I4	2570 E7	3521 G9	5401 D2	7602 B2	9607 B4
L19 J4	2572 D8	3522 H8	5410 J4	7603 B4	9608 A5
L22 C7	2573 D7	3523 F9	5411 K5	7604 B3	9609 B4
L24 J1	2575 D6	3524 H8	5421 G4	7605 B2	9611 B4
L25 B1	2580 E9	3525 G9	5424 E5	7606 B4	9615 A3
L28 A10	2581 D8	3526 F9	5430 H3	7760 A9	9620 A1
L38 A8	2582 D9	3527 F9	5460 G2	7761 B6	9621 B1
L39 A8	2592 D9	3528 G9	5461 F2	7763 B8	9625 B2
L70 K7	2593 D7	3529 G9	5462 F2	9001 K3	9626 B2
L71 J8	2600 B2	3530 G10	5463 J1	9002 K4	9650 B5
L91 F4	2602 B3	3531 G10	5480 D4	9003 K4	9750 A7
L92 F2	2603 A2	3532 G10	5503 J8	9004 K5	9751 A7
L116 C9	2604 A2	3533 G10	5525 F8	9005 K3	9752 A8
L200 C7	2605 C2	3534 F10	5542 G7	9006 K4	9753 A8
L463 E2	2606 B3	3535 G10	5544 G6	9007 K4	9754 A8
1566 E8	2607 B4	3536 F10	5545 G6	9008 K5	9755 A10
1572 E8	2608 B2	3537 F10	5550 F7	9400 E3	9758 B8
1580 E8	2609 B5	3538 F10	5567 E6	9401 D2	9759 B7
2400 D3	2750 B9	3539 F10	5572 D8	9402 E1	9781 A6
2401 D3	2751 A9	3540 H7	5750 B6	9403 E1	9786 A10
2409 K3	2752 A9	3541 H7	5751 B6	9404 C1	
2410 K2	2755 B7	3542 H6	6411 K5	9405 C2	
2411 J3	2756 A6	3543 G6	6421 G5	9406 C4	
2412 K3	2760 B9	3544 G7	6422 F5	9407 E1	
2419 E5	2763 B7	3545 G8	6423 G5	9408 D2	
2420 I5	2764 C8	3553 E9	6424 F5	9409 G2	
2423 E3	2765 A7	3554 E9	6425 F3	9410 K4	
2424 G3	2766 A8	3555 D10	6426 F3	9412 C2	
2425 H5	2776 A6	3556 E10	6427 C2	9418 C5	
2426 F5	2778 A7	3557 E10	6428 D2	9419 E5	
2427 F3	2787 A7	3558 E10	6441 J2	9420 F4	
2429 D3	2788 A6	3559 D10	6450 D3	9421 H4	
2432 E3	2789 A8	3560 D10	6457 J2	9422 E4	
2433 J5	3400 E3	3561 D10	6460 G1	9423 F5	
2434 F4	3401 D2	3568 C10	6462 E2	9424 E4	
2442 J2	3402 E2	3570 E7	6463 E2	9425 F4	
2450 J2	3410 K5	3573 C6	6480 E4	9426 F4	
2451 D2	3411 J3	3579 G10	6481 D4	9427 I5	
2460 G1	3412 J3	3588 E6	6482 D4	9430 J4	
2461 G2	3414 A4	3589 D6	6501 K8	9436 G2	
2462 E2	3415 K2	3590 D6	6503 K8	9440 H4	
2463 E2	3417 J5	3591 E9	6504 J7	9441 I4	
2464 C2	3418 B4	3592 D6	6507 G8	9442 H5	
2465 E2	3420 G5	3593 D6	6508 I8	9443 E1	
2466 E2	3421 C5	3594 D6	6509 H9	9450 J3	
2470 B5	3430 H4	3595 D6	6510 J7	9451 G2	
2471 B5	3431 H4	3596 D10	6512 J7	9453 G1	
2472 D2	3432 H4	3597 C6	6513 J8	9455 G5	
2479 D4	3433 G3	3598 D9	6513 J8	9460 G2	
2480 E5	3434 G3	3601 B1	6520 H8	9461 F2	
2481 D5	3435 G3	3602 B1	6523 H8	9462 F2	
2487 C6	3436 D4	3603 A1	6524 H9	9464 D2	
2500 J9	3443 I1	3604 C3	6525 G8	9465 D3	
2501 K7	3444 D2	3605 B3	6530 G9	9466 C4	
2504 F7	3450 J1	3606 B3	6542 G7	9470 G2	
2505 I7	3451 J2	3607 B3	6545 H6	9480 D5	
2506 I10	3452 J2	3608 B3	6560 C9	9482 C5	
2507 G8	3453 J3	3609 B3	6561 D8	9507 I9	
2508 I9	3454 D3	3610 A2	6562 D8	9508 H8	
2510 J6	3455 D2	3611 A3	6567 E6	9509 C9	
2511 J7	3456 D3	3612 B4	6571 D7	9511 H8	
2512 J8	3457 J2	3613 B3	6572 D7	9522 H8	
2520 I9	3461 H1	3614 B4	6580 D8	9523 H9	
2521 G9	3462 F2	3615 A2	6590 D6	9526 F9	
2522 G9	3463 F2	3616 A2	6591 C7	9538 E10	
2523 G9	3464 D2	3617 B2	6592 E9	9540 G6	
2524 F9	3465 B5	3618 C1	6600 B4	9541 H8	
2525 G8	3466 B5	3619 C2	6601 A2	9544 F9	
2526 F9	3467 B5	3620 B4	6610 C4	9545 H6	
2528 G9	3470 B5	3621 C3	6750 B6	9550 I6	
2530 G9	3472 F2	3623 A1	6751 B6	9555 I10	
2531 G10	3478 D5	3624 A2	6763 B7	9556 I10	
2533 G10	3479 D5	3625 B2	6764 B8	9560 C8	
2534 F10	3480 D5	3626 C1	7410 K3	9561 C8	
2535 F10	3481 D5	3627 B1	7411 D2	9562 C10	
2538 F10	3482 C5	3750 B6	7420 I5	9567 E7	
2540 H7	3483 E5	3751 B6	7421 H5	9568 E7	
2541 H8	3484 E5	3752 A6	7450 D3	9573 C6	
2542 H7	3487 D4	3753 A8	7480 D5	9574 C6	
2543 G7	3488 G7	3500 K10	7507 I9	9575 C7	
2544 G7	3502 G8	3755 A9	7520 F9		

For Service Manuals Contact  
**MAURITRON TECHNICAL SERVICES**  
 8 Cherry Tree Rd, Chinnor  
 Oxon OX9 4QY  
 Tel: 01844-351694 Fax: 01844-352554  
 Email: enquiries@mauritron.co.uk

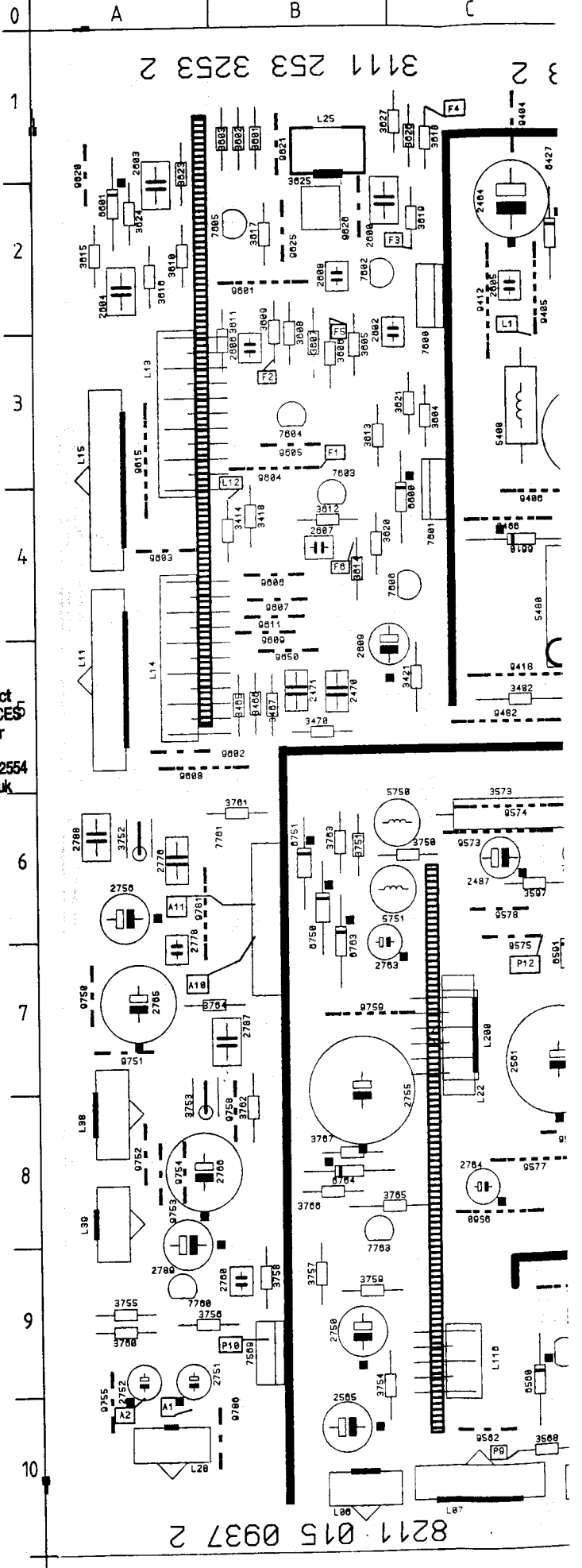



F G H I J K

LARGE SIGNAL A

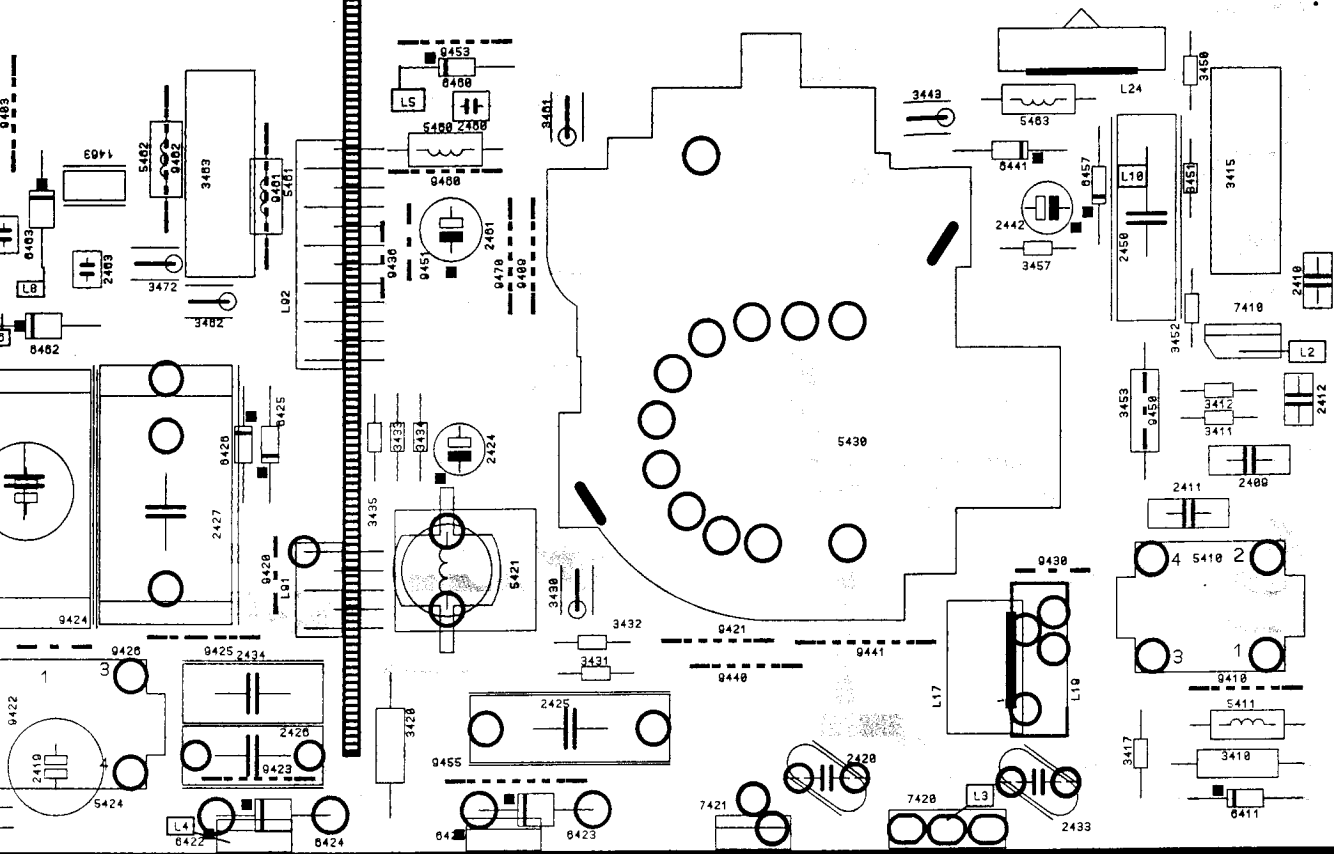

- 0001
- 0002
- 0003
- 0004
- 0005
- 0006
- 0007
- 0008
- 0009
- 0010

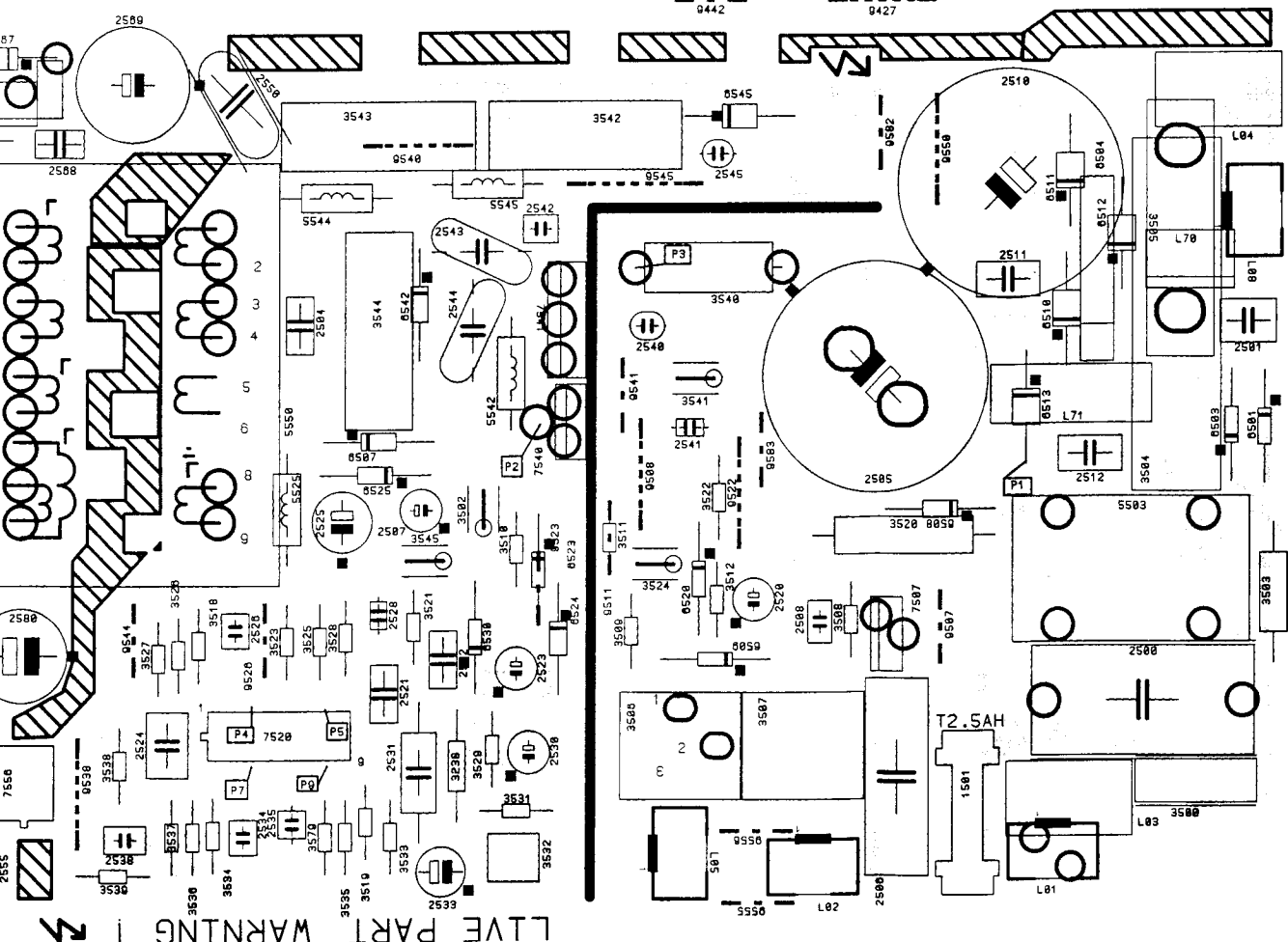

LIVE PART WARNING

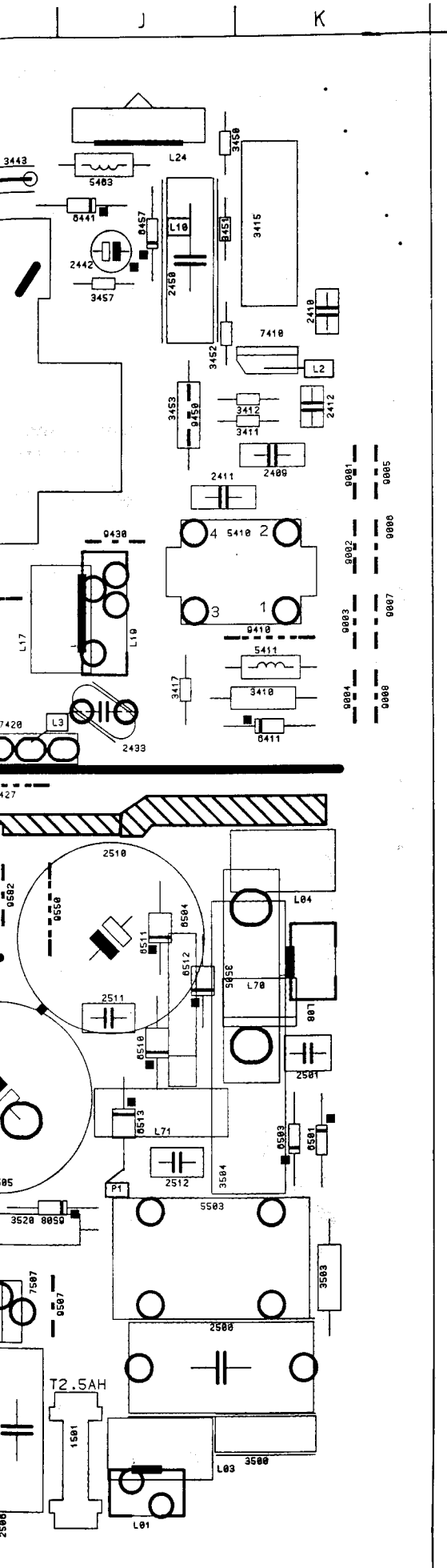

For Service Manuals Contact  
**MAURITRON TECHNICAL SERVICES**  
 8 Cherry Tree Rd, Chinnor  
 Oxon OX9 4QY  
 Tel:- 01844-351694 Fax:- 01844-352554  
 Email:- enquiries@mauritron.co.uk





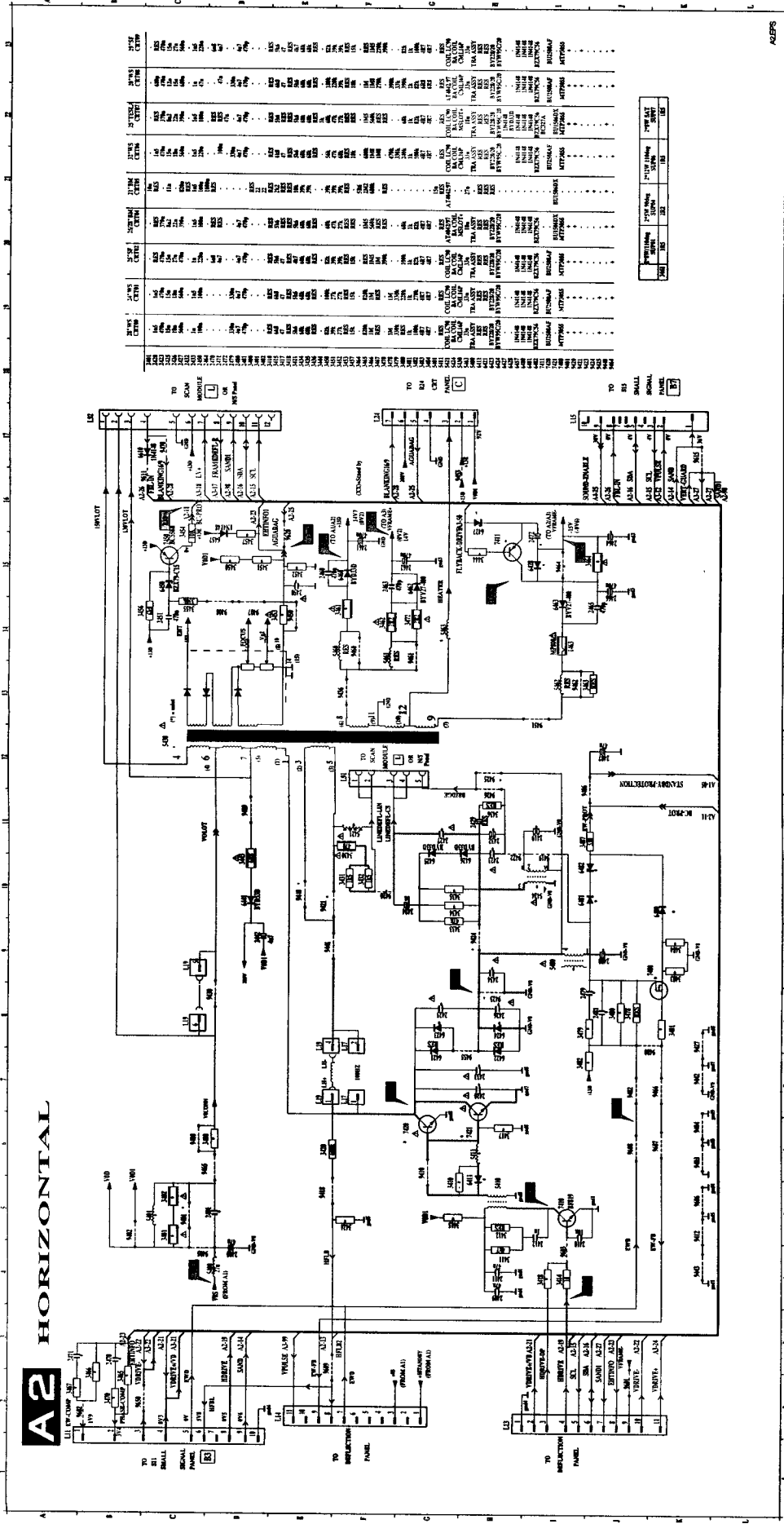

For Service Manuals Contact  
**MAURITRON TECHNICAL SERVICES**  
 8 Cherry Tree Rd, Chinnor  
 Oxon OX9 4QY  
 Tel: 01844-351694 Fax: 01844-352554  
 Email: enquiries@maurtron.co.uk

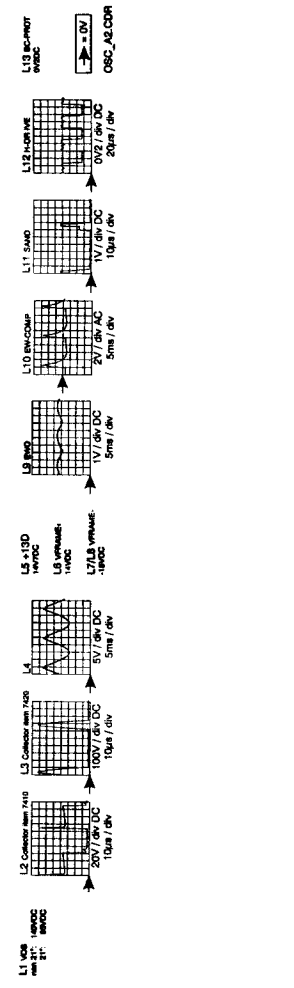



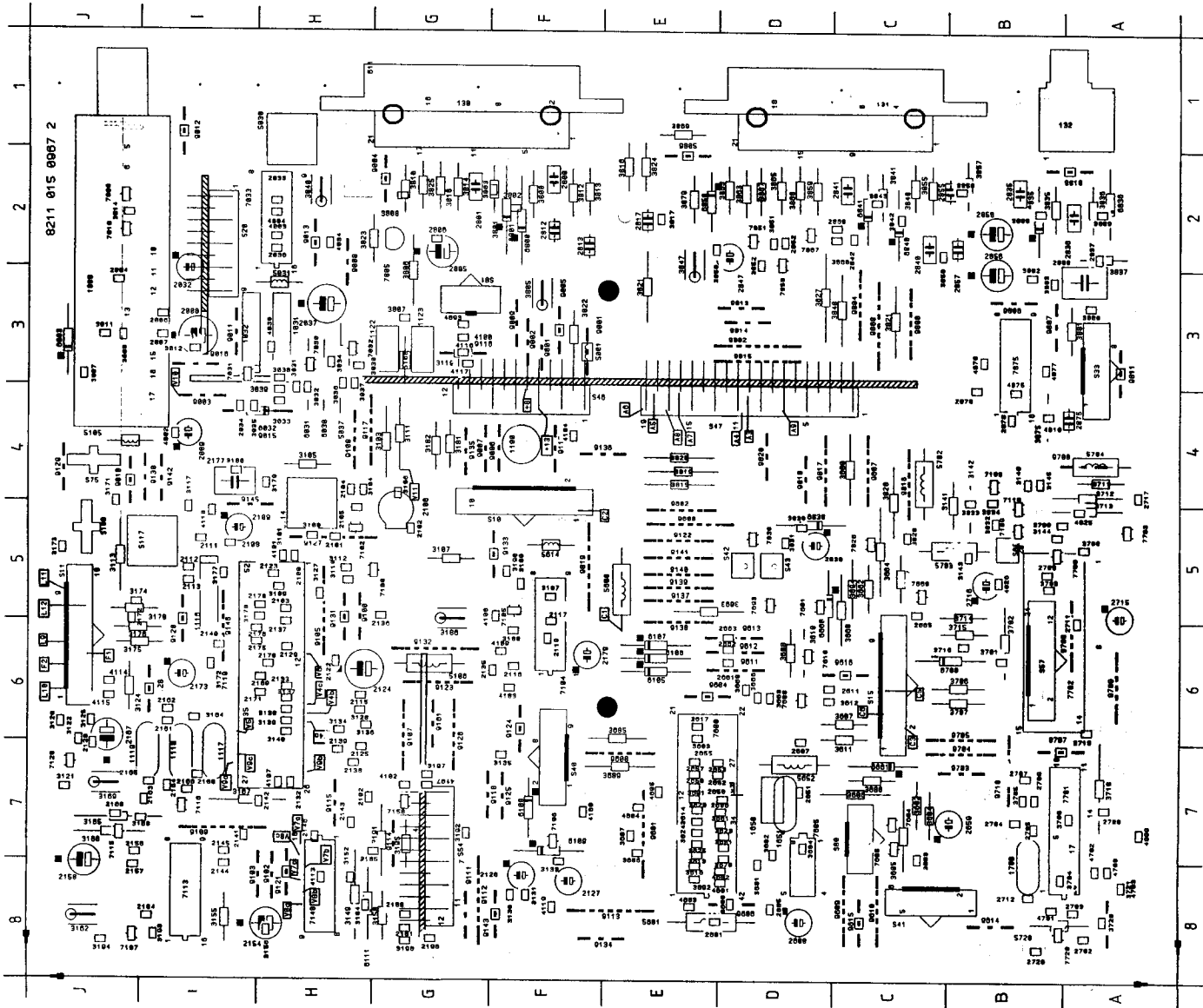

S11	J6	3658	H3	3613	E7	3852	D2	6856	A2	9135	G4
S15	C6	3659	H3	3614	E7	3853	D2	6840	C2	9136	F4
S20	J6	3620	H3	3615	E7	3854	D2	6855	E2	9137	H4
S33	A7	3621	H3	3616	E7	3855	D2	6850	E2	9138	E5
S40	F7	3622	H3	3617	E7	3856	D2	7008	E2	9139	E5
S41	C8	3100	H5	3623	E3	3658	B2	7010	H3	9140	E5
S42	D5	3101	H5	3624	D7	3659	D2	7030	H3	9141	E5
S43	D5	3103	G4	3625	E7	3660	C2	7031	H3	9142	A4
S44	F4	3104	H4	3626	E7	3663	D2	7032	H3	9143	F8
S45	D4	3105	H4	3627	D3	3665	D2	7033	H2	9144	I4
S47	G6	3106	G4	3628	D3	3666	D2	7100	H5	9145	I4
S49	B6	3107	G5	3629	D3	3667	D2	7102	H5	9161	G8
S50	B6	3108	H5	3630	D3	3668	D2	7103	H5	9162	G8
S52	B6	3109	H5	3631	D3	3669	D2	7104	H5	9163	G8
S75	J4	3110	H5	3632	D3	3670	D2	7105	F5	9164	G8
S80	C3	3111	G4	3633	D3	3671	D2	7106	F7	9165	G8
S91	G3	3112	G4	3634	D3	3672	D2	7107	F7	9166	G8
S100	J5	3113	J5	3635	D6	3673	D2	7108	B4	9167	C8
S130	F1	3114	J5	3636	D6	3674	D2	7109	B4	9168	C8
S131	C1	3115	J5	3637	D7	3675	D2	7110	B4	9169	C8
S132	A1	3116	J5	3638	D8	3676	D2	7111	B4	9170	C8
S133	H1	3117	J5	3639	D8	3677	D2	7112	B4	9171	C8
S134	H1	3118	J5	3640	D8	3678	D2	7113	B4	9172	C8
S135	H1	3119	J5	3641	D8	3679	D2	7114	B4	9173	C8
S136	H1	3120	J5	3642	D8	3680	D2	7115	J7	9174	C8
S137	H1	3121	J5	3643	D8	3681	D2	7116	J7	9175	C8
S138	H1	3122	J5	3644	D8	3682	D2	7117	J7	9176	C8
S139	H1	3123	J5	3645	D8	3683	D2	7118	J7	9177	C8
S140	H1	3124	J5	3646	D8	3684	D2	7119	J7	9178	C8
S141	H1	3125	J5	3647	D8	3685	D2	7120	J7	9179	C8
S142	H1	3126	J5	3648	D8	3686	D2	7121	J7	9180	C8
S143	H1	3127	H5	3649	E7	4025	A4	7140	H6	9614	B8
S144	H1	3128	H5	3650	E7	4026	A4	7141	H6	9615	B8
S145	H1	3129	H5	3651	E7	4027	A4	7142	H6	9616	B8
S146	H1	3130	F8	3652	E7	4028	B5	7150	F7	9617	B8
S147	H1	3131	F8	3653	E7	4029	B5	7151	F7	9618	B8
S148	H1	3132	F8	3654	E7	4030	H3	7600	E7	9700	A4
S149	H1	3133	F8	3655	E7	4031	H3	7601	D5	9701	A4
S150	H1	3134	H5	3656	E8	4100	G3	7604	C7	9703	B7
S151	H1	3135	H5	3657	E8	4101	G3	7605	C7	9704	B7
S152	H1	3136	H5	3658	E8	4102	G7	7606	D8	9705	B6
S153	H1	3137	H5	3659	E8	4103	F8	7610	D6	9707	B7
S154	H1	3138	H5	3660	E8	4104	F8	7611	D6	9708	A6
S155	H1	3139	H5	3661	E8	4105	F8	7612	D6	9709	A6
S156	H1	3140	H5	3662	E8	4106	F8	7613	D6	9710	B7
S157	H1	3141	B4	3663	E7	4107	H7	7683	D5	9710	B7
S158	H1	3142	B4	3664	E7	4108	F8	7700	B5	9720	A8
S159	H1	3143	B5	3665	E7	4109	F8	7701	A7	9801	F3
S160	H1	3144	B5	3666	E7	4110	F8	7702	B6	9802	D3
S161	H1	3145	B5	3667	E7	4111	J6	7703	A5	9803	F3
S162	H1	3146	B5	3668	E7	4112	J6	7720	B8	9804	C3
S163	H1	3147	B5	3669	E7	4113	G3	7721	B8	9805	E1
S164	H1	3148	B5	3670	B6	4114	G3	7722	B8	9806	E1
S165	H1	3149	B5	3671	B6	4115	G3	7723	B8	9807	B3
S166	H1	3150	B5	3672	B6	4116	G3	7724	B8	9808	B3
S167	H1	3151	B5	3673	B6	4117	G3	7725	B8	9809	B3
S168	H1	3152	B5	3674	B6	4118	G3	7726	B8	9810	B3
S169	H1	3153	B5	3675	B6	4119	G3	7727	B8	9811	A2
S170	H1	3154	B5	3676	B6	4120	G3	7728	B8	9812	A2
S171	H1	3155	B5	3677	B6	4121	G3	7729	B8	9813	A2
S172	H1	3156	B5	3678	B6	4122	G3	7730	B8	9814	D3
S173	H1	3157	B5	3679	B6	4123	G3	7731	B8	9815	D3
S174	H1	3158	B5	3680	B6	4124	G3	7732	B8	9816	D3
S175	H1	3159	B5	3681	B6	4125	G3	7733	B8	9817	D4
S176	H1	3160	B5	3682	B6	4126	G3	7734	B8	9818	D4
S177	H1	3161	B5	3683	B6	4127	G3	7735	B8	9819	D4
S178	H1	3162	B5	3684	B6	4128	G3	7736	B8	9820	D4
S179	H1	3163	B5	3685	B6	4129	G3	7737	B8	9821	D4
S180	H1	3164	B5	3686	B6	4130	G3	7738	B8	9822	D4
S181	H1	3165	B5	3687	B6	4131	G3	7739	B8	9823	D4
S182	H1	3166	B5	3688	B6	4132	G3	7740	B8	9824	D4
S183	H1	3167	B5	3689	B6	4133	G3	7741	B8	9825	D4
S184	H1	3168	B5	3690	B6	4134	G3	7742	B8	9826	D4
S185	H1	3169	B5	3691	B6	4135	G3	7743	B8	9827	D4
S186	H1	3170	B5	3692	B6	4136	G3	7744	B8	9828	D4
S187	H1	3171	B5	3693	B6	4137	G3	7745	B8	9829	D4
S188	H1	3172	B5	3694	B6	4138	G3	7746	B8	9830	D4
S189	H1	3173	B5	3695	B6	4139	G3	7747	B8	9831	D4
S190	H1	3174	B5	3696	B6	4140	G3	7748	B8	9832	D4
S191	H1	3175	B5	3697	B6	4141	G3	7749	B8	9833	D4
S192	H1	3176	B5	3698	B6	4142	G3	7750	B8	9834	D4
S193	H1	3177	B5	3699	B6	4143	G3	7751	B8	9835	D4
S194	H1	3178	B5	3700	B6	4144	G3	7752	B8	9836	D4
S195	H1	3179	B5	3701	B6	4145	G3	7753	B8	9837	D4
S196	H1	3180	B5	3702	B6	4146	G3	7754	B8	9838	D4
S197	H1	3181	B5	3703	B6	4147	G3	7755	B8	9839	D4
S198	H1	3182	B5	3704	B6	4148	G3	7756	B8	9840	D4
S199	H1	3183	B5	3705	B6	4149	G3	7757	B8	9841	D4
S200	H1	3184	B5	3706	B6	4150	G3	7758	B8	9842	D4
S201	H1	3185	B5	3707	B6	4151	G3	7759	B8	9843	D4
S202	H1	3186	B5	3708	B6	4152	G3	7760	B8	9844	D4
S203	H2	2705	B7	3162	J8	3715	B6	4603	E8	9001	F3
S204	H2	2706	B7	3163	J8	3716	B6	4604	E7	9002	F3
S205	H2	2707	B7	3164	J8	3717	B6	4605	E7	9003	F3
S206	H2	2708	B7	3165	J7	3720	A8	4805	E7	9004	G2
S207	H2	2709	B7	3166	J7	3721	A8	4806	E7	9005	F3
S208	H2	2710	A8	3167	J7	3722	A8	4807	E7	9006	F3
S209	H2	2711	A8	3168	J7	3723	A8	4808	E7	9007	F3
S210	H2	2712	A8	3169	J7	3724	A8	4809	E7	9008	F3
S211	H2	2713	A8	3170	J7	3725	A8	4810	E7	9009	H2
S212	H2	2714	A8	3171	J7	3726	A8	4811	E7	9010	J4
S213	H2	2715	A8	3172	J7	3727	A8	4812	E7	9011	J4
S214	H2	2716	A8	3173	J7	3728	A8	4813	E7	9012	H2
S215	H2	2717	A8	3174	J7	3729	A8	4814	E7	9013	H2
S216	H2	2718	A8	3175	J7	3730	A8	4815	E7	9014	H2
S217	H2	2719	A8	3176	J7	3731	A8	4816	E7	9015	H2
S218	H2	2720	A8	3177	J7	3732	A8	4817	E7	9016	H2
S219	H2	2721	A8	3178	J7	3733	A8	4818	E7	9017	H2
S220	H2	2722	A8	3179	J7	3734	A8	4819	E7	9018	H2
S221	H2	2723	A8	3180	J7	3735	A8	4820	E7	9019	H2
S222	H2	2724	A8	3181	J7	3736	A8	4821	E7	9020	H2
S223	H2	2725	A8	3182	J7	3737	A8	4822	E7	9021	H2
S224	H2	2726	A8	3183	J7	3738	A8	4823	E7	9022	H2
S225	H2	2727	A8	3184	J7	3739	A8	4824	E7	9023	H2
S226	H2	2728	A8	3185	J7	3740	A8	4825	E7	9024	H2
S227	H2	2729	A8	3186	J7	3741	A8	4826	E7	9025	H2
S228	H2	2730	A8	3187	J7	3742	A8	4827	E7	9026	H2
S229	H2	2731	A8	3188	J7	3743	A8	4828	E7	9027	H2
S230	H2	2732	A8	3189	J7	3744	A8	4829	E7	9028	H2
S231	H2	2733	A8	3190	J7	3745	A8	4830	E7	9029	H2
S232	H2	2734	A8	3191	J7	3746	A8	4831	E7	9030	H2
S233	H2	2735	A8	3192	J7	3747	A8	4832	E7	9031	H2
S234	H2	2736	A8	3193	J7	3748	A8	4833	E7	9032	H2
S235	H2	2737	A8	3194	J7	3749	A8	4834	E7	9033	H2
S236	H2	2738	A8	3195	J7	3750	A8	4835	E7	9034	H2
S237	H2	2739	A8	3196	J7	3751	A8	4836	E7	9035	H2
S238	H2	2740	A8	3197	J7	3752	A8	4837	E7	9036	H2
S239	H2	2741	A8	3198	J7	3753	A8	4838	E7	9037	H2
S240	H2	2742	A8	3199	J7	3754					

1000 C 1	2005 E 1	3101 A 9	2106 B 9	2113 E 9	3007 E 5	3101 C 1	3110 E 3	4100 D 6	5106 C 4	7010 F 4	9127 B 3	81-01 E 7	81-52 G 7	5190 H 5
1122 D 4	2008 F 3	3103 E 2	2109 F 0	2123 C 1	3012 F 5	3105 A 9	3117 D 3	4118 C 8	5114 B 9	7102 B 9	9140 F 7	81-29 D 7	81-74 G 7	5175 H 4
1223 E 4	2009 B 1	3104 B 7	2111 D 5	2129 C 4	3014 F 4	3106 C 9	3117 D 8	4119 C 8	5115 B 7	7119 D 0	9145 D 5	84-39 B 7	84-19 D 17	5145 H 4
2004 E 4	2100 C 1	3105 C 1	2112 D 5	2130 C 1	3015 F 1	3107 E 1	3119 D 3	4120 D 7	5116 B 7	7119 D 0	9116 D 5	84-39 B 7	84-19 D 17	5145 H 4
												85-19 D 17	85-20 E 17	5146 H 4

**B1** TUNER + IF (BIMOS-IC)

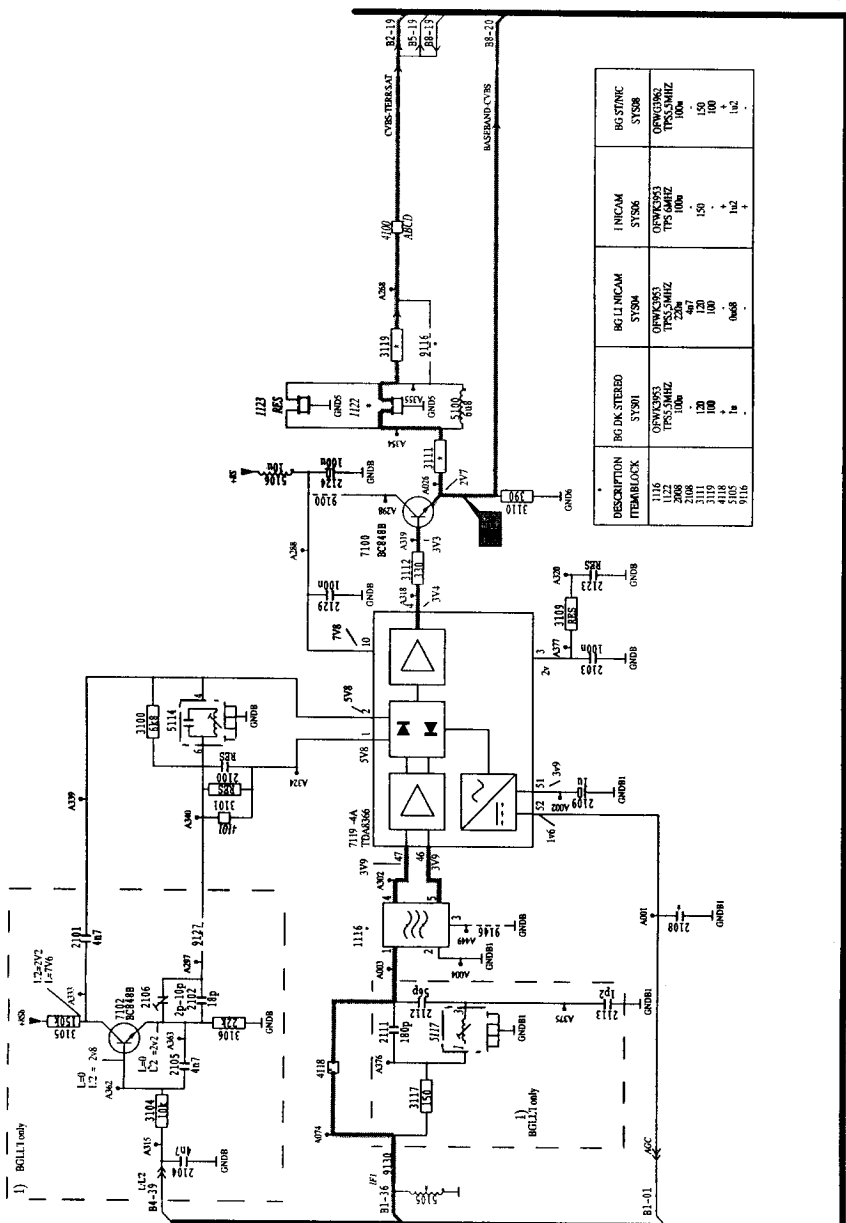
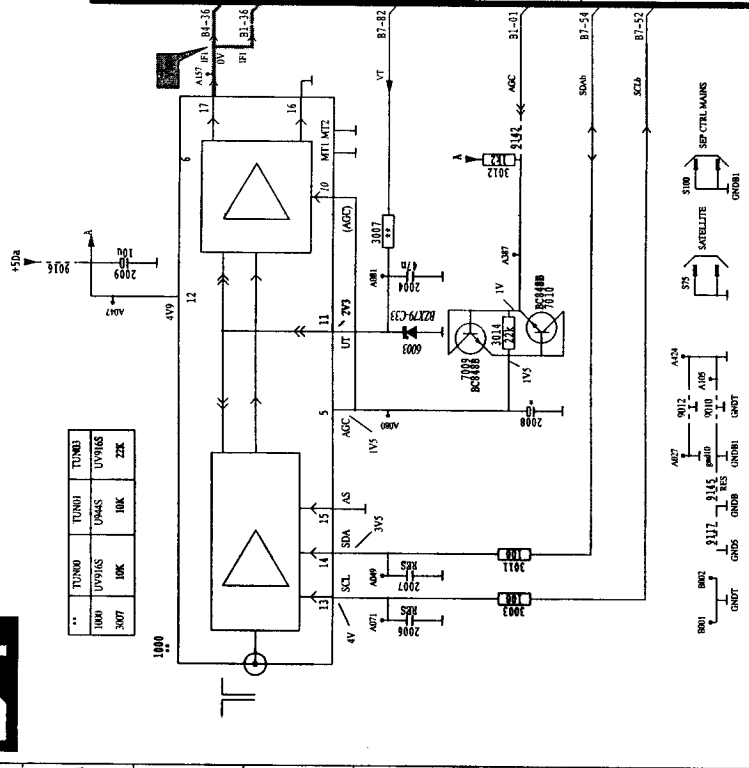

DESCRIPTION ITEM/BLOCK	BD DK STEREO SYS80	BEL LICAM SYS84	FINICAM SYS86	BO STINE SYS88
1115	OPW4393	OPW4393	OPW4393	OPW4393
1122	TPSS.5AMHZ	TPSS.5AMHZ	TPSS.5AMHZ	TPSS.5AMHZ
2008	100µ	100µ	100µ	100µ
3111	150	150	150	150
4119	100	100	100	100
5105	1µ	1µ	1µ	1µ
9116	1µ	1µ	1µ	1µ

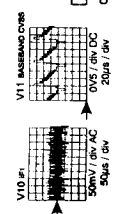

B1.CDR MD 1.2



# Video processing / Video Verarbeitung / Traitement video

## B2 VIDEO PROCESSING (BIMOS-IC)

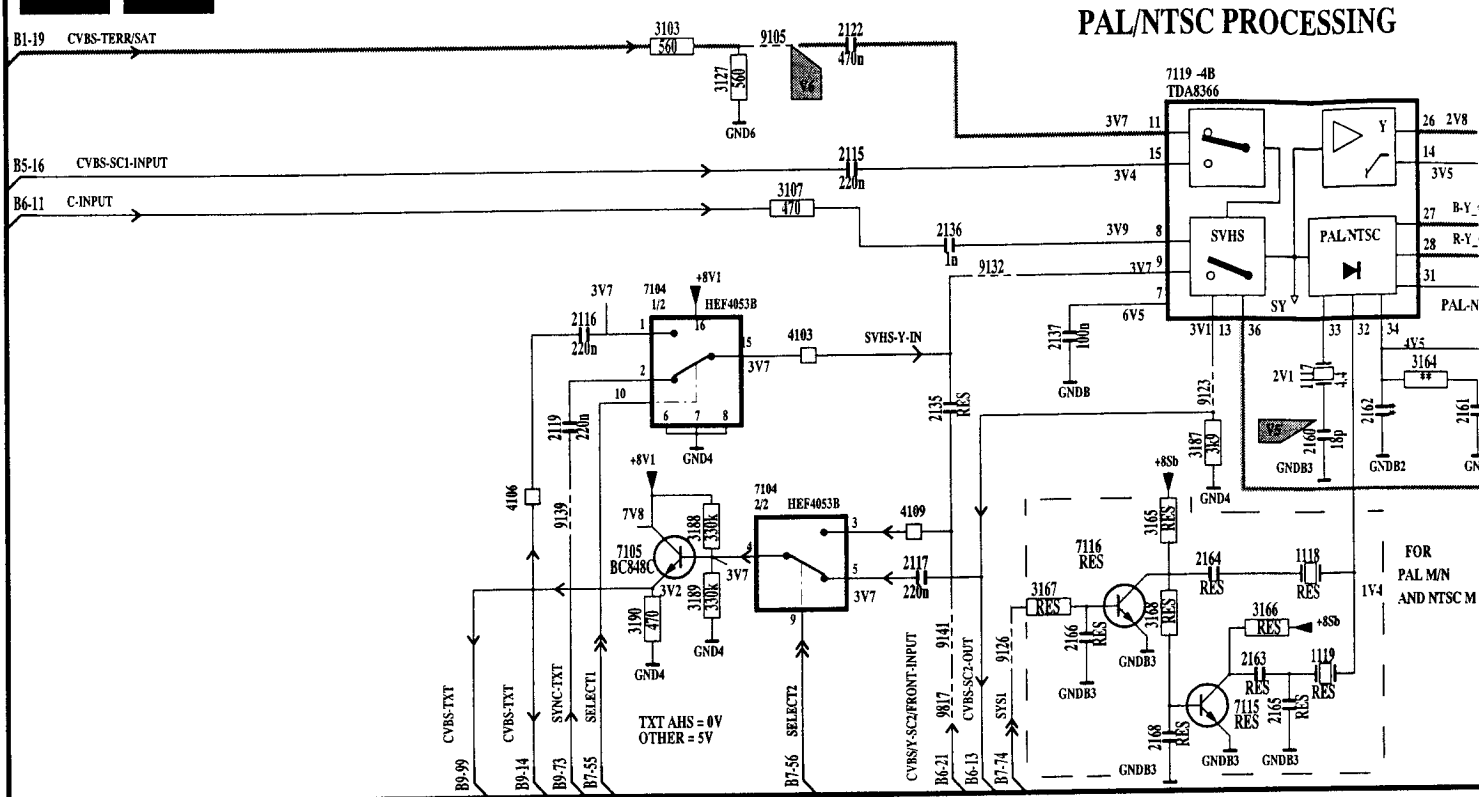

*	CTI/HIST	BLKSTR	NO CTI/BLK/HIST	CTI/BLKSTR	WS
	PCT 00	PCT 01	PCT 02	PCT 03	PCT 04
2180	220	-	-	220	-
2181	220	-	-	220	-
3195	-	-	1K	-	1K
3197	1k5	-	-	-	-
4102	+	+	-	+	+
4119	+	+	-	+	+
4197	-	+	-	+	+
9102	-	+	+	-	+
9103	-	+	+	-	+
9113	-	+	-	res	-

**	pal/secam STD00	pal STD02
2161	470n	100n
2162	4n7	3m9
3164	18k	100k
3193	jump	-

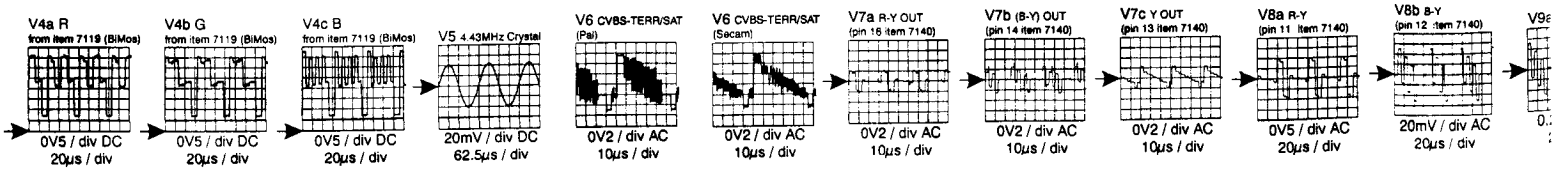
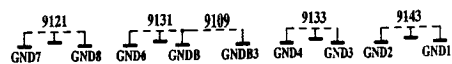
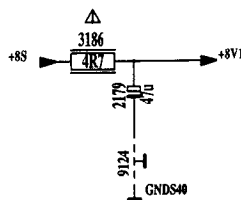

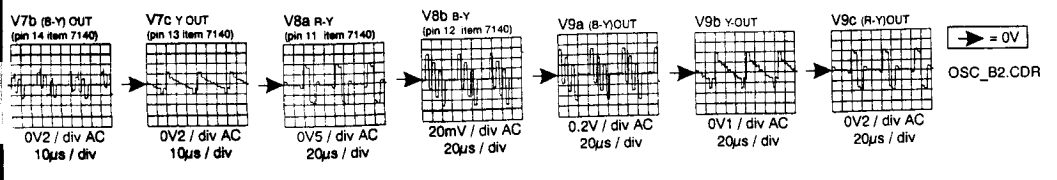
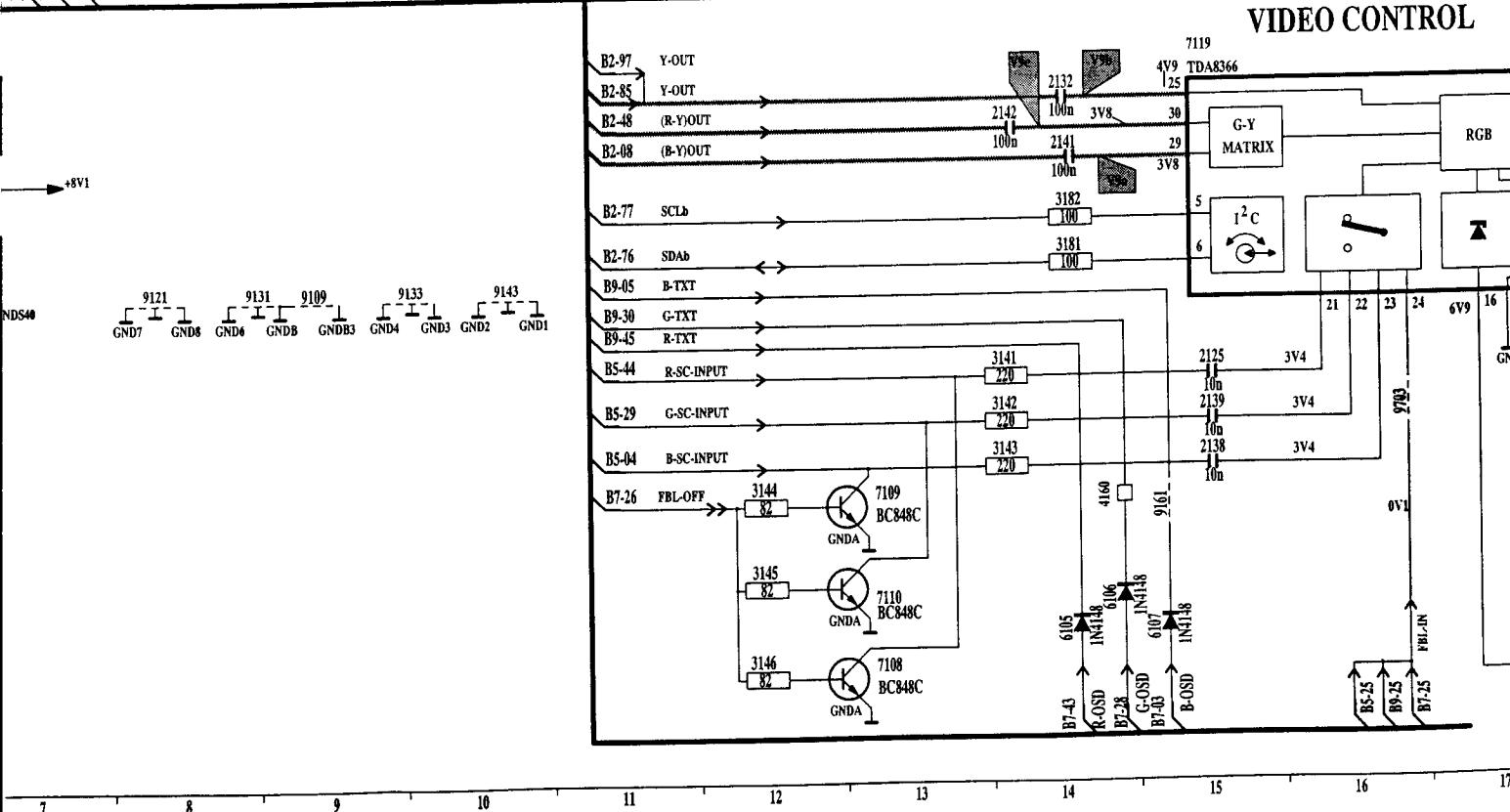
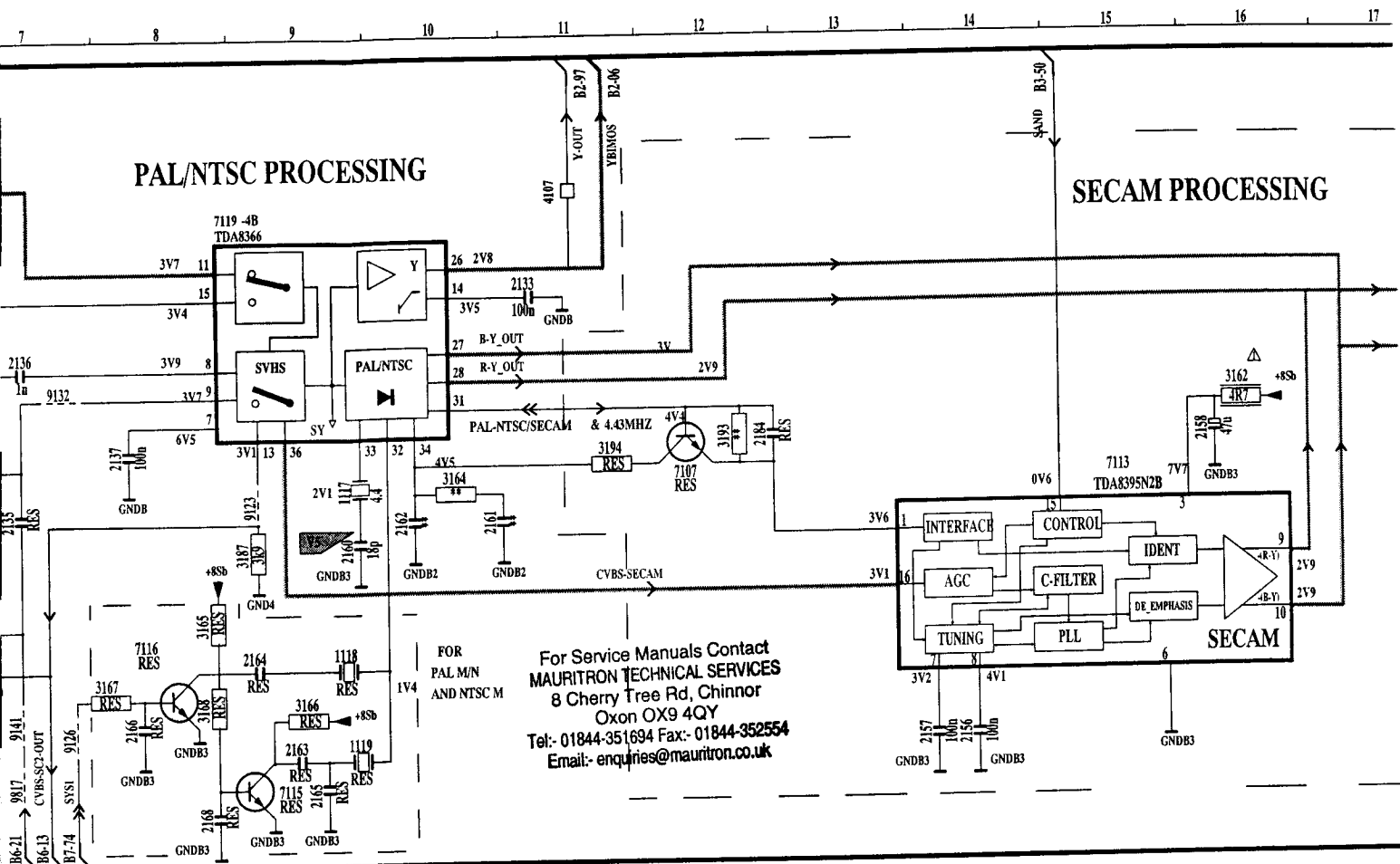







- B3-01
- B3-02
- B3-03
- B3-04
- B3-05
- B3-06
- B3-07
- B3-08
- B3-09
- B3-10
- B3-11
- B3-12
- B3-13
- B3-14
- B3-15
- B3-16
- B3-17
- B3-18
- B3-19
- B3-20
- B3-21
- B3-22
- B3-23
- B3-24
- B3-25
- B3-26
- B3-27
- B3-28
- B3-29
- B3-30
- B3-31
- B3-32
- B3-33
- B3-34
- B3-35
- B3-36
- B3-37
- B3-38
- B3-39
- B3-40
- B3-41
- B3-42
- B3-43
- B3-44
- B3-45
- B3-46
- B3-47
- B3-48
- B3-49
- B3-50
- B3-51
- B3-52
- B3-53
- B3-54
- B3-55
- B3-56
- B3-57
- B3-58
- B3-59
- B3-60
- B3-61
- B3-62
- B3-63
- B3-64
- B3-65
- B3-66
- B3-67
- B3-68
- B3-69
- B3-70
- B3-71
- B3-72
- B3-73
- B3-74
- B3-75
- B3-76
- B3-77
- B3-78
- B3-79
- B3-80
- B3-81
- B3-82
- B3-83
- B3-84
- B3-85
- B3-86
- B3-87
- B3-88
- B3-89
- B3-90
- B3-91
- B3-92
- B3-93
- B3-94
- B3-95
- B3-96
- B3-97
- B3-98
- B3-99
- B3-100

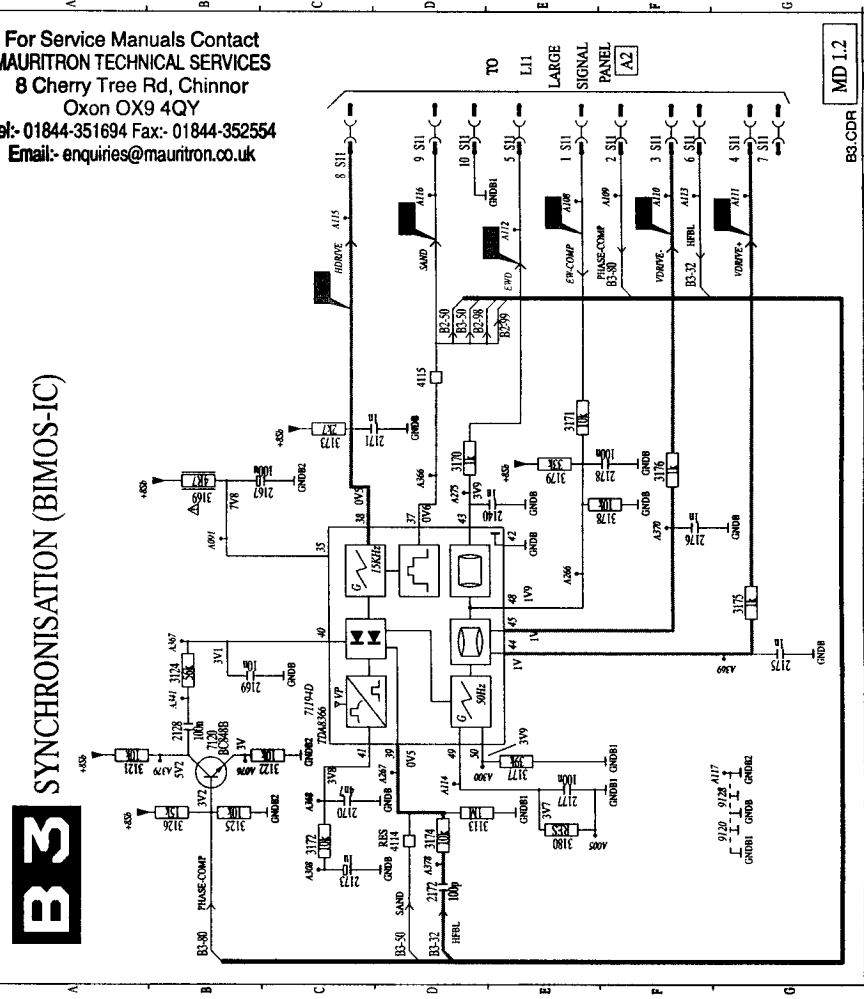

- F1 VOLTAGE 0V5 / DIV DC 5ms / DIV
- F2 VOLTAGE 0V5 / DIV DC 5ms / DIV
- F3 VOLTAGE 1V / DIV DC 5ms / DIV
- F4 VOLTAGE 2V / DIV AC 5ms / DIV
- F5 WAVEFORM 1V / DIV DC 10ms / DIV
- F6 WAVEFORM 1V / DIV DC 20ms / DIV
- F7 WAVEFORM 0V2 / DIV DC 20ms / DIV
- F8 WAVEFORM 0V / DIV DC 20ms / DIV

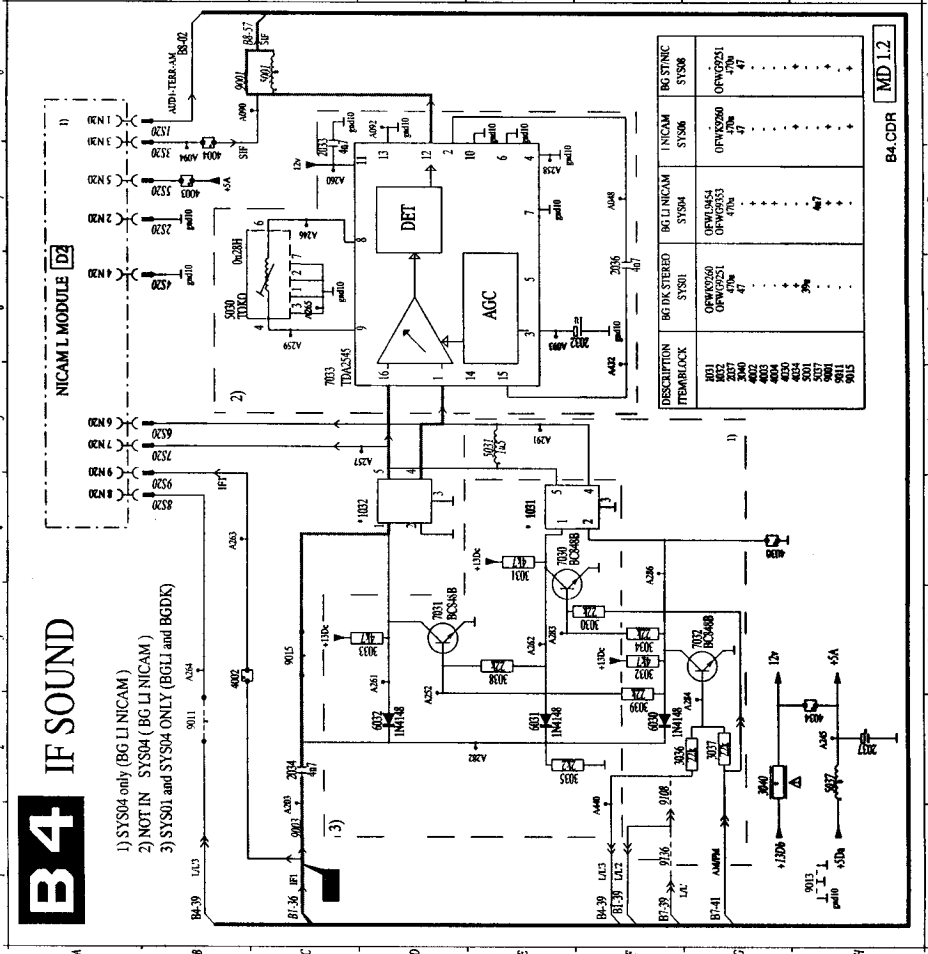

- B4-01
- B4-02
- B4-03
- B4-04
- B4-05
- B4-06
- B4-07
- B4-08
- B4-09
- B4-10
- B4-11
- B4-12
- B4-13
- B4-14
- B4-15
- B4-16
- B4-17
- B4-18
- B4-19
- B4-20
- B4-21
- B4-22
- B4-23
- B4-24
- B4-25
- B4-26
- B4-27
- B4-28
- B4-29
- B4-30
- B4-31
- B4-32
- B4-33
- B4-34
- B4-35
- B4-36
- B4-37
- B4-38
- B4-39
- B4-40
- B4-41
- B4-42
- B4-43
- B4-44
- B4-45
- B4-46
- B4-47
- B4-48
- B4-49
- B4-50
- B4-51
- B4-52
- B4-53
- B4-54
- B4-55
- B4-56
- B4-57
- B4-58
- B4-59
- B4-60
- B4-61
- B4-62
- B4-63
- B4-64
- B4-65
- B4-66
- B4-67
- B4-68
- B4-69
- B4-70
- B4-71
- B4-72
- B4-73
- B4-74
- B4-75
- B4-76
- B4-77
- B4-78
- B4-79
- B4-80
- B4-81
- B4-82
- B4-83
- B4-84
- B4-85
- B4-86
- B4-87
- B4-88
- B4-89
- B4-90
- B4-91
- B4-92
- B4-93
- B4-94
- B4-95
- B4-96
- B4-97
- B4-98
- B4-99
- B4-100

**B4** IF SOUND

- 1) SYS04 only (BG LI NICAM)
- 2) NOT IN SYS04 (BG LI NICAM)
- 3) SYS01 and SYS04 ONLY (BGLI and BGDK)

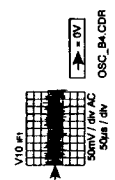

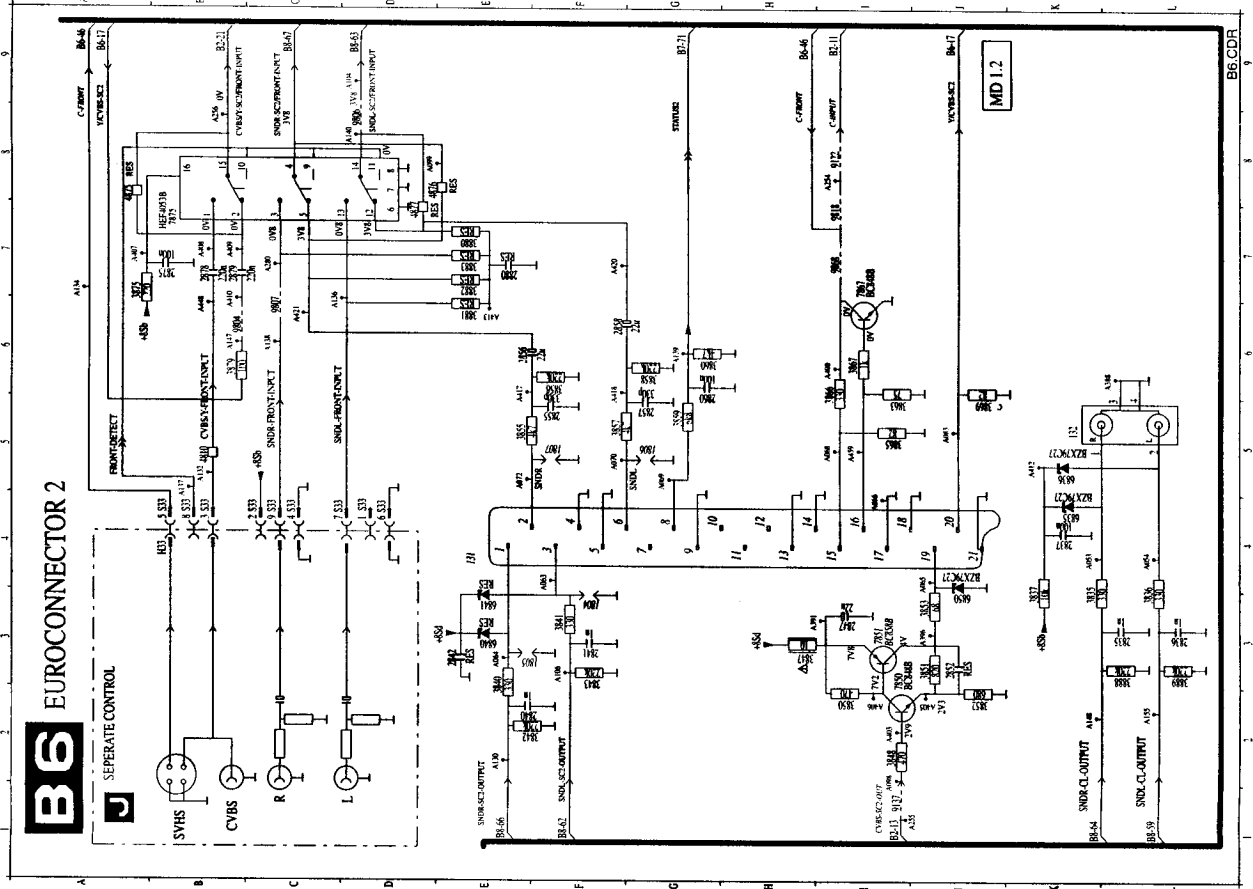
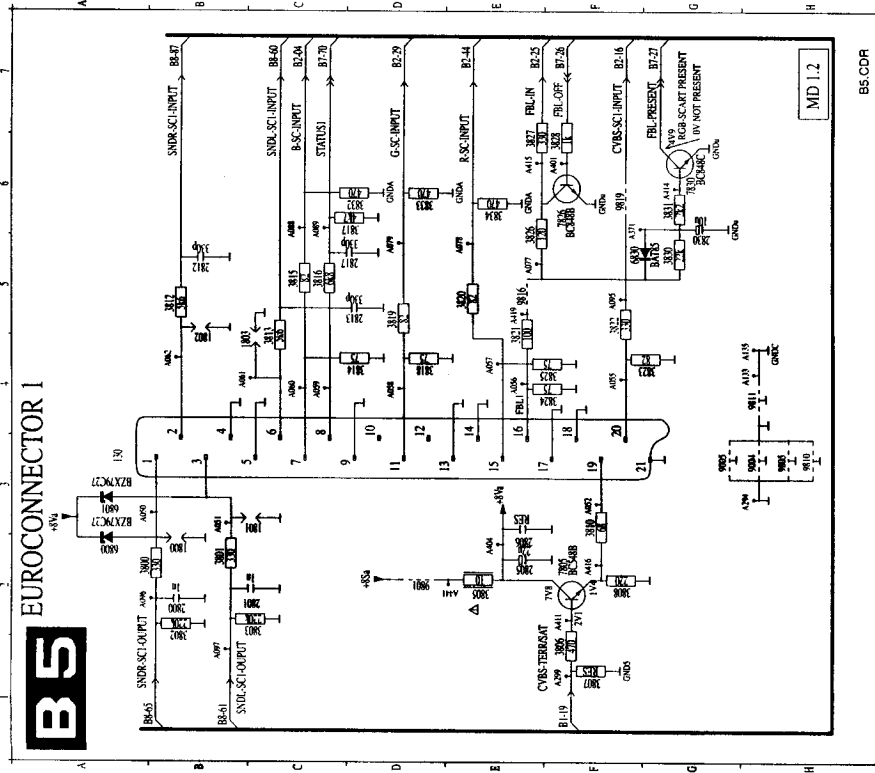

**B7** CONTROLS

DESCRIPTION	REG STEREO	REG LINC/AM	REG C/AM	REG SYNC	REG STEREO
341	487	487	487	487	487
342	487	487	487	487	487
343	487	487	487	487	487

DESCRIPTION	REG STEREO	REG LINC/AM	REG C/AM	REG SYNC	REG STEREO
344	487	487	487	487	487
345	487	487	487	487	487
346	487	487	487	487	487
347	487	487	487	487	487
348	487	487	487	487	487
349	487	487	487	487	487
350	487	487	487	487	487

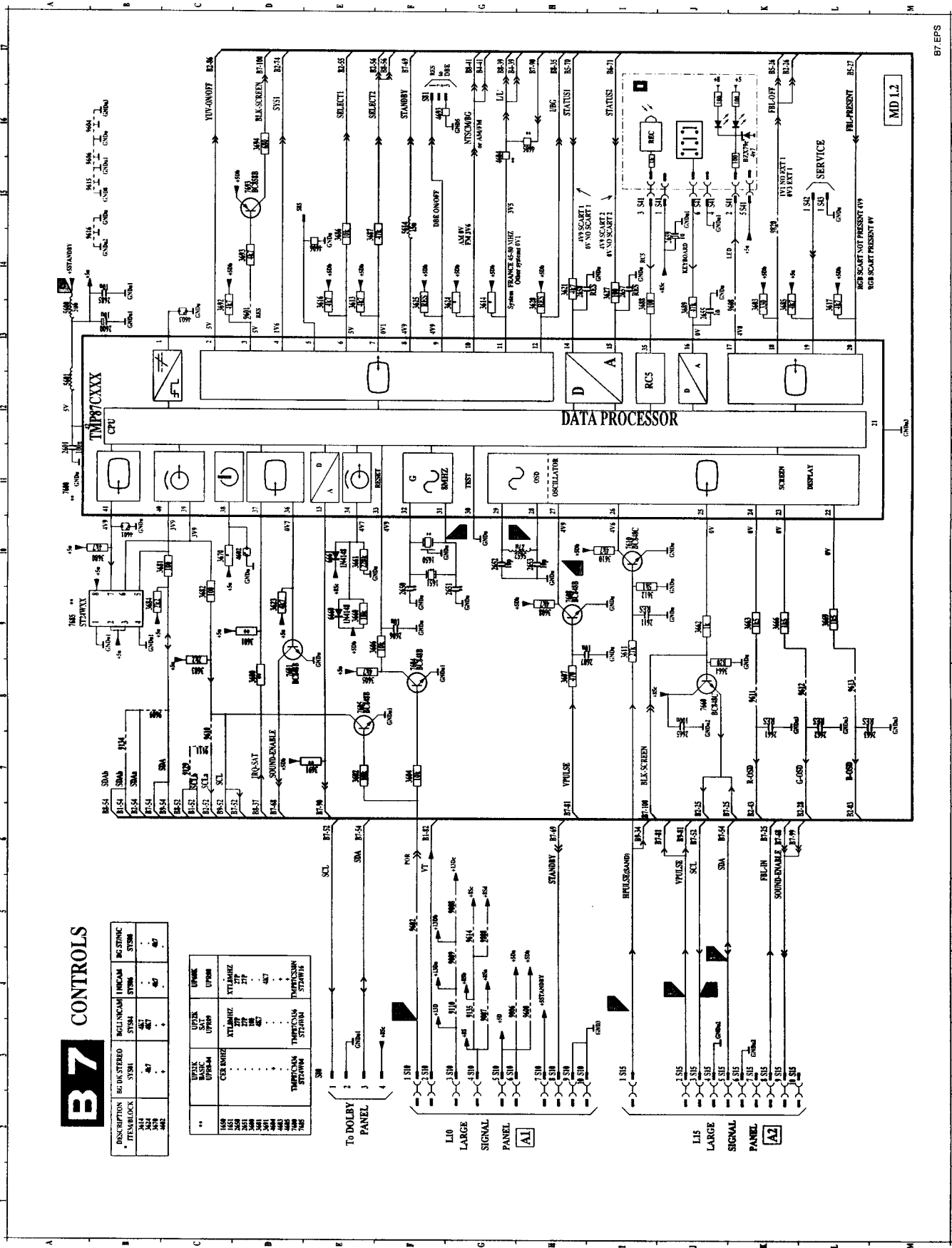

MD 1.2

C1 +5VSTANDBY  
(Pin 42 Item 7600)  
5VDC

C2 POR (① to ②)  
0V / 5V  
POR (② to ①)  
5V / 0V

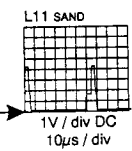
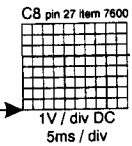
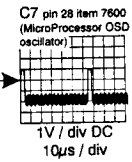
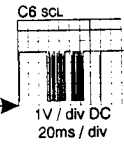
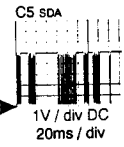
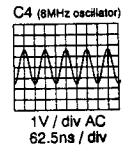
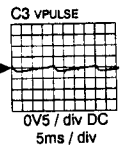

→ = 0V

OSC B7.CDR

For Service Manuals Contact  
**MAURITRON TECHNICAL SERVICES**  
8 Cherry Tree Rd, Chinnor  
Oxon OX9 4QY  
Tel:- 01844-351694 Fax:- 01844-352554  
Email:- enquiries@mauritron.co.uk

# Connections audio module / Verbindungen Audio Modul / Connections de module audio

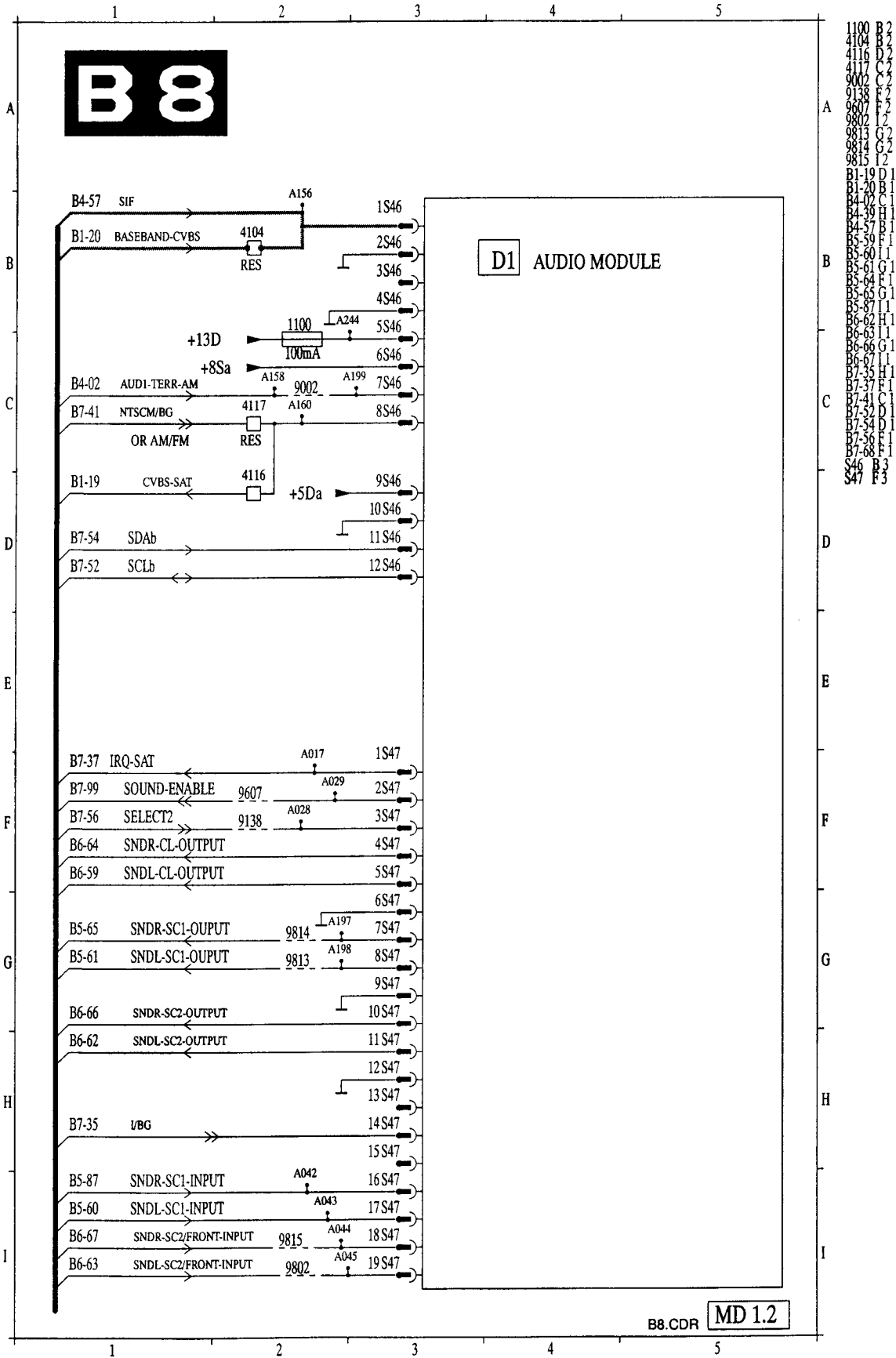

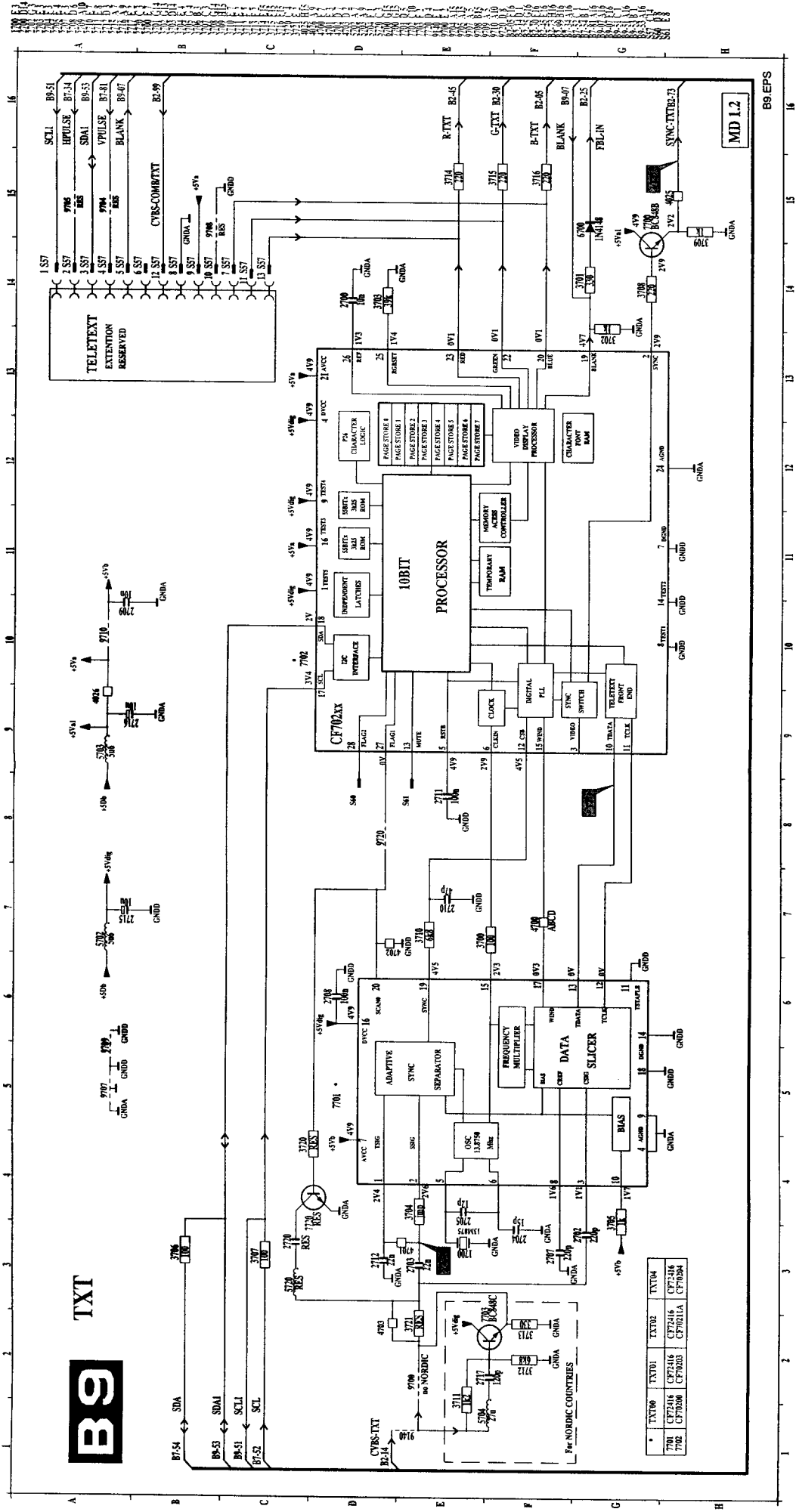

For Service Manuals Contact  
**MAURITRON TECHNICAL SERVICES**  
 8 Cherry Tree Rd, Chinnor  
 Oxon OX9 4QY  
 Tel: 01844-351694 Fax: 01844-352554  
 Email: enquiries@mauritron.co.uk

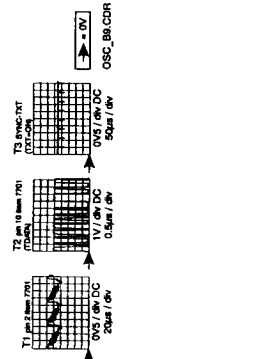





# CRT panel / CRT-Platine / Platine tube cathodique

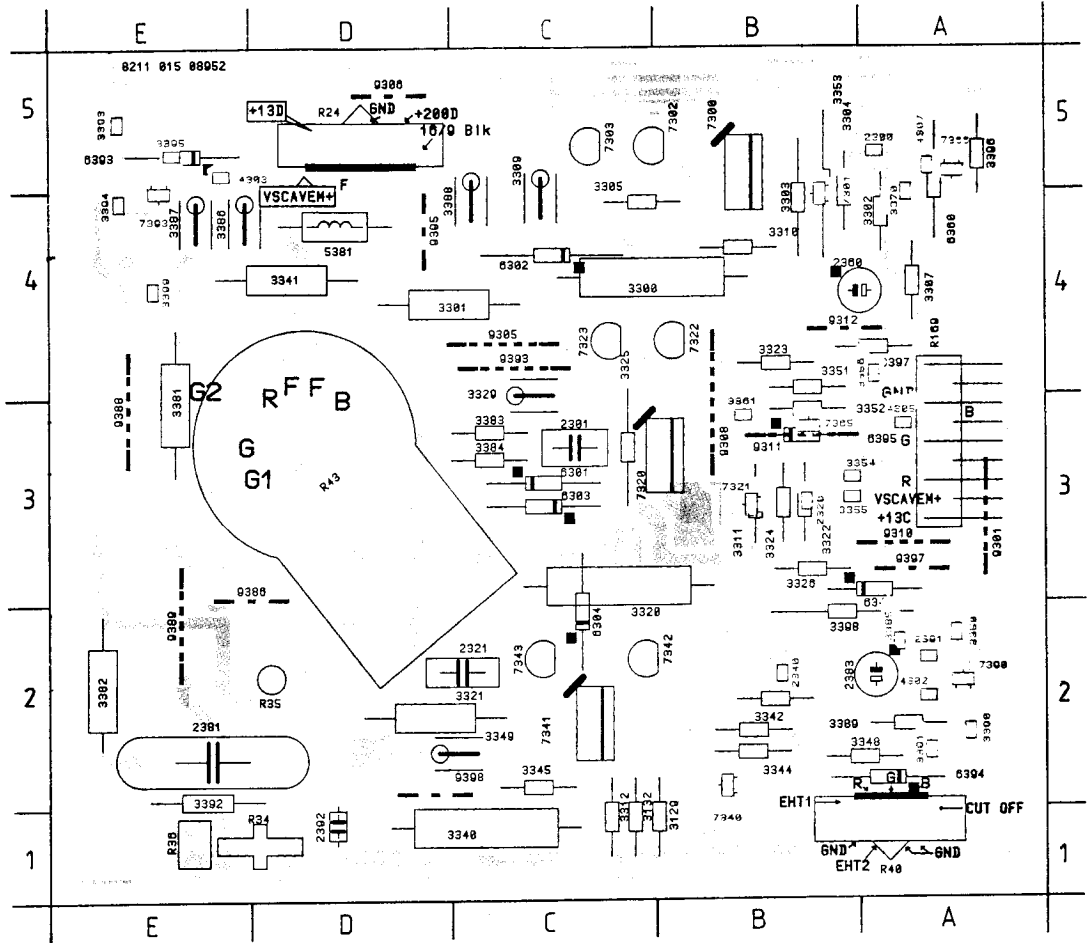
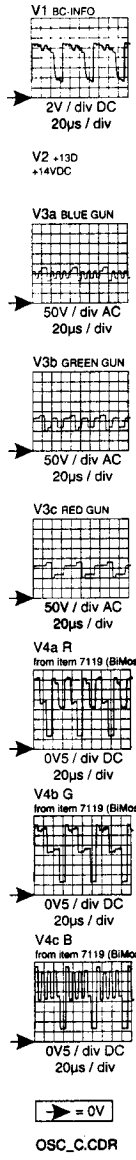

R34	D1	2360	A4	3305	B4	3326	B3	3352	B3	3386	D4	3398	A2	6360	A4	7340	B2*	9310	A3
R35	D2	2381	E2	3307	A4	3329	C3	3353	B4	3387	E4	3399	E4*	6393	E5	7341	C2	9311	B3
R36	E1	2383	A2	3309	C4	3340	C1	3354	A3*	3388	C4	4302	A2*	6394	A2	7342	B2	9312	A4
R40	A1	2391	A2*	3310	B4	3341	D4	3355	A3*	3389	A2	4303	E4*	6395	B3	7343	C2	9386	D2
R43	D3	2392	D1	3311	B3	3342	B2	3356	A4*	3390	A2*	4305	A3*	7300	B4	7365	B3*	9388	E3
R169	A3	3129	B1	3312	C1	3343	B2	3361	B3*	3391	A2*	4307	A5*	7301	B4*	7366	A4*	9389	E2
1300	E3*	3132	C1	3320	C3	3344	B2	3370	A4*	3392	E2	5381	D4	7302	B5	7390	A2*	9393	C4
2300	A5*	3300	B4	3321	D2	3345	C2	3381	E3	3393	E5*	6301	C3	7303	C5	7393	E4*	9395	D4
2301	C3	3301	C4	3322	B3	3348	A2	3382	E2	3394	E4*	6302	C4	7320	B3	9301	A3	9397	A3
2320	B3*	3302	A4	3323	B4	3349	C2	3383	C3	3395	E5*	6303	C3	7321	B3*	9305	C4	9398	D2
2321	C2	3303	B4	3324	B3	3350	A2*	3384	C3	3396	A5	6304	C2	7322	B4	9306	D5	*	= SMD
2340	B2*	3304	A4	3325	C3	3351	B3	3385	A2*	3397	A4	6344	A3	7323	C4	9308	B3	component	

For Service Manuals Contact  
**MAURITRON TECHNICAL SERVICES**  
 8 Cherry Tree Rd, Chinnor  
 Oxon OX9 4QY  
 Tel:- 01844-351694 Fax:- 01844-352554  
 Email:- enquiries@mauritron.co.uk

# Audio module / Audio Modul / Module audio

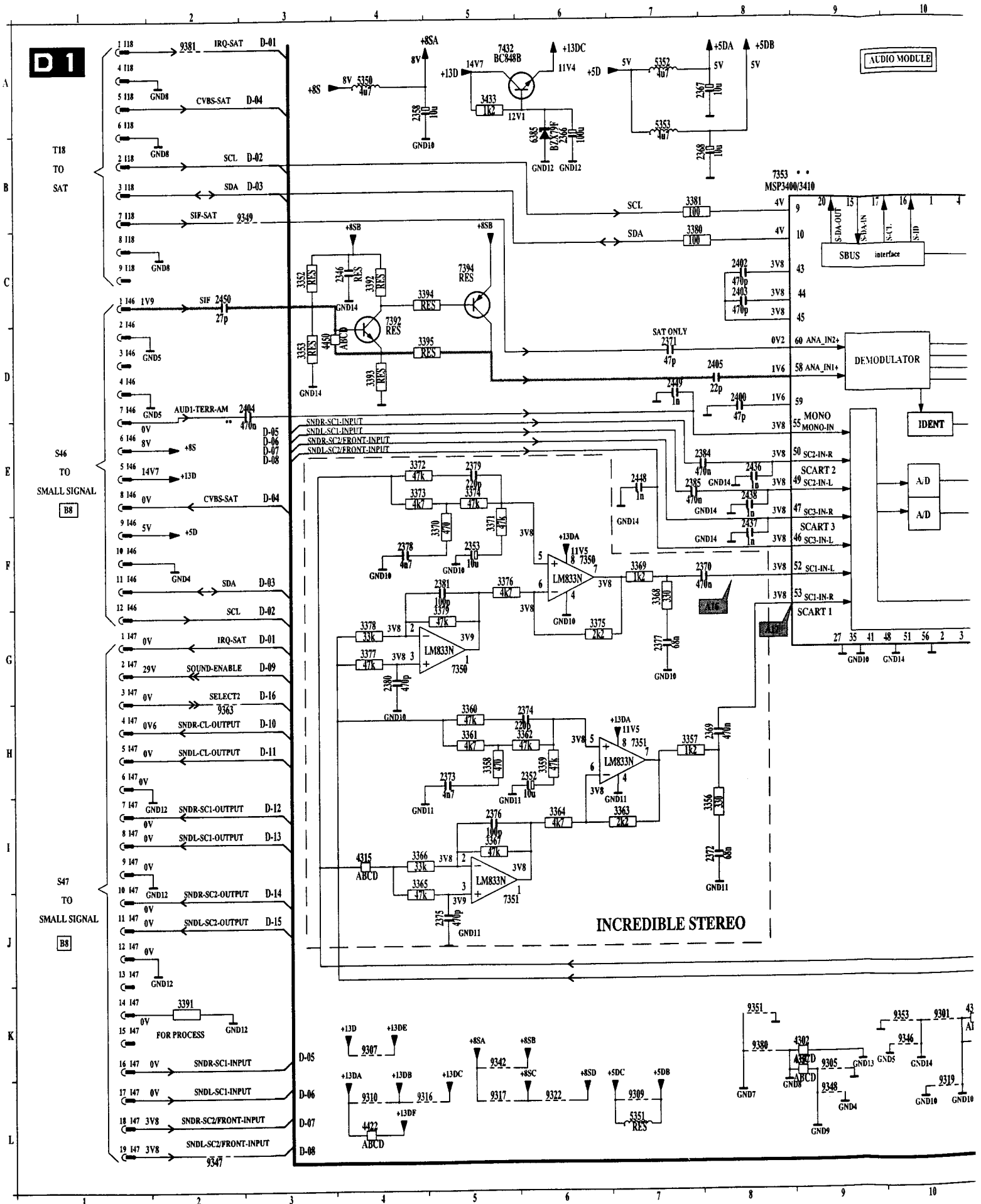

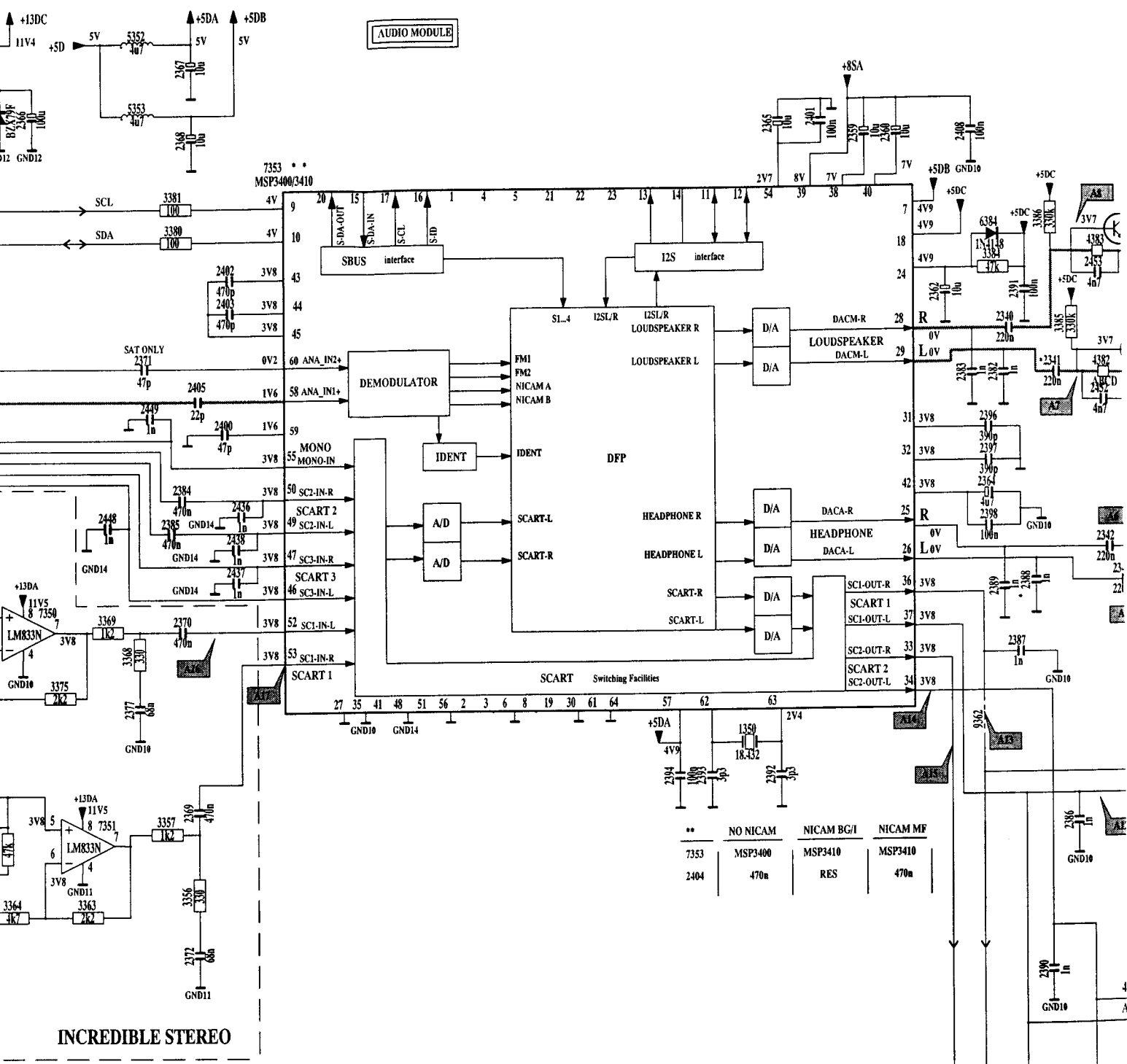

**AUDIO MODULE**

**INCREDIBLE STEREO**

	NO NICAM	NICAM BG/1	NICAM MF
7353	MSP3400	MSP3410	MSP3410
2404	470n	RES	470n

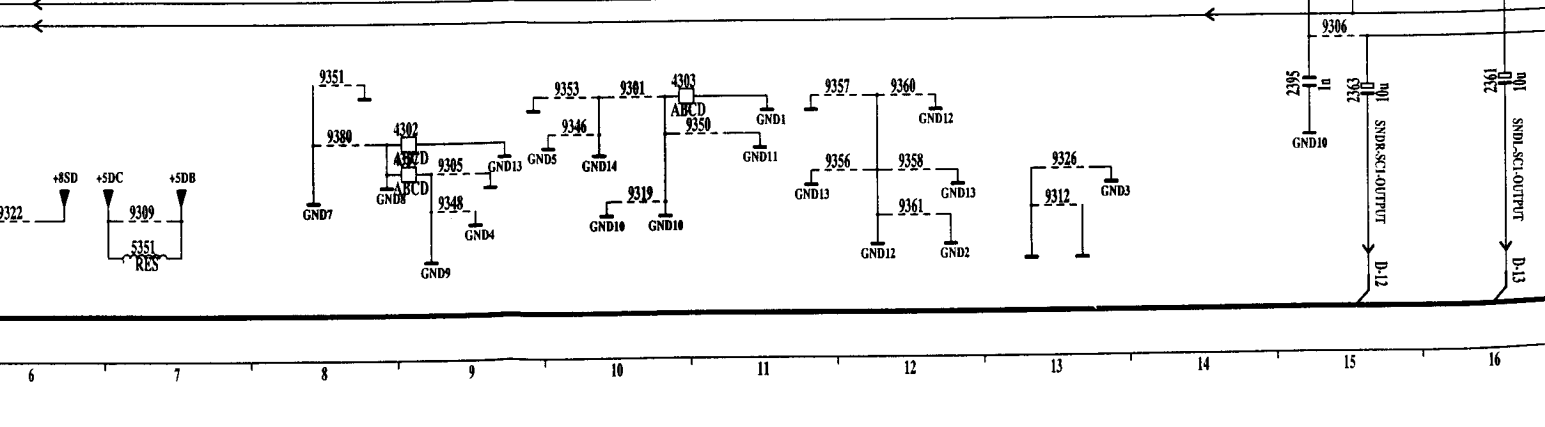

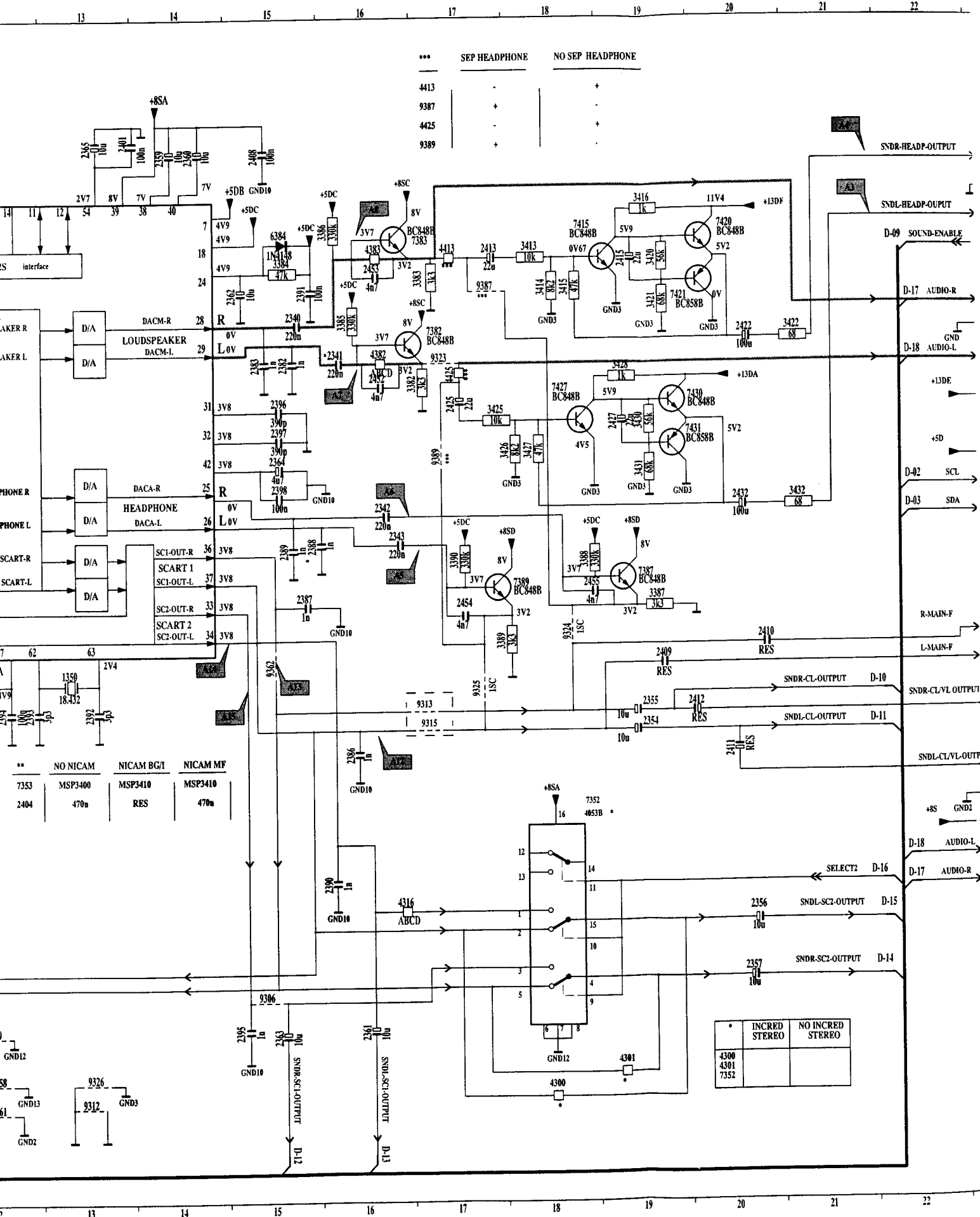

	SEP HEADPHONE	NO SEP HEADPHONE
4413	-	+
9387	+	-
4425	-	+
9389	+	-

**	NO NICAM	NICAM BGI	NICAM MF
7353	MSP3400	MSP3410	MSP3410
2404	470n	RES	470n

	INCRD STEREO	NO INCRD STEREO
4300		
4301		
7352		

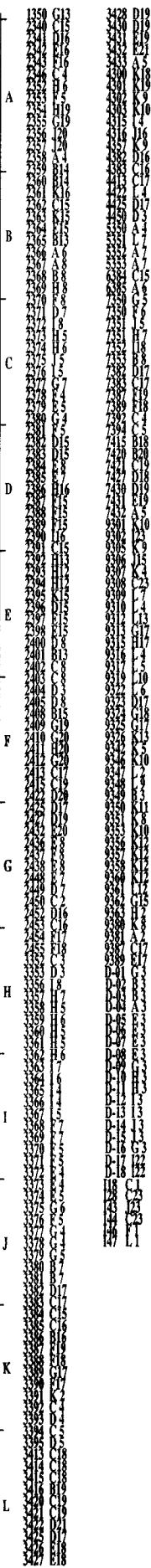
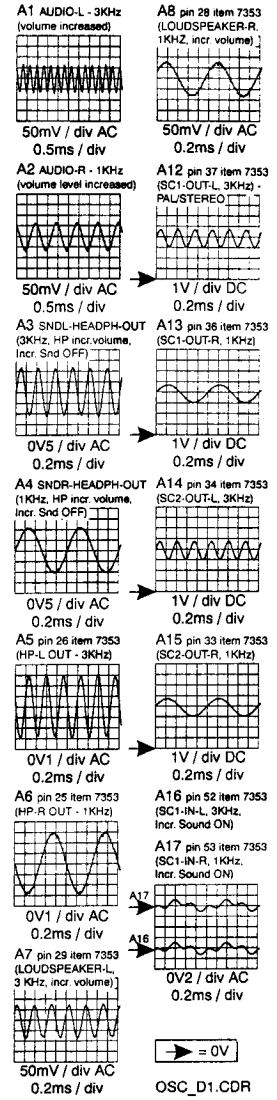
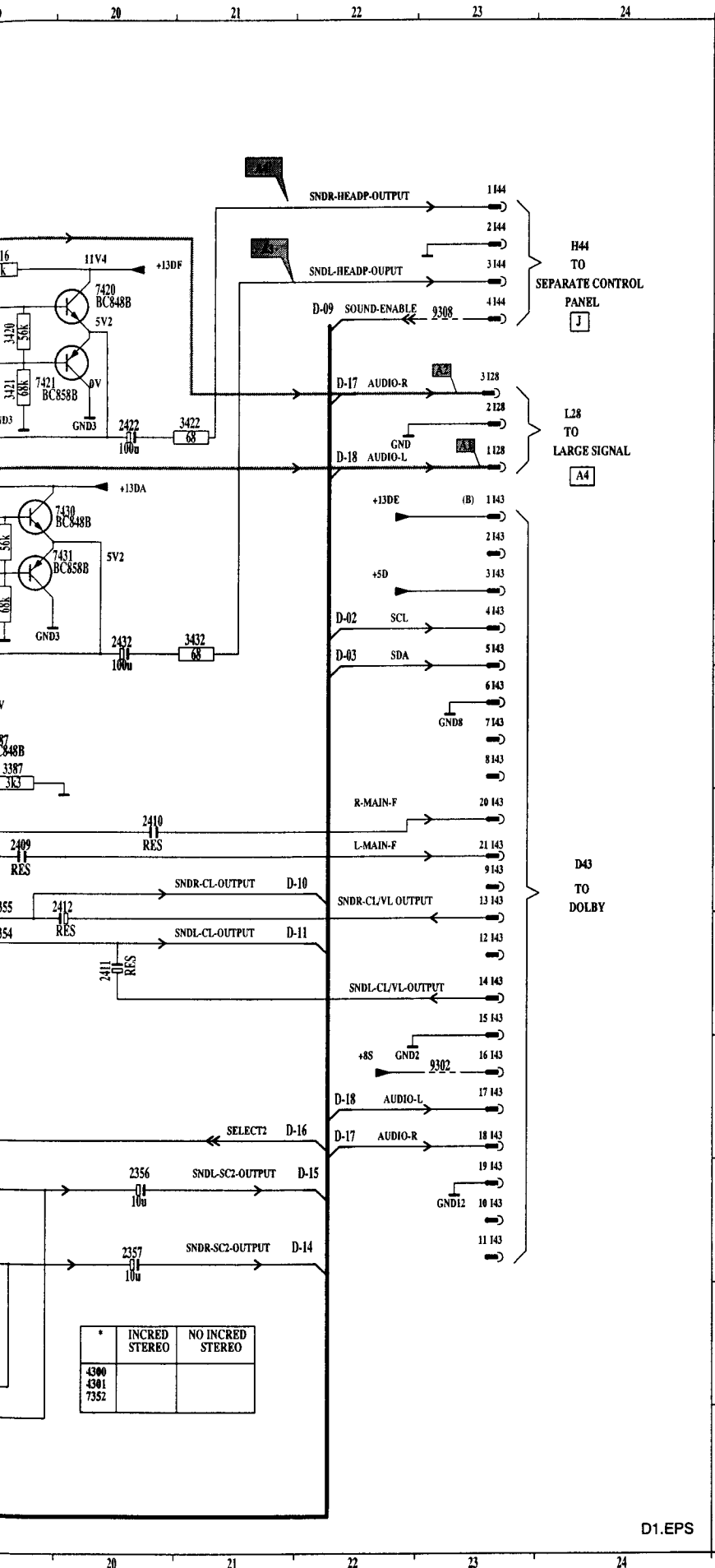





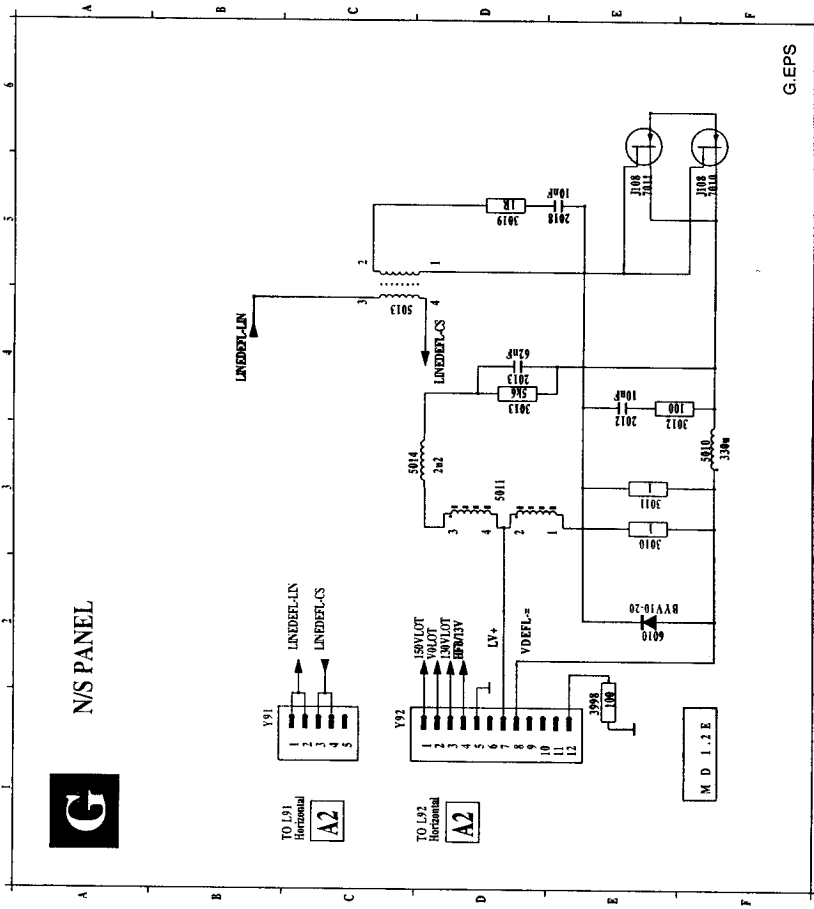

- 3013 E1
- 3013 D4
- 3018 E5
- 3019 E3
- 3019 E4
- 3019 E5
- 3019 E6
- 3019 E7
- 3019 E8
- 3019 E9
- 3019 E10
- 3019 E11
- 3019 E12
- 3019 E13
- 3019 E14
- 3019 E15
- 3019 E16
- 3019 E17
- 3019 E18
- 3019 E19
- 3019 E20
- 3019 E21
- 3019 E22
- 3019 E23
- 3019 E24
- 3019 E25
- 3019 E26
- 3019 E27
- 3019 E28
- 3019 E29
- 3019 E30
- 3019 E31
- 3019 E32
- 3019 E33
- 3019 E34
- 3019 E35
- 3019 E36
- 3019 E37
- 3019 E38
- 3019 E39
- 3019 E40
- 3019 E41
- 3019 E42
- 3019 E43
- 3019 E44
- 3019 E45
- 3019 E46
- 3019 E47
- 3019 E48
- 3019 E49
- 3019 E50
- 3019 E51
- 3019 E52
- 3019 E53
- 3019 E54
- 3019 E55
- 3019 E56
- 3019 E57
- 3019 E58
- 3019 E59
- 3019 E60
- 3019 E61
- 3019 E62
- 3019 E63
- 3019 E64
- 3019 E65
- 3019 E66
- 3019 E67
- 3019 E68
- 3019 E69
- 3019 E70
- 3019 E71
- 3019 E72
- 3019 E73
- 3019 E74
- 3019 E75
- 3019 E76
- 3019 E77
- 3019 E78
- 3019 E79
- 3019 E80
- 3019 E81
- 3019 E82
- 3019 E83
- 3019 E84
- 3019 E85
- 3019 E86
- 3019 E87
- 3019 E88
- 3019 E89
- 3019 E90
- 3019 E91
- 3019 E92
- 3019 E93
- 3019 E94
- 3019 E95
- 3019 E96
- 3019 E97
- 3019 E98
- 3019 E99
- 3019 E100

N/S PANEL / N/S PLATINE / PLATINE N/S

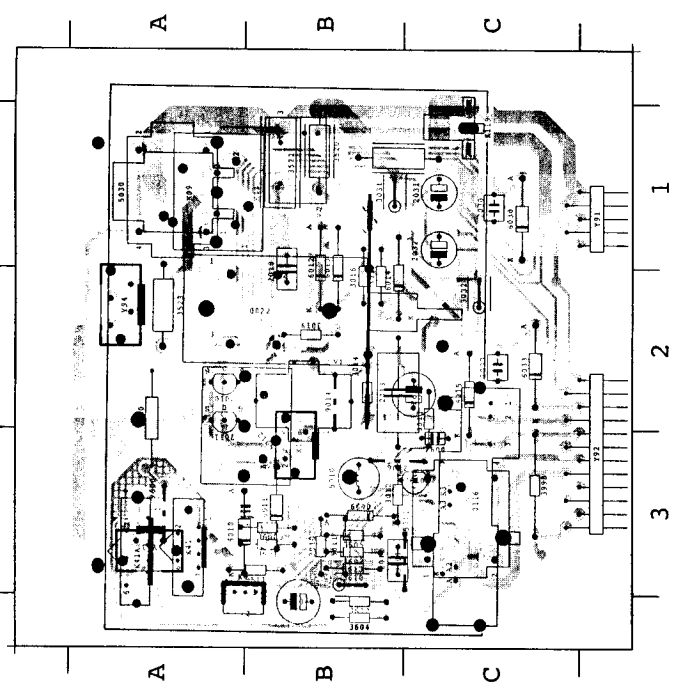

CTI/BLACK STRETCH PANEL / CTI/BLACK STRETCH PLATINE / PLATINE CTI/BLACK STRETCH

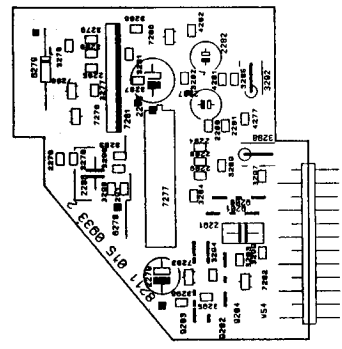

For Service Manuals Contact  
**MAURITRON TECHNICAL SERVICES**  
 8 Cherry Tree Rd, Chinnor  
 Oxon OX9 4QY  
 Tel: 01844-351694 Fax: 01844-352554  
 Email: enquiries@mauritron.co.uk

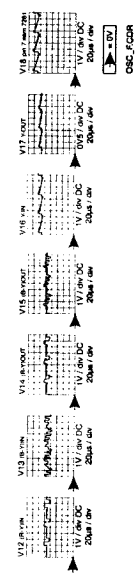





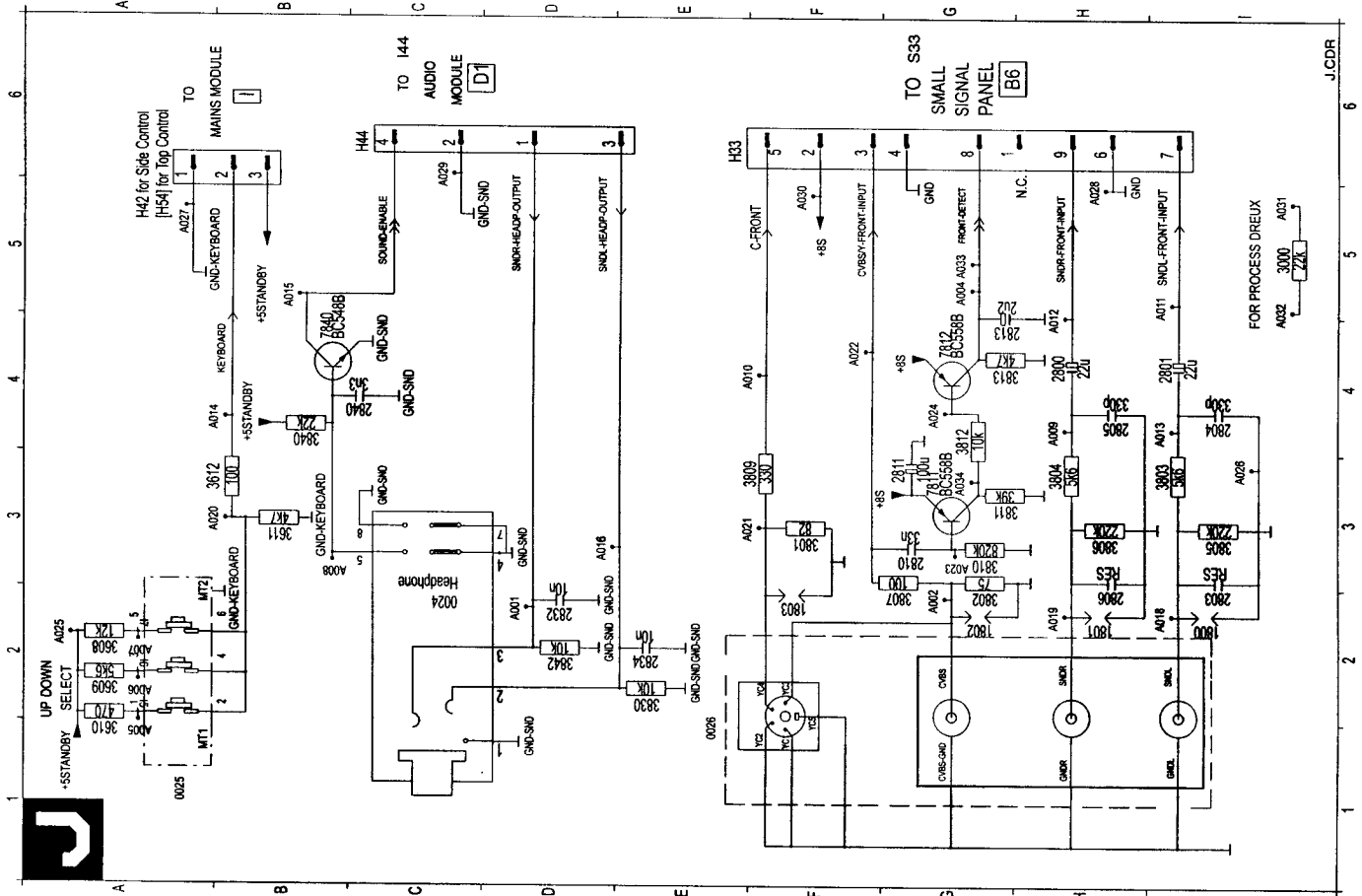

Styling with side Input/Output and top control

SIDE I/O PANEL

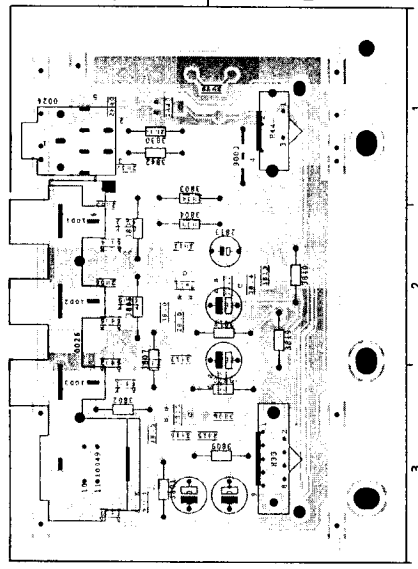

TOP CONTROL PANEL

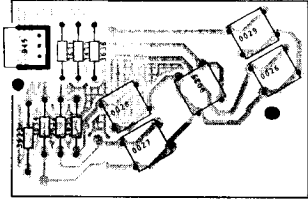

Styling with side control + side Input/Output

SIDE CONTROL + I/O PANEL

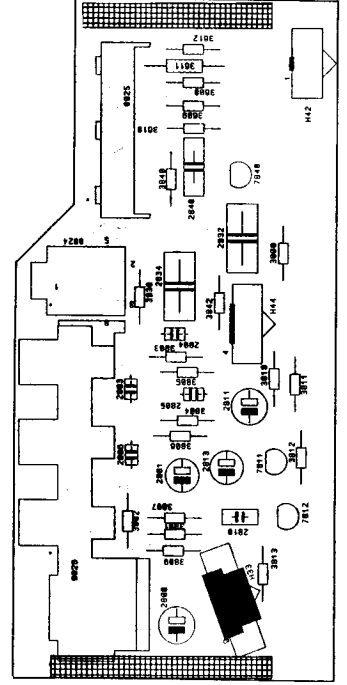

For Service Manuals Contact  
 MAURITRON TECHNICAL SERVICES  
 8 Cherry Tree Rd, Chinnor  
 Oxon OX9 4QY  
 Tel:- 01844-351694 Fax:- 01844-352554  
 Email:- enquiries@mauritron.co.uk

General: the Service Default Mode (SDM) and Service Alignment Mode (SAM) are described in chapter 6.

**Alignment conditions:**

- All electrical adjustments should be performed under the following conditions:
  - Power supply voltage: 240V ± 10%, 50Hz ± 5%
  - Warm-up time: ~ 10 minutes
  - The voltages and oscillograms are measured in relation to the tuner earth.
  - Test probe: Ri > 10MΩ; Ci < 2,5 pF.

### 8.1 Adjustments on the large signal panel

#### 8.1.1 95V/140V supply voltage

For 21" TV-sets

Connect a voltmeter to the cathode of D6567. With the aid of R3532 adjust the power supply voltage to 95V ± 0,5V.

For sets 21"

Connect a voltmeter to the cathode of D6567. With the aid of R3559 adjust the power supply voltage to 140V ± 1V.

#### 8.1.2 Vg2 adjustment

Connect a pattern generator displaying a full black picture. Switch the TV-set to the service default mode (see chapter 6). Connect an oscilloscope to the picture tube cathodes for red, green and blue (pins 6, 8 and 11 of the picture tube socket). Set the oscilloscope to DC, 50V/div and 2 ms/div. Measure the DC level of the measuring pulses at the end of the frameblanking (see fig. 8.1). Using the Vg2 potentiometer on the line transformer (bottom potentiometer) the measuring pulse with the highest level must be set to +160V ± 2V.

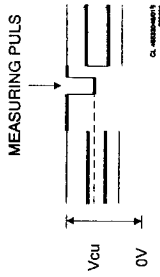

Figure 8.1

#### 8.1.3 Focusing

Is aligned using the focuspentiometer on the line transformer (top potentiometer).

### 8.2 Alignments on the small signal panel

#### 8.2.1 40.4 MHz IF filter (only for sets with SECAM LL' reception)

Using a signal generator (e.g. PM5326) and a capacitor of 5,6 pF supply a 40.4 MHz signal to pin 17 of the tuner. Connect an oscilloscope to pin 1 of filter 1016. Switch on the set and select in the installation menu MANUAL; SYSTEM EUR.W. Align coil L5117 for maximum DC output voltage.

#### 8.2.2 AFC

Switch the set to service default mode (see chapter 6). Using a pattern generator (e.g. PM5518) supply a signal on a frequency of 475,25 MHz. Align coil L5114 for optimal picture quality.

#### 8.2.3 Picture demodulator (only for sets with SECAM LL' reception)

Using a signal generator (e.g. PM5326) supply a 32,95MHz signal via a 5,6 pF capacitor to pin 17 of the tuner. Align the signal level of the generator so that the DC-voltage on pin 5 of the tuner is 5V. Switch on the set and select in the installation menu MANUAL; SYSTEM FRANCE. Align capacitor C2106 for minimal voltage on pin 5 of the tuner.

#### 8.2.4 RF-AGC

If the signal of a strong local transmitter is distorted, align the value for AX (AGC crossover) in the service menu (see chapter 6) until the picture is no longer distorted.

#### 8.2.5 Audio demodulator (Not for sets with LL' and NICAM reception possibility)

Using a signal generator (e.g. PM5326) supply a 38,9MHz signal via a 5,6 pF capacitor to pin 17 of the tuner. Connect an oscilloscope (2ms/div) to pin 12 of IC7033 (TDA3845). Align coil L5030 for minimal amplitude.

### 8.3 Picture tube alignments

#### 8.3.1 Whitebalance

Connect a pattern generator and select a white picture. Set contrast to maximum (63) for 21" or to 40 for 21" tv-sets. Use the ↑/↓ keys to select an alignment and the ←/→ keys to change the value. Set GD to 50, RD to 57 and BD to 45. If necessary change the settings for RD and BD for a correct white balance.

### 8.3.2 Geometry adjustments (for software versions M12COx-3.x and M12BAx-x.x)

Connect a pattern generator and select a geometry pattern (signal at 475,25 MHz)

- Switch to the Service Default Mode, then to the Service Alignment Mode.
- Select the desired alignment with the ↑/↓ keys.
- Change the selected alignment with the ←/→ keys.
- A value between 0 and 63 can be selected.
- Changed values are stored immediately.

**Vertical**

- VP: Vertical Shift  
Set this for the correct vertical position.
- VA: Picture height  
Set this for the correct picture height.
- VL: Vertical linearity  
Set this so that the vertical centre of the picture is at the centre of the tube.
- VS: Vertical S-correction  
Set this so that the height of the squares in the top of the picture equal the height in the bottom of the picture.

**Horizontal**

- HD: Horizontal shift.  
Set this so that the horizontal centre of the picture is on the centre of the tube.

For sets with a screen size larger than 21", the following alignments can be done as well. For 21" sets these alignments have no function.

- HW: East-west width  
Align the picture width with this.
- HP: East-west parabola correction  
Set this so that the vertical lines at the sides of the screen are straight.
- HC: East-west corner-correction.  
Set this so that the vertical lines are straight in the corners.
- HT: Trapezium correction  
Set this so that the vertical lines are as vertical as possible.

Adjustments for 16:9 sets (reserved)  
16 = N \*3 tube (options SS, D1, D2, D3 and D4 not available (blue))  
16 = Y 16:9 tube (options SS, D1, D2, D3 and D4 available)

### 8.4 Options

- E2: Number of Euro/Scart connectors (options N or Y)  
N 1 Euro/Scart connector present  
Y 2 Euro/Scart connectors present
- UO: Tuner type  
N UHF/VHF tuner (item 1000 is UV916S)  
Y UHF tuner (item 1000 is UV944S)  
Used in the United Kingdom (05 sets)
- LL: Nicam L (options N or Y)  
N Nicam L not present  
Y Nicam L present (Nicam L panel required and item 7353 is MSP3410)
- NI: Nicam (stereo) sound (options N or Y)  
N Only 2CS stereo, no Nicam (item 7353 is MSP3400)
- TT: Teletext (options N or Y)  
Y Teletext present  
N No Teletext present  
(Eastern Europe) teletext type (options N or Y)
- ET: 2CS and Nicam stereo (item 7353 is MSP3410)  
Y No Eastern Europe teletext (58 sets)  
N Eastern Europe teletext (58 sets)
- 14: 14:9 Picture format supported by 4:3 tube (options N or Y)  
N Not supported  
Y Supported
- HI: Histogram (not with software version M12BAx-x.x)  
N No Histogram present (options VG, VA and NL not available (blue))  
Y Histogram present (options VG, VA and NL available)
- M2: MD1.1E or MD1.2E chassis (only with software version M12BAx-x.x)  
N MD1.1E chassis  
Y MD1.2E chassis

Large signal panel / Groß-Signal Platine / Platine forts signaux

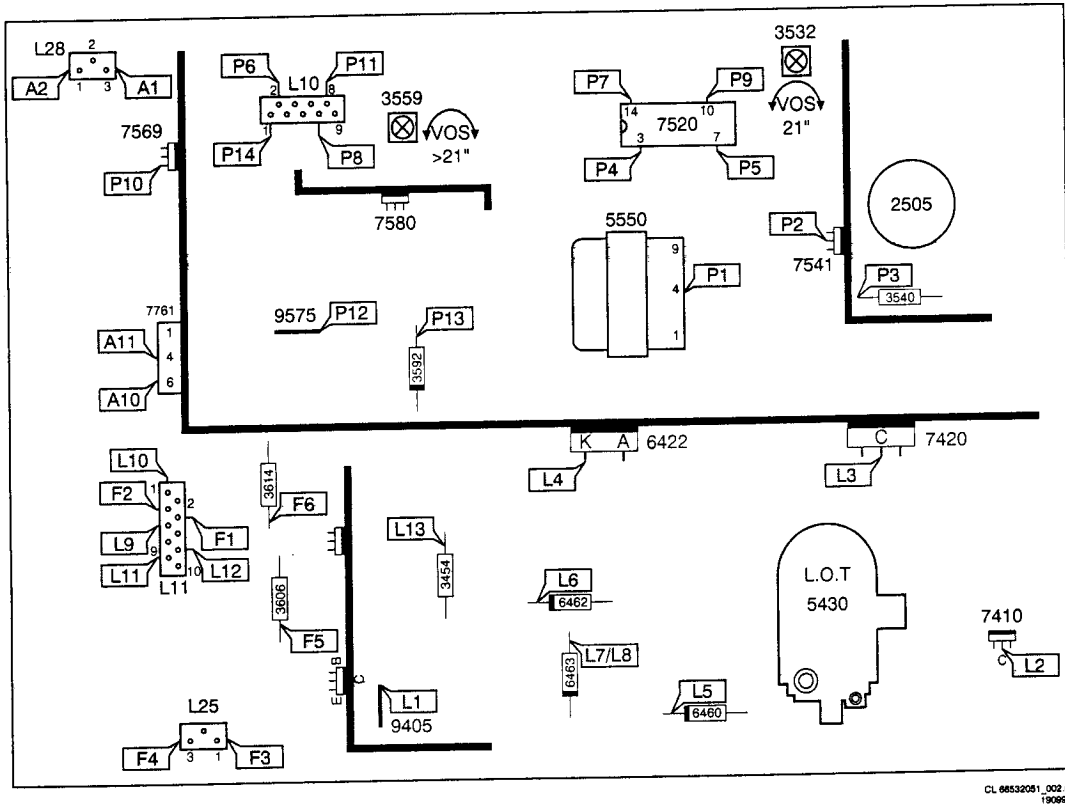

CL 66532061\_002.ni  
190996

Small signal panel / Klein-Signal Platine / Platine petits signaux

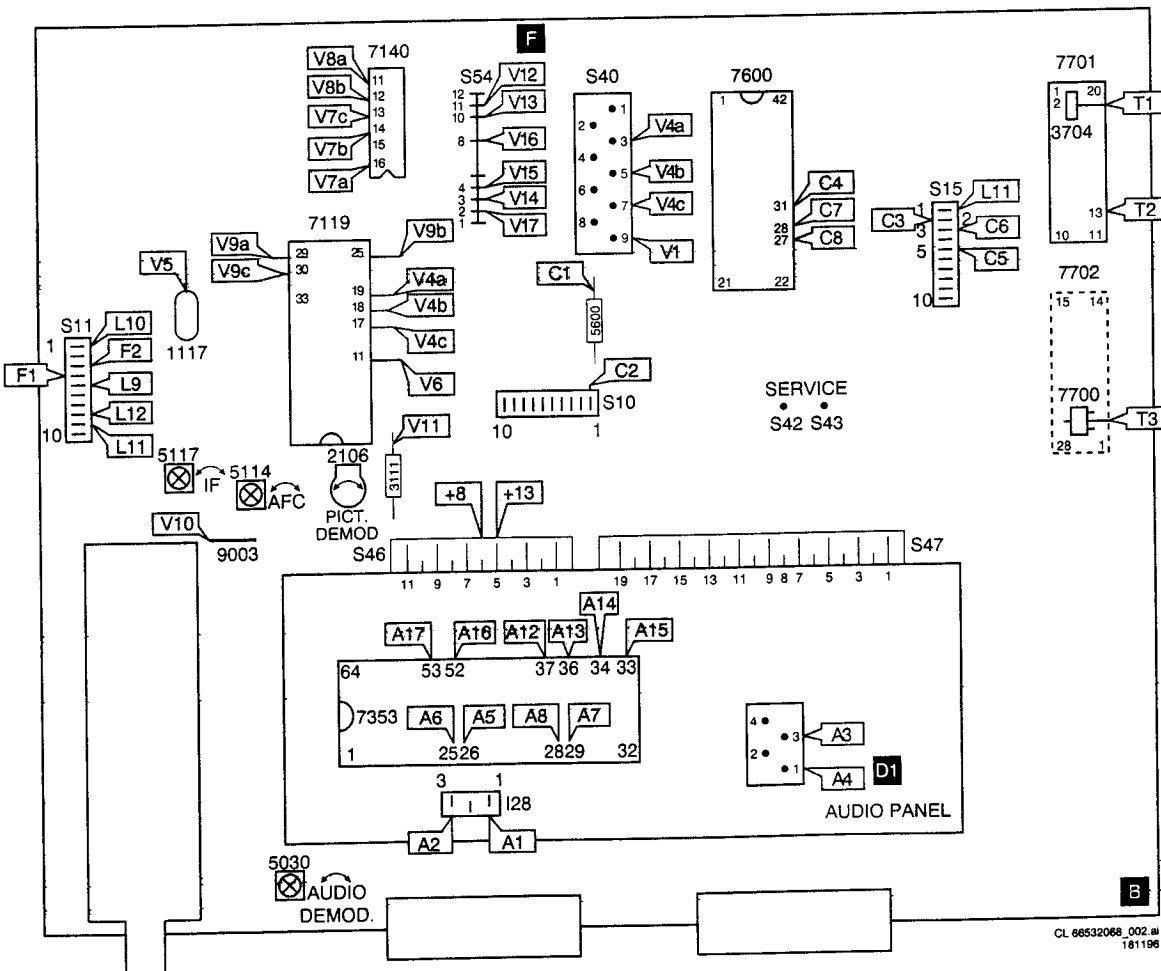

CL 66532068\_002.ni  
181196

**Remote control keys**

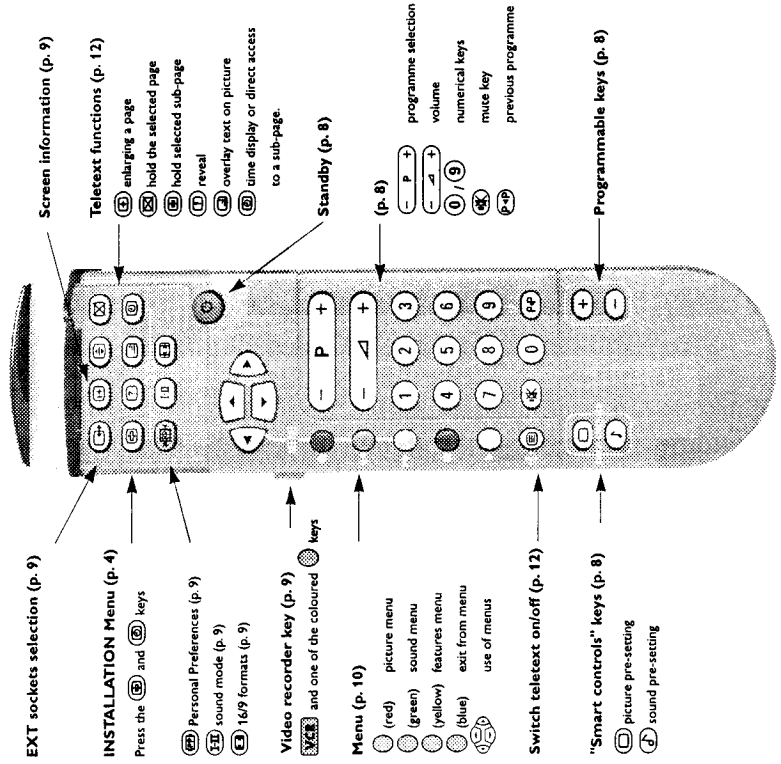

**The keys on the TV set**

The television has 3 keys: MENU, - and +. These keys are located on the top, front or side of the set, (if on the front or side of the set they may be concealed by a flap). The MENU key is used to select the function to be altered. The - and + keys are used to select programmes or modify the selected MENU item.

**Installation Menu**

This Menu enables you to tune in the channels on the TV set.

**To call up the INSTALLATION menu:**

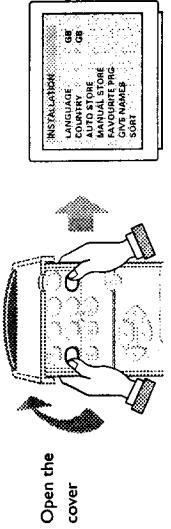

Press the **Ⓜ** and **Ⓜ** keys at the same time. The INSTALLATION menu appears on the screen.

If the menu display is not stable, press the **Ⓜ** key.

**To use the menus:**

These 4 keys allow you to move around in the menus, make adjustments and access the sub-menus.

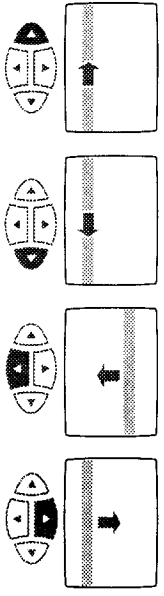

**To exit from the menus**

Press the blue **Ⓜ** key.

**Selecting the menu language**

From the INSTALLATION menu:  
 ♦ Select the LANGUAGE adjustment using the **Ⓜ** keys.  
 ♦ Select the language you wish to use by means of the **Ⓜ** or **Ⓜ** keys.  
 × The text for all the menus will appear in the language you have chosen.

**Selecting the country**

♦ Select the COUNTRY adjustment using the **Ⓜ** keys  
 ♦ Select your country using the **Ⓜ** or **Ⓜ** keys (GB for Great Britain).  
 Warning: it is essential for correct channel tuning that these two adjustments are set correctly.

For Service Manuals Contact  
**MAURITRON TECHNICAL SERVICES**  
 8 Cherry Tree Rd, Chinnor  
 Oxon OX9 4QY  
 Tel:- 01844-351694 Fax:- 01844-352554  
 Email:- enquiries@mauritron.co.uk

### Tuning-in the TV channels

There are two ways the television can be tuned in : automatic store or manual store (tuning - in channel by channel).

#### Automatic store

- From the INSTALLATION menu (Ⓜ and Ⓜ keys) (after ensuring LANGUAGE and COUNTRY have been set correctly)
- Select AUTO STORE (Ⓜ and Ⓜ keys) and press
- The AUTO STORE menu appears. Searching begins. The message SEARCHING PLEASE WAIT appears on the screen.
- The TV set searches through the complete frequency range in your local region and stores all the programmes it finds. The search operation takes a few minutes. When the search is complete, the INSTALLATION menu reappears automatically.
- This TV set is equipped with an Easy Tune system which automatically sorts the programmes by name.
- If the transmitter emits the correct signal, the programmes are correctly numbered.

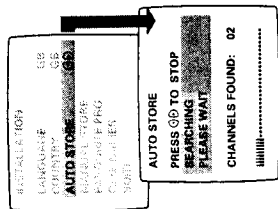

In certain cases, the system may ask you to indicate your local region using keys

Ⓜ to Ⓜ

- If no signal is emitted, the programmes will be numbered in descending order starting from 99, 98, 97, ... Should this occur, the SORT menu should be used to re-number the programmes.

If no picture is found, refer to the chapter entitled "Tips" (page 17).

#### Sort

- This menu allows you to re-number the programmes in the order you prefer.
- Select SORT (Ⓜ and Ⓜ keys) and press
- The SORT menu appears.
- The menu provides a list of all the programme numbers with their names (where provided), or frequencies or channels.

- Using the Ⓜ and Ⓜ keys, select the programme to be re-numbered. If, for example, you want to re-number programme 96 as 2: Select 96 using Ⓜ and Ⓜ keys (or type Ⓜ and Ⓜ).  
The number chosen (96) will appear in blue in the list.
- Press the key to enter.
- A yellow rectangle appears on the name of the programme (or on its frequency or channel).  
Enter the new number using keys Ⓜ to Ⓜ.

In our example, type Ⓜ. Programme 02 appears.

The number (02) appears in blue in the list.

- Press the key to enter ( can be used to cancel).

The exchange of numbers is now complete. In our example, programme No. 96 has become No. 02 (and programme No. 02 has become No. 96). Repeat this operation for other programmes you wish to re-number

#### To exit from the menu

- Press the blue key.

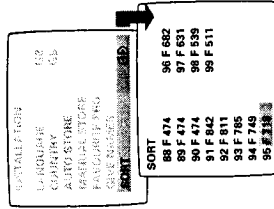

### Manual store

- From the INSTALLATION menu (Ⓜ and Ⓜ keys).
- Select MANUAL STORE (Ⓜ and Ⓜ keys) and press
- The MANUAL STORE menu appears.

#### 1 Select channel or frequency mode

- For certain countries this adjustment is not available.
- Select CHANNEL/FREQUENCY (Ⓜ and Ⓜ).
- Use the Ⓜ keys to select tuning mode. FREQ. (frequency search) or CHAN.C and CHAN.S (channel search if you know the channel numbers on which the programmes are broadcast).

#### 2 Selecting the TV system

- Select SYSTEM (Ⓜ and Ⓜ).
- Use Ⓜ to select EUROPE, EUR, W, EUR, E, UK or FRANCE (according to model).
- Selecting EUROPE guarantees automatic detection, with the exception of transmissions from France (standard LL; select FRANCE) or in certain cases of poor reception where EUR, W (BG), EUR, E (DK) or UK (I) should be selected.

For more information see glossary on p. 18

#### 3 Search

- Select SEARCH (Ⓜ and Ⓜ) and press
- The search begins. As soon as a programme is found, the search will stop. Go to section 4.
- If you know the frequency (or the channel) of the programme you wish to receive, you can enter its number in directly using keys numbered Ⓜ to Ⓜ.

If no picture is found, refer to "Tips" chapter (page 17).  
If you want to return the search, press again.

#### Fine tuning

- If reception is not satisfactory, you can use the fine tuning function.
- Select FINE TUNE (Ⓜ and Ⓜ).
- Hold down the Ⓜ keys to adjust.

#### 4 Programme number

- Select PRG NUMBER (Ⓜ and Ⓜ)
- Use the Ⓜ keys or the Ⓜ to Ⓜ keys to enter the required number.

#### 5 Store

- Select STORE (Ⓜ and Ⓜ) and press
- The OK message appears. The programme and its name (if it has one) are stored.

repeat 3, 4, 5 for each programme to be stored.

#### To exit from the menu:

- Press the blue key.

## Favourite Programmes

This menu allows you to choose which programmes can be accessed using the **FAV** key on the remote control.

From the **INSTALLATION** menu:

- Select **FAVOURITE PRG** (**FAV** key) and press
- ▶ The **FAVOURITE PRG** menu appears. All programmes found during the search are automatically included in the menu and appear in green.
- Use the **UP**/**DOWN** keys to select any programme you wish to remove from the list of favourites.
- Press **ENTER** to de-activate (or activate) a programme.
- ▶ The de-activated programmes appear in white, the activated programmes appear in green.

Only the programmes and EXT sockets that are displayed in green in this menu can be accessed using the **FAV** key.

*Warning:* If all programmes are de-activated the **FAV** key will cease to function.

### To exit from the menu:

- Press the blue **OK** key.

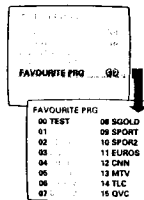

## Programme names

This menu allows you to name and modify names for programmes and EXT sockets.

From the **INSTALLATION** menu:

- Select **GIVE NAMES** (**NAME** key) and press
- ▶ The **GIVE NAMES** menu appears with the list of programmes found automatically during installation.
- Certain programmes may not be named (the signal needed for identification is not always transmitted) or may be inappropriately named (only 5 characters are displayed).
- Use the **FAV** key to select the required programme.
- Use the **UP**/**DOWN** keys to move to the area in which the programme name appears (up to 5 characters)
- ▶ A yellow rectangle appears in the chosen area.
- Use the **UP**/**DOWN** keys to select the character to be modified.
- Use the **LEFT**/**RIGHT** keys to modify the selected character.
- Use the **LEFT**/**RIGHT** keys to move around in the next programme.

### To exit from the INSTALLATION menu:

- Press the blue **OK** key twice.

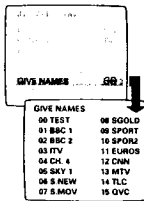

## Using the remote control

Press:	Result:
<b>STANDBY</b>	The TV set is switched off and the red indicator lights up. To switch the TV set on again, press <b>POWER</b> or keys <b>0</b> to <b>9</b> . <i>For further information, see "Tips" (p. 17)</i>
<b>SELECTING TV PROGRAMMES</b>	Move up or down a programme. <i>N.B. Only programmes activated in the FAVOURITE PRGS menu can be accessed (see p. 7).</i>
<b>VOLUME</b>	The volume is adjusted.
<b>NUMERICAL KEYS</b>	Choose a programme. The number (and name if it exists) appears on the screen. For a 2 figure number, the second figure must be entered before the dash disappears.
<b>MUTE KEY</b>	Disables or enables the sound.
<b>PREVIOUS PROGRAMME</b>	Return to the last programme watched.
<b>"SMART CONTROLS" KEYS</b>	To access the presets of the TV set. Picture presets: ( <b>PICTURE</b> key). Each time it is pressed, a different picture preset is selected: RICH, SOFT, NATURAL or MANUAL. Sound presets: ( <b>SOUND</b> key). Each time it is pressed, a different sound preset is selected: SPEECH, MUSIC, THEATRE or MANUAL. The values corresponding to these presets are given in the PICTURE and SOUND menus (see p. 10).
<b>PROGRAMMABLE KEYS</b>	These allow direct access to any adjustment made in the PICTURE and SOUND menu (see p. 10). To program the keys: If, for example, you wished to gain direct access to the BRIGHTNESS adjustment. Display the PICTURE menu (red <b>PICTURE</b> key) and select BRIGHTNESS ( <b>BRIGHTNESS</b> key). Use keys <b>UP</b> and <b>DOWN</b> to adjust, rather than the <b>UP</b> / <b>DOWN</b> keys. The keys are now programmed. Exit from the menu (blue <b>OK</b> key). Press <b>PICTURE</b> and <b>BRIGHTNESS</b> again. This will give you direct access to the brightness adjustment. Repeat for any other adjustment you may wish to make.



## Other functions

Press:	Result:
<b>EXT</b>	Select EXT sockets Pressing this key selects E1 (EXT1), E2 (EXT2) and E2 Y/C in turn (see p. 15).
<b>SCREEN</b>	Screen information Press for 3 seconds to activate/de-activate the continuous display of the programme number. Press briefly to display the number, name (if there is one), sound mode and time remaining (see SLEEPTIMER p. 11).
<b>TIME</b>	Time display The time is displayed in the top right-hand corner of the screen. <i>This function only exists if the programme broadcasts teletext.</i>
<b>PERSONAL PREFERENCES</b>	Personal Preferences Restores the settings made in the FEATURES menu (see p. 11)
<b>SOUND MODE</b>	Sound mode Pressing this key allows you to switch from STEREO to MONO sound (in case of stereo transmission), or to choose between language I or language II (in case of bilingual transmissions). For TV sets fitted with NICAM reception, the DIGITAL message appears when a NICAM broadcast is received. The <b>STEREO</b> key allows you to switch from DIGITAL STEREO to MONO or, for bilingual transmissions, to choose between DIGITAL I, DIGITAL II or MONO.
<b>16/9 FORMATS</b>	16/9 Formats Movies and other programmes may be broadcast in a wide screen format. These may have an aspect ratio of 14/9 or 16/9, pressing this button vertically squeezes the picture to adapt the aspect ratio to that of the transmission. Pressing the button again returns the screen format to 4/3. <i>For more information, see glossary (p. 18).</i>
<b>VCR</b>	Video recorder keys Press the <b>VCR</b> key and one of the following keys simultaneously: <ul style="list-style-type: none"> <li>record,</li> <li>rewind,</li> <li>fast forward,</li> <li>stop,</li> <li>play,</li> <li>programming (on certain models),</li> <li>1- or 2- digit programmes, programme selection,</li> <li>enter a programme number,</li> <li>standby</li> </ul> <i>These keys function with video recorders in our range and with all models which use the RCS signalling standard.</i>

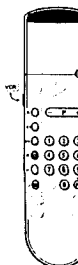
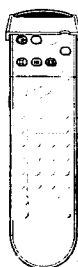

## Using the menus

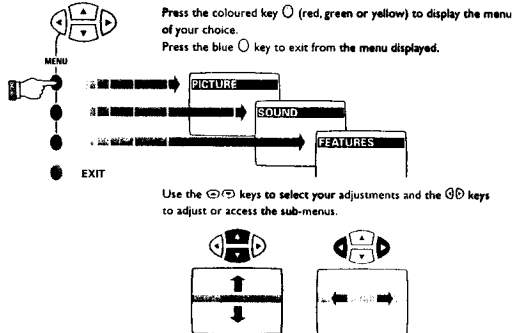

### Picture

- Display **PICTURE** menu (red **PICTURE** key).
- Use **UP**/**DOWN** to select the adjustments and **LEFT**/**RIGHT** to adjust.
- ▶ You can now access the adjustments: BRIGHTNESS, COLOUR, CONTRAST, SHARPNESS and TINT. Sharpness adjusts the clarity of the picture. Tint adjusts the colour temperature of the picture from "cool" (blue white) to "warm" (red white).
- **NOISE REDUCT.** Useful in case of poor reception to reduce picture noise (snowy picture).
- **DYNAMIC CONTR.** (only on certain models) Automatically adapts the contrast to suit the picture content.  
*For picture adjustment see also "Tips" (p. 17).*



### Sound

- Display **SOUND** menu (green **SOUND** key).
- ▶ You can now access the BALANCE, TREBLE, BASS, HEADPHONES adjustments and activate the INCR. SOUND option. INCR. SOUND enhances the stereo effect, giving the impression that the speakers are positioned further apart. For mono transmissions a stereo effect is created.
- **HEADPHONES:** Allows you to adjust the headphones volume independently from the loud-speakers on the TV set.

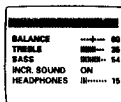

### To exit from the menu:

- Press the blue **OK** key.

Directions for use

# Directions for use

## Features

### Child Lock

The child lock function is an electronic lock which disables the keys on the TV set.

- Display the FEATURES menu (yellow key).
- Select CHILD LOCK () keys).
- Use keys to switch to ON.
- Switch off the TV set and remove the remote control. The television can no longer be used.
- ▶ The TV set can only be switched on using the remote control.
- To cancel: Return CHILD LOCK to OFF in the features menu.

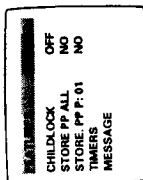

### Storing adjustments

This function allows you to store your own picture and sound adjustments. The adjustments are restored every time your set is switched on, or by pressing the green key on your remote control.

### General storing

First carry out your PICTURE and SOUND adjustments and adjust the volume ( key) and then:

- Display the FEATURES menu (yellow key).
- Select STORE PP ALL () keys) and press .
- ▶ The message OK appears. All the PICTURE and SOUND menu adjustments as well as the volume are stored.

### Storing adjustments for each programme

This function allows you to correct any differences in levels which may exist between TV channels and/or EXT sockets. It allows you to store BRIGHTNESS, COLOUR, SHARPNESS, NOISE REDUCT. and volume adjustments ( key).

Carry out desired corrections to settings for the programme (or EXT connection), and then:

- Display the FEATURES menu (yellow key).
- Select STORE PP P: \_\_\_ () keys) and press .
- ▶ The message OK appears. The adjustments are stored. Repeat for each programme that needs correcting.

## Programming

### Sleeptimer

- From the FEATURES menu (yellow key).
- Select PROGRAMMING () and press .
- ▶ The PROGRAMMING menu appears.
- Select SLEEPTIMER and use to enter the length of time after which the TV will switch to standby mode (up to 180 mins). Press the key to display the length of time remaining.
- To cancel: Switch SLEEPTIMER back to 0.

11

### Programmed Switch on

The following adjustments allow you to program the TV to automatically switch on with the programme of your choice.

- Select the adjustments using keys:
  - SET CLOCK: Use keys to or the keys.
- N.B.:* Every time the TV is switched on the clock is automatically updated on the basis of the teletext information in programme No. 1. If the TV set does not feature teletext, this update will not occur.
- START TIME: Use keys to or keys.
  - STOP TIME: Use keys to or keys.
  - PRG NUMBER: Use keys to or keys.

DAILY: Set this option to ON ( key) if you want the programming to apply every day.

TIMER ACTIVE Set this option to ON to activate the timer.

▶ Press the blue key to exit from menu.

If you now switch the TV set onto standby ( key), it will automatically switch on at the time programmed.

■ To cancel: Switch TIMER ACTIVE back to OFF.

*N.B.:* For programming to function correctly do not use the on/off key on the front of the TV set to switch off the TV.

The programmed switch on-off can be used together with the child lock function in order to limit the use of the TV set to a certain length of time.

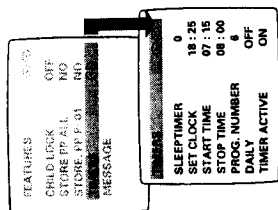

## Message

This menu allows you to leave a message which will appear on the screen when the TV is switched on (e.g.: "call me when you get home").

- From the FEATURES menu (yellow key).
  - Select MESSAGE () and press .
  - ▶ The MESSAGE menu appears. Select the adjustments using keys:
  - CHANGE: Press the key to display CHANGE menu.
  - Use the keys to select the positioning of the characters (44 characters spaced over 2 lines).
  - Use the keys to select each character.
  - When the message has been entered:
  - Press the blue key to return to previous menu.
  - RUN: Press the key to switch to ON.
  - Exit from the menu by pressing the blue key.
  - ▶ The message will remain on the screen.
  - To erase the message: Press the blue key.
- N.B.:* The message will reappear every time the TV is switched on.
- To cancel: Switch RUN back to OFF.
  - CLEAR: Press key to erase message.
  - To exit: Press the blue key repeatedly.

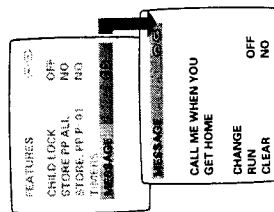

12



**Teletext (special features)**

- ① **Temporary interruption of the display**  
To stop or return to the selected display. The symbol is displayed and the television programme reappears on the screen. This function allows you to wait when the search for pages takes a long time.
- ② **Enlarging a page**  
To display the upper part, the lower part and then to return to the normal page size.
- ③ **Overlaying teletext on the TV picture**  
To activate/deactivate the screen overlay.
- ④ **Reveal**  
To reveal/conceal hidden information (solutions to games or questions/answers).
- ⑤ **Stop the sequence of sub-pages (hold)**  
Appears on the top left-hand corner of the screen. You stop or start the sequence. The message disappears automatically. If this is the case, this key will allow you to access a sub-page directly, press ⑥. The page number followed by four dashes will appear in the bottom left-hand corner of the screen. Type the number of the sub-page required using 4 numbers. E.g. type 0002 to consult sub-page 2. The page counter searches and then the sub-page is displayed. Press ⑦ to return to current page.
- ⑥ **Direct selection**  
To access a sub-page directly, press ⑥. The page number followed by four dashes will appear in the bottom left-hand corner of the screen. Type the number of the sub-page required using 4 numbers. E.g. type 0002 to consult sub-page 2. The page counter searches and then the sub-page is displayed. Press ⑦ to return to current page.
- ⑦ **Consult the main index to find out the page number for subtitles**  
Enter the subtitles page number (e.g. 888). The page counter searches and then the subtitles appear on screen. If no subtitles are available the page counter will continue to search. To exit from subtitles, press ⑧. When subtitles is switched on, you have to switch off teletext (key) to be able to change programmes.



**Teletext**

Teletext is an information system, broadcast by certain TV channels, which can be consulted in the same way as a newspaper. It also provides subtitles for the hard of hearing or people who are unfamiliar with the broadcast language (cable TV network, satellite channel, etc.).

**Press:** **Result:** Display or exit from teletext. The main index page presents a list of subjects to which you have access. Each subject has a corresponding page number (always 3 digits). If the selected TV channel does not broadcast teletext, P100 is displayed and the screen remains black (if this is the case, switch off teletext and choose another TV channel).

**①/② Selecting a page**  
To type in the page number required. E.g. page 120, type ① ②. The number is displayed in the top left-hand corner of the screen, the page counter starts searching and then the page selected is displayed. Repeat to consult another page. If > xxx < flashes briefly or the counter continues searching, this means the page selected is not broadcast or is not available. If this is the case, choose another number.

**③ Switch teletext on/off**  
The main index page presents a list of subjects to which you have access. Each subject has a corresponding page number (always 3 digits). If the selected TV channel does not broadcast teletext, P100 is displayed and the screen remains black (if this is the case, switch off teletext and choose another TV channel).

- ④ **Previous page/Next page**  
To consult the previous page (-) or the next page (+).
- ⑤ **Direct access to a subject**  
Coloured zones are displayed at the bottom of the screen. The coloured keys allow access to the subjects or their corresponding pages.
- ⑥ **Main index**  
To return to the main index (generally on page 100), press the white key.
- ⑦ **Previous page**  
To return to the page displayed previously.

**Connecting peripheral equipment**

The EXT2 socket has audio and video inputs/outputs and RGB inputs. The EXT2 socket has audio and video inputs/outputs and S-VHS inputs. For further information see battery (p. 18).

**Video recorder ...with Decoder**



- If your video recorder has a euroconnector socket, carry out the above connections. Euroconnector sockets ensure better picture quality.
- If your video recorder does not have a euroconnector socket (or if this is already being used by another device), then the only connection possible is via the serial cable. Your video recorder is then considered as a TV programme by your TV set. You will therefore need to tune in your video recorder's test signal and assign it programme number 0 (see manual store chapter, p. 5).
- To reproduce the video recorder picture, press the key. Refer to your video recorder's operating instructions concerning the test signal (the video recorder must be equipped with an Hi-Fi module).

**Connecting other equipment**

(satellite receiver, decoder, CDV/CDI, games...) Connect to EXT1 socket. If the external product produces S-VHS signals, it should be connected to the EXT2 socket.

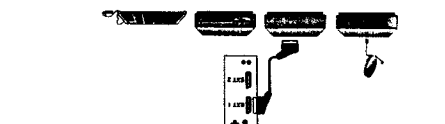

- Use key to select E1 (EXT1), E2 (EXT2) or for S-VHS or Hi-8 equipment, E2 V/C. Most equipment (decoder, video recorder) carries out the switchover itself.

- On the video recorder, select the euroconnector socket as the recording source.
- Press to select E1.
- Carry out one of the following connections, then:
  - ① To make a copy of recordings:

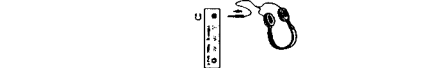

To adjust the headphones volume, use the HEADPHONES adjustment in the SOUND menu (p. 10). To adjust the volume on the TV set, use the or keys. You can also access the HEADPHONES adjustment directly using programmable keys and on the remote control (see p. 8).

**Headphones**

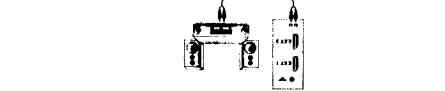

Use an audio connection cable and connect the sockets "L" and "R" on the set to the "AUDIO IN" "L" and "R" input on your Hi-Fi amplifier.

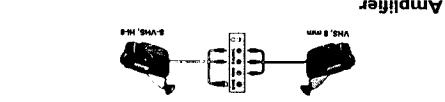

- Carry out one of the following connections and then:
  - Use the key to select E2 (for VHS or Hi8 cameras) or E2 V/C (S-VHS or Hi-8 cameras).
  - NB: if a peripheral is connected to EXT2, it is advisable to switch it off while using S-VHS connectors.

**Front connections**



## 11. List of abbreviations

AC	Alternating Current
AF_AMP	Audio frequency amplifier
AGC	Automatic gain control
AM	Amplitude modulation
ATS	Automatic Tuning System
AQUADAG	Earth from the CRT
AUD_TERR_AM	Audio (AM) from the antenna
AUDI_TERR_AM	Audio (AM) from the antenna
AUDIO L	Audio left
AUDIO R	Audio right
AUDIO_L	Left to DBE module
AUDIO_R	Right to DBE module
<b>B</b>	Blue signal to CRT panel
B_IN	Blue signal input
BC_INFO	Beam current information
B_SC_INPUT	Blue input from Euro connector
B_TXT	Blue Teletext signal
(B-Y) IN	B-Y input signal
(B-Y) OUT	Colour difference signal out
BC_INFO	Black current info from CRT panel
BG DK STEREO	System PAL BG DK; stereo sound
BG LI NICAM	System PAL BGI; NICAM sound
BG LI STEREO	The stereo signal from PAL BGI or SECAM L
BG_ST/NIC	System BG stereo with NICAM sound
Bk	Burst key pulse
BLANK	Blanking signal
BLK	Black stretch
BLKSTR	Black stretch
BLK	Black line S
BLS	Blank screen, signal from the microcomputer
BLKSCREEN	Blank matrix
BM	Blue on screen display signal
B_OSD	Blue on screen display signal
C_AFU	Centre signal to module
C_FILTER	Chrominance filter
C_FRONT	Chrominance signal from separate controls panel
C_INPUT	Chrominance from Euro connector 2
CRT	Cathode ray tube
CRT...	Indicator for different CRT types
CTI	Colour transient improvement
CURRSENZE	Current sense to detect current
CUT_OFF	Signal to align the black level of the RGB signals
CVBS	Composite Video Blanking Synchronisation
CVBSY_FRONT	CVBS or luminance from separate controls
CVBSY_SC2/Front_INPUT	CVBS/luminance signal from Euro connector/front input
CVBS_COMB/TXT	CVBS signal to teletext
CVBS_SC1_INPUT	CVBS signal from Euro connector 1
CVBS_SC2	CVBS signal from Euro connector 2
CVBS_SC2_OUT	CVBS outgoing signal from Euro connector 2
CVBS_SECAM	CVBS signal to SECAM IC
CVBS_TERR	CVBS from the antenna
CVBS_TERR/SAT	CVBS Signal from antenna or from satellite
CVBS_TXT	CVBS to Teletext
CVBS_SAT	CVBS signal from satellite tuner
D/A	Digital to analogue converter
DACA_L	Left output signal from DFP to headphone (independent volume controlled)
DACA_R	Right output signal from DFP to headphone (independent volume controlled)
DACAM_L	Left output signal from DFP to loudspeaker
DACAM_R	Right output signal from DFP to loudspeaker
DC	Direct Current
DEGAUSS	Degaussing
DELAY	Luminance delay
DET	Detector
DFP	Digital Sound Processor
DEM0D	Demodulator
EAR1	Earth 1 (ground)
EARTH	Earth (ground)
EAST EU	East Europe
EHT	Extra high tension
EHTINFO	Voltage related to beam current
EHTINFO1	Voltage related to beam current to CRT panel
EW	East-west
EW_COMP	East-west compensation
EW_D	East-west drive
FBI_IN	Fast blanking in
FBI_OFF	Fast blanking off
FBL_PRESENT	From Euro connector, detects if there is a full page RGB at the Euro connector or OSD or a MENU from an external source
FILA_CRT	Filament for the CRT
FM	Frequency modulation
FOLDB	Foldback
FRAMEDEFL_R	Frame deflection right signal
FRONT_DETECT	Signal to detect if on separate controls panel video signals are present
FRONT_INPUT	Input from separate controls panel at front side of the TV set
G_IN	Green signal in
G_OSD	Green (on screen display) signal
G_SC_INPUT	Green input from Euro connector
G_TXT	Green Teletext signal
G-Y	Colour difference signal
G_Y MATRIX	RGB luminance matrix
GND..	Ground ..
GND_AUDIO	Ground
GND_KEYBOARD	Ground of keyboard
GND_LIGHTNING	Ground on mains module
GND_LINE_SS	Ground from SS-panel for line drive
GND_SOUND_SUPPLY	Ground to the audio amplifier
GND_VO	Ground to the deflection
GND_B	Ground B
GND_D	Ground D
GNDV	Green signal to CRT panel
H	Horizontal pulse
HDRIVE	Horizontal drive signal
HEATER	Output voltage to the tube heater
HFBL	Feedback from line deflection
HPUULSE	From deflection module, horizontal pulse for OSD synchronisation
HIST	Histogram
I/BG	To Sound module, selects the audio system
IDENT	Identification
I NICAM	System NICAM/PAL I
IF	Intermediate-frequency
INT/EXT	Internal or external switching
IRQ	From the Satellite or Teletext module, interrupt signal from these modules
ITT	Type indication Sound module
I/C	Inter IC bus
I/O	Input/Output
LED	Light emitting diode
LF	Low frequency
L/L	To BIMOS module and Sound module, switches between the L and L' system
LINEDEFL_CS	Connection for geometry correction panels
LINEDEFL_LIN	Connection for geometry correction panels
LOT	Line output transformer
NC	Not connected
NICAM	Near Instantaneous Compensating Audio Multiplex (digital sound system)
NICAM L	System L-NICAM
NO_NORDIC	Not used in set for Nordic countries
NTSCM/BG	Switching signal
OK	Correct
OSC	Oscillator

For Service Manuals Contact  
**MAURITRON TECHNICAL SERVICES**  
 8 Cherry Tree Rd, Chinnor  
 Oxon OX9 4QY  
 Tel:- 01844-351694 Fax:- 01844-352554  
 Email:- enquiries@mauritron.co.uk

PAL	Phase Alternating Line (colour system)
P_GND	Audio power ground
PHASE COMP	Phase compensation
PLL	Phase lock loop
POR	Power-on reset
PROT	Protection
R	Red signal to CRT panel
RC5	Remote Control signal
R-IN	Red input signal
(R-Y)IN	Colour difference (R-Y) input signal
R_OS	Red (on screen display) signal
R_SC INPUT	Red input from Euro connector
R_TXT	Red Teletext
R_Y OUT	Colour difference signal out
RGB	Red Green Blue
SAND	Sand castle
SAND1	Sand castle signal to Scan module
SBUS	Sound bus
SCART_L	Sound signal L from Euro connector
SCART_R	Sound signal R from Euro connector
SAT	Satellite
SCL	I <sup>2</sup> C Clock signal
SDA	I <sup>2</sup> C data
SDAa	To every other module, serial data
SDAI	Serial data pulse
SECAM	SEquentiel Couleur A Memoire (colour system)
SECAM L	System L-SECAM
SELECT	Selection signal for Euroconnectors or separate controls
SEP CTRL	Separate controls
SF	Super flat
SIF	Sound IF
SIF SAT	Sound IF from satellite tuner
SNDL	Sound left
SNDL_CL_OUTPUT	Left sound to CL output from sound module
SNDL_FRONT	Left sound signal from separate controls panel
SND_HEADP_OUTPUT	Output sound left to the headphone connector
SNDL_SC1_INPUT	Left sound output signal from the audio module
SNDL_SC1_OUTPUT	Output signal, sound left to Euro connector 1
SNDL_SC2_FRONT_INPUT	Input signal sound L from Euro connector 2 or front input
SNDL_SC2_OUTPUT	Output signal sound L to Euro connector 2
SNDL_SPEAKER	Sound L signal to loudspeaker
SNDR	Sound right
SNDR_C1/L_OUTPUT	Right CL/VL audio signal from Dolby
SNDR_CL_OUTPUT	Sound right, constant level output to rear citches
SNDR_FRONT	Sound right from separate controls panel
SNDR_HEADP_OUTPUT	Output sound right to the headphone connector
SNDR_SC1_INPUT	Input signal, sound right to Euro connector 1
SNDR_SC1_OUTPUT	Output signal sound R to Euro connector 1
SNDR_SC2_OUTPUT	Right sound to Euro connector 2 output from sound module
SNDR_SPEAKER	Sound R signal to loudspeaker
SNDR_SUBW	Sound R signal to subwoofer
SOUND_ENABLE	To the Audio Amplifier module, switches on and off the amplifier
SOUND_SUP	Supply voltage of amplifier
STANDBY	To supply module, switches the set in and out of standby
STATUS1	Status signal from Euro connector input to control module
STATUS2	Status signal from Euro connector 2 input to control module
STD.	Indicator for different standards
SVHS	Super VHS
SYNC	Synchronisation signal
SYNC_TXT	Synchronisation signal from Teletext
SYS	System switching signal
SYS.	Indicator for different systems
1SC	One carrier sound
2SC	Two carrier sound

TCLK	Teletext clock signal
TDATA	Teletext data signal
TUNING	Tuning voltage
TUN	Indicator for different tuners
VDRIVE	Vertical drive
VDRIVE+VD	Vertical drive positive side
V0S	140 Volt (95 Volt for 21")
VFRAME (+ or -)	Positive or negative supply voltage for frame amplifier
VG1_CRT	VG1 input to the picture tube
VG2	G2 input to the picture tube
VIF	Video intermediate frequency
VDD	Supply voltage
V0D	Voltage used in horizontal output stage
V0D1	Voltage used in horizontal output stage
V0LOT	Voltage to line output transformer
V0CONN	Voltage to Scan module
VP	Video processor
VPROT	Protection voltage
VPULSE	From deflection module, vertical pulse for OSD synchronisation
VSS	Ground
VSCAVEM	Supply voltage for SCAVEM
VT	Tuning voltage
Y_COMB	Y (or CVBS) signal to TDA8366
Y_FRONT	Luminance signal from separate controls panel
Y_OUT	Luminance signal out
YUV_ON/OFF	To Histogram/black stretch module, switch on & off
UPR	Indicator for different control systems
WEST-EU	West Europe
21" EUR	21" Europe
+	Present, in diversity tables
.	Not present in diversity tables



Part No.	Description	Part No.	Description	Part No.	Description	Part No.	Description	Part No.	Description	Part No.	Description	Part No.	Description	Part No.	Description				
3969	4822 051 20234 200F 5% 0.1W	3970	4822 051 20234 200F 5% 0.1W	3971	4822 051 20234 200F 5% 0.1W	3972	4822 051 20234 200F 5% 0.1W	3973	4822 051 20234 200F 5% 0.1W	3974	4822 051 20234 200F 5% 0.1W	3975	4822 051 20234 200F 5% 0.1W	3976	4822 051 20234 200F 5% 0.1W	3977	4822 051 20234 200F 5% 0.1W	3978	4822 051 20234 200F 5% 0.1W

For Service Manuals Contact MAURITRON TECHNICAL SERVICES 8 Cherry Tree Rd, Chinnor Oxon OX9 4QY Tel: 01844-351634 Fax: 01844-352554 Email: enquiries@mauritron.co.uk

Service  
Service  
**Service**

**MD1.2E**  
AA  
SUPPLEMENT

For Service Manuals Contact  
**MAURITRON TECHNICAL SERVICES**  
8 Cherry Tree Rd, Chinnor  
Oxon OX9 4QY  
Tel:- 01844-351694 Fax:- 01844-352554  
Email:- enquiries@mauritron.co.uk

# Service Manual

Supplement for Chassis Manual MD1.2E AA 4822 727 20979

## Contents

## Page

2.	Connection facilities		2	
	PWB location drawing		2	
4.	Mechanical instructions		3	
5.	Wiring diagram		3	
7.	<i>Electrical diagrams and PWB-layouts</i>		<i>Diagram</i>	<i>PWB</i>
	CRT/Scavem panel	(Diagram C)	4	5
	Surround Sound Amplifier panel	(Diagram H1)	6	6
	Click-fit panel	(Diagram H2)	7	7
	DBE panel	(Diagram H3)	8	8
	Mains + Front control panel	(Diagram J)	9	9
	16:9 panel	(Diagram L)	10	11
	Audio module (Dolby)	(Diagram P)	12	11
	Mains/RC5/LED panel (Classic line)	(Diagram T)	13	13
8.	Electrical adjustments		14	
9.	Circuit description		14	
10.	Directions for use		16	
11.	List of abbreviations		18	
12.	Spare parts list		18	



## 2. Connection facilities

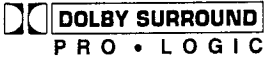

Manufactured under license from Dolby Laboratories Licensing Corporation.

DOLBY, the double-D symbol and PRO LOGIC are trademarks of Dolby Laboratories Licensing Corporation.

### Rear connections (Dolby Pro Logic)

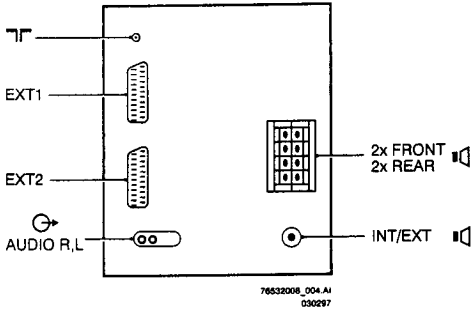

### PWB location drawing

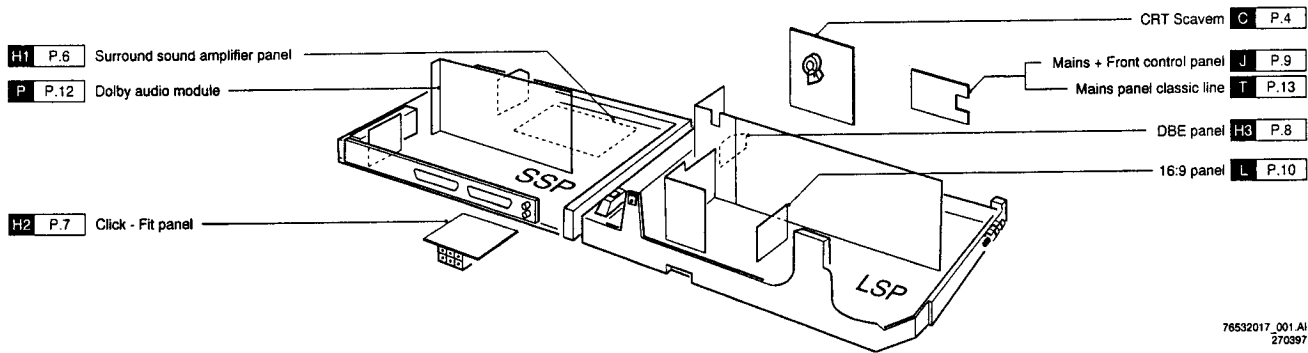

## 4. Mechanical instructions

The service positions for the MD1.2E are described in Service Manual MD1.2E AA. Here are several supplements for 16:9 and Dolby sets.

### 4.1 16:9 sets with rotation coil

To put sets with a rotation coil into the various service positions the connection between the rotation coil and connector F93 on the 16:9 panel has to be disconnected. The set will continue to function normally, but the picture can no longer be tilted.

### 4.2 Dolby Pro Logic sets

#### 4.2.1 Click-fit panel

The click-fit panel is fitted to the cover plate by screws located above and below the loudspeaker connections.

#### 4.2.2 DBE module

The DBE module can be removed for repair, module replacement, or for making repairs to the LSP in the vicinity of the DBE module. If the DBE is removed the set will continue to function normally but without sound.

#### 4.2.3 Surround Sound Amplifier (Fig. 4.1)

The Surround Sound Amplifier panel can be removed from the bracket in the following manner:

1. Press click (1) inwards;
2. Pull bracket (2) outwards;
3. The Surround Sound Amplifier panel can now be pulled forward (3).

#### 4.2.4 Component side Small Signal Panel (SSP)

To access the component side of the SSP it is necessary to remove the Surround Sound Amplifier, including the bracket:

1. Press the click (4) inwards;
  2. Lift the bracket and pull it forward (5).
- The component side of the SSP is now accessible.

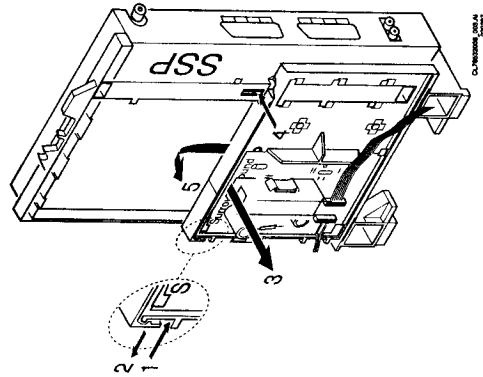
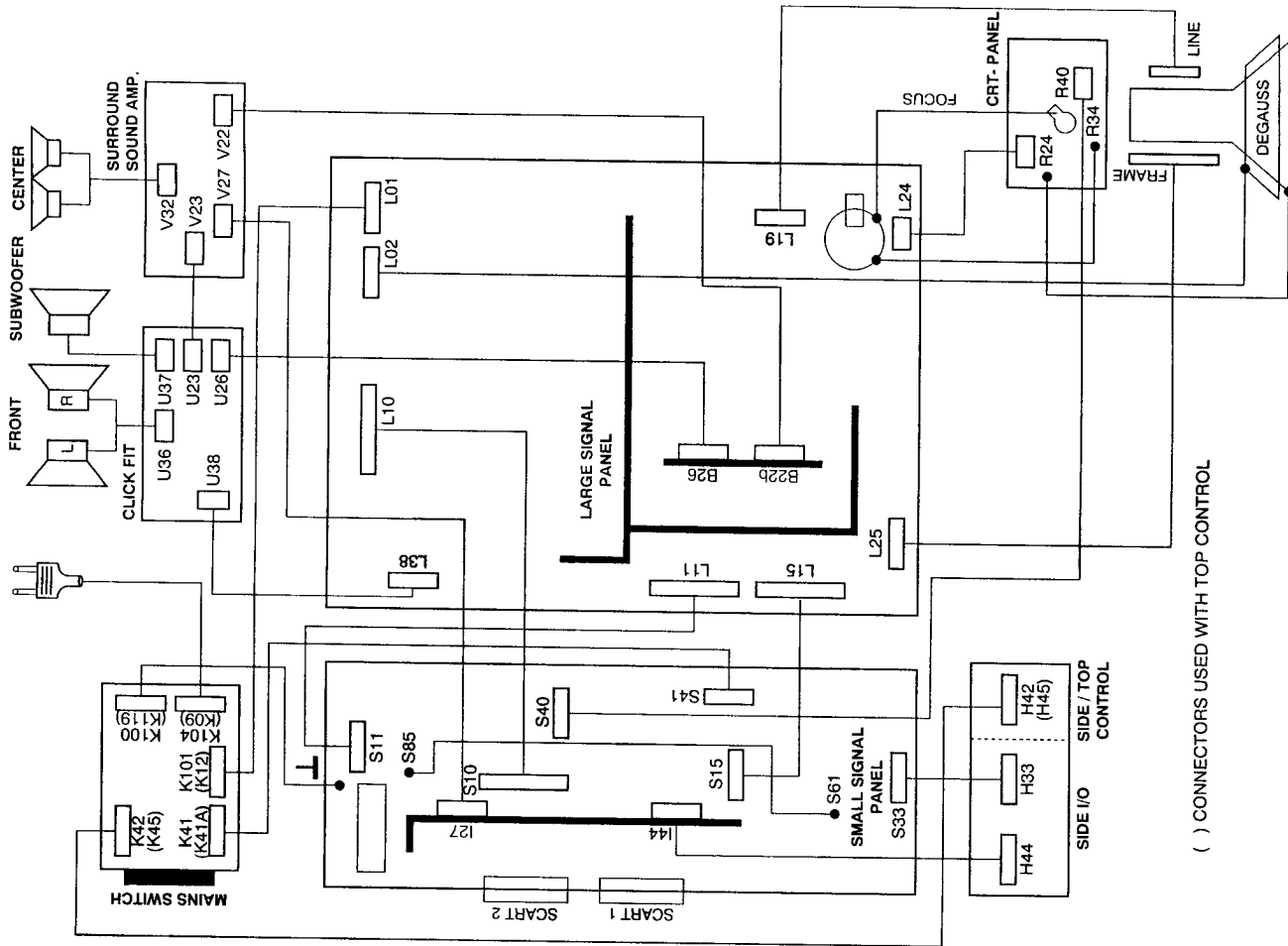

Fig. 4.1

## 5. Wiring diagram / Verdrahtungsschema / Schéma de câblage



CL: 76532008\_001.AI  
250397

For Service Manuals Contact  
**MAURITRON TECHNICAL SERVICES**  
 8 Cherry Tree Rd, Chinnor  
 Oxon OX9 4QY  
 Tel: 01844-351694 Fax: 01844-352554  
 Email: enquiries@mauritron.co.uk





2300 A 1	2501 A 1	3100 A 1	3300 A 1	3310 A 1	3310 A 2	3310 A 3	3310 A 4	3310 A 5	3310 A 6	3310 A 7	3310 A 8	3310 A 9	3310 A 10	3310 A 11	3310 A 12	3310 A 13	3310 A 14	3310 A 15	3310 A 16	3310 A 17	3310 A 18	3310 A 19	3310 A 20	3310 A 21	3310 A 22	3310 A 23	3310 A 24	3310 A 25	3310 A 26	3310 A 27	3310 A 28	3310 A 29	3310 A 30	3310 A 31	3310 A 32	3310 A 33	3310 A 34	3310 A 35	3310 A 36	3310 A 37	3310 A 38	3310 A 39	3310 A 40	3310 A 41	3310 A 42	3310 A 43	3310 A 44	3310 A 45	3310 A 46	3310 A 47	3310 A 48	3310 A 49	3310 A 50	3310 A 51	3310 A 52	3310 A 53	3310 A 54	3310 A 55	3310 A 56	3310 A 57	3310 A 58	3310 A 59	3310 A 60	3310 A 61	3310 A 62	3310 A 63	3310 A 64	3310 A 65	3310 A 66	3310 A 67	3310 A 68	3310 A 69	3310 A 70	3310 A 71	3310 A 72	3310 A 73	3310 A 74	3310 A 75	3310 A 76	3310 A 77	3310 A 78	3310 A 79	3310 A 80	3310 A 81	3310 A 82	3310 A 83	3310 A 84	3310 A 85	3310 A 86	3310 A 87	3310 A 88	3310 A 89	3310 A 90	3310 A 91	3310 A 92	3310 A 93	3310 A 94	3310 A 95	3310 A 96	3310 A 97	3310 A 98	3310 A 99	3310 A 100
----------	----------	----------	----------	----------	----------	----------	----------	----------	----------	----------	----------	----------	-----------	-----------	-----------	-----------	-----------	-----------	-----------	-----------	-----------	-----------	-----------	-----------	-----------	-----------	-----------	-----------	-----------	-----------	-----------	-----------	-----------	-----------	-----------	-----------	-----------	-----------	-----------	-----------	-----------	-----------	-----------	-----------	-----------	-----------	-----------	-----------	-----------	-----------	-----------	-----------	-----------	-----------	-----------	-----------	-----------	-----------	-----------	-----------	-----------	-----------	-----------	-----------	-----------	-----------	-----------	-----------	-----------	-----------	-----------	-----------	-----------	-----------	-----------	-----------	-----------	-----------	-----------	-----------	-----------	-----------	-----------	-----------	-----------	-----------	-----------	-----------	-----------	-----------	-----------	-----------	-----------	-----------	-----------	-----------	-----------	-----------	-----------	-----------	-----------	-----------	------------

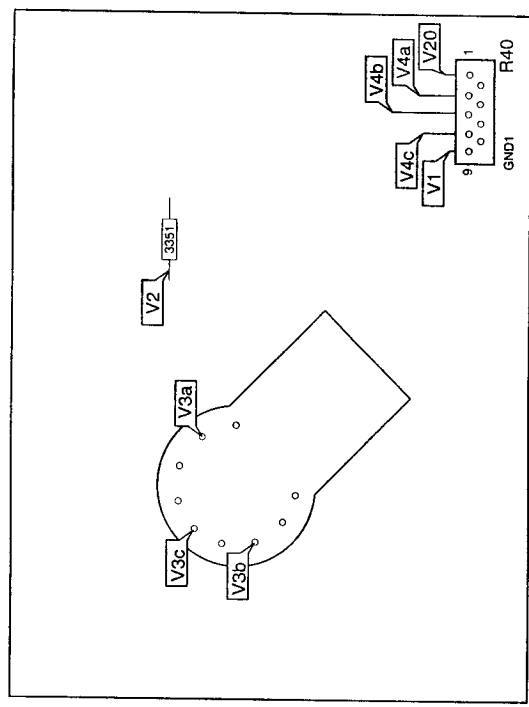
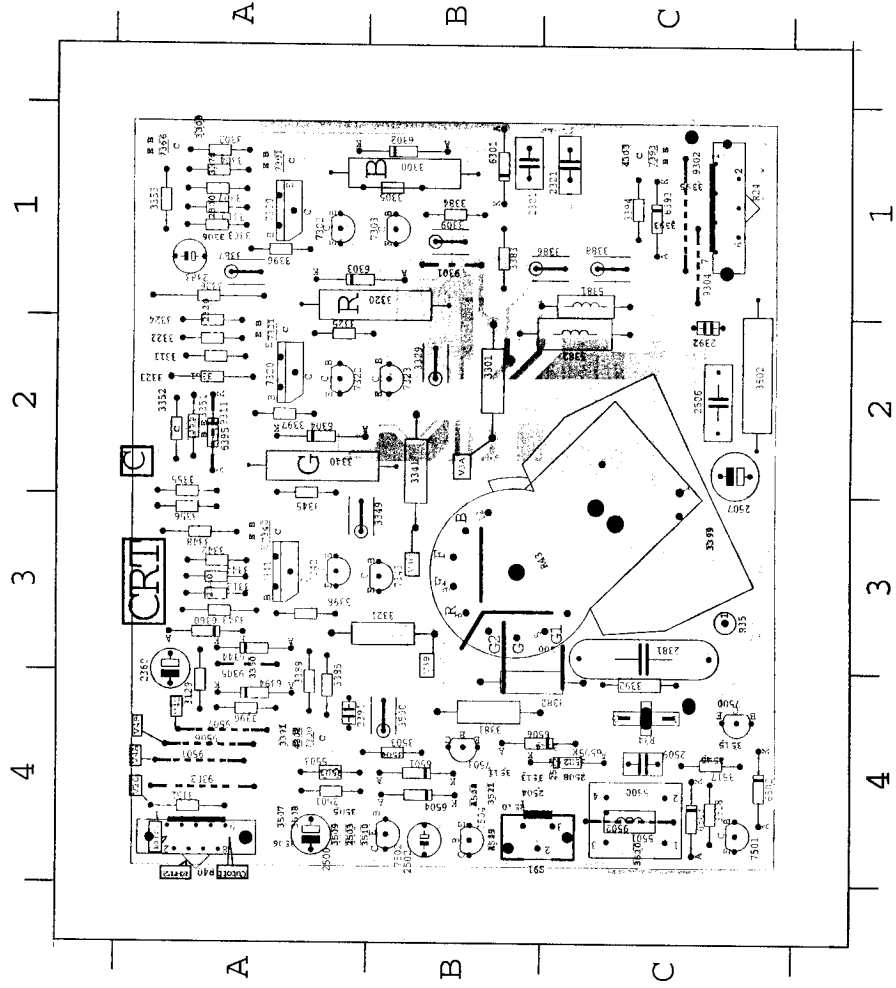

CL 7632003\_000.ap  
250397

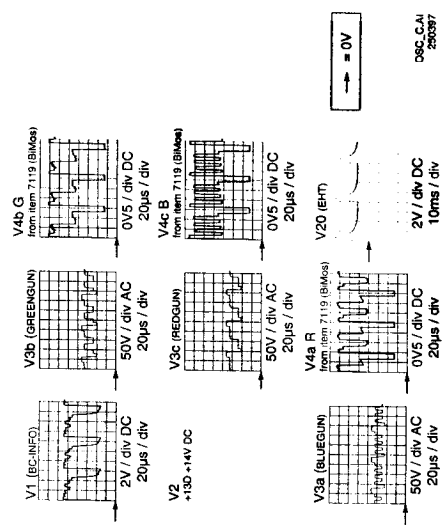

For Service Manuals Contact  
**MAURITRON TECHNICAL SERVICES**  
 8 Cherry Tree Rd, Chinnor  
 Oxon OX9 4QY  
 Tel: 01844-351694 Fax: 01844-352554  
 Email: enquiries@mauritron.co.uk

0001 A.2	2151 A.2	2154 A.2	2157 A.2	2160 A.2	2163 A.2	2166 A.2	2169 A.2	2172 A.2	2175 A.2	2178 A.2	2181 A.2	2184 A.2	2187 A.2	2190 A.2	2193 A.2	2196 A.2	2199 A.2	2202 A.2	2205 A.2	2208 A.2	2211 A.2	2214 A.2	2217 A.2	2220 A.2	2223 A.2	2226 A.2	2229 A.2	2232 A.2	2235 A.2	2238 A.2	2241 A.2	2244 A.2	2247 A.2	2250 A.2	2253 A.2	2256 A.2	2259 A.2	2262 A.2	2265 A.2	2268 A.2	2271 A.2	2274 A.2	2277 A.2	2280 A.2	2283 A.2	2286 A.2	2289 A.2	2292 A.2	2295 A.2	2298 A.2	2301 A.2	2304 A.2	2307 A.2	2310 A.2	2313 A.2	2316 A.2	2319 A.2	2322 A.2	2325 A.2	2328 A.2	2331 A.2	2334 A.2	2337 A.2	2340 A.2	2343 A.2	2346 A.2	2349 A.2	2352 A.2	2355 A.2	2358 A.2	2361 A.2	2364 A.2	2367 A.2	2370 A.2	2373 A.2	2376 A.2	2379 A.2	2382 A.2	2385 A.2	2388 A.2	2391 A.2	2394 A.2	2397 A.2	2400 A.2	2403 A.2	2406 A.2	2409 A.2	2412 A.2	2415 A.2	2418 A.2	2421 A.2	2424 A.2	2427 A.2	2430 A.2	2433 A.2	2436 A.2	2439 A.2	2442 A.2	2445 A.2	2448 A.2	2451 A.2	2454 A.2	2457 A.2	2460 A.2	2463 A.2	2466 A.2	2469 A.2	2472 A.2	2475 A.2	2478 A.2	2481 A.2	2484 A.2	2487 A.2	2490 A.2	2493 A.2	2496 A.2	2499 A.2	2502 A.2	2505 A.2	2508 A.2	2511 A.2	2514 A.2	2517 A.2	2520 A.2	2523 A.2	2526 A.2	2529 A.2	2532 A.2	2535 A.2	2538 A.2	2541 A.2	2544 A.2	2547 A.2	2550 A.2	2553 A.2	2556 A.2	2559 A.2	2562 A.2	2565 A.2	2568 A.2	2571 A.2	2574 A.2	2577 A.2	2580 A.2	2583 A.2	2586 A.2	2589 A.2	2592 A.2	2595 A.2	2598 A.2	2601 A.2	2604 A.2	2607 A.2	2610 A.2	2613 A.2	2616 A.2	2619 A.2	2622 A.2	2625 A.2	2628 A.2	2631 A.2	2634 A.2	2637 A.2	2640 A.2	2643 A.2	2646 A.2	2649 A.2	2652 A.2	2655 A.2	2658 A.2	2661 A.2	2664 A.2	2667 A.2	2670 A.2	2673 A.2	2676 A.2	2679 A.2	2682 A.2	2685 A.2	2688 A.2	2691 A.2	2694 A.2	2697 A.2	2700 A.2	2703 A.2	2706 A.2	2709 A.2	2712 A.2	2715 A.2	2718 A.2	2721 A.2	2724 A.2	2727 A.2	2730 A.2	2733 A.2	2736 A.2	2739 A.2	2742 A.2	2745 A.2	2748 A.2	2751 A.2	2754 A.2	2757 A.2	2760 A.2	2763 A.2	2766 A.2	2769 A.2	2772 A.2	2775 A.2	2778 A.2	2781 A.2	2784 A.2	2787 A.2	2790 A.2	2793 A.2	2796 A.2	2799 A.2	2802 A.2	2805 A.2	2808 A.2	2811 A.2	2814 A.2	2817 A.2	2820 A.2	2823 A.2	2826 A.2	2829 A.2	2832 A.2	2835 A.2	2838 A.2	2841 A.2	2844 A.2	2847 A.2	2850 A.2	2853 A.2	2856 A.2	2859 A.2	2862 A.2	2865 A.2	2868 A.2	2871 A.2	2874 A.2	2877 A.2	2880 A.2	2883 A.2	2886 A.2	2889 A.2	2892 A.2	2895 A.2	2898 A.2	2901 A.2	2904 A.2	2907 A.2	2910 A.2	2913 A.2	2916 A.2	2919 A.2	2922 A.2	2925 A.2	2928 A.2	2931 A.2	2934 A.2	2937 A.2	2940 A.2	2943 A.2	2946 A.2	2949 A.2	2952 A.2	2955 A.2	2958 A.2	2961 A.2	2964 A.2	2967 A.2	2970 A.2	2973 A.2	2976 A.2	2979 A.2	2982 A.2	2985 A.2	2988 A.2	2991 A.2	2994 A.2	2997 A.2	3000 A.2
----------	----------	----------	----------	----------	----------	----------	----------	----------	----------	----------	----------	----------	----------	----------	----------	----------	----------	----------	----------	----------	----------	----------	----------	----------	----------	----------	----------	----------	----------	----------	----------	----------	----------	----------	----------	----------	----------	----------	----------	----------	----------	----------	----------	----------	----------	----------	----------	----------	----------	----------	----------	----------	----------	----------	----------	----------	----------	----------	----------	----------	----------	----------	----------	----------	----------	----------	----------	----------	----------	----------	----------	----------	----------	----------	----------	----------	----------	----------	----------	----------	----------	----------	----------	----------	----------	----------	----------	----------	----------	----------	----------	----------	----------	----------	----------	----------	----------	----------	----------	----------	----------	----------	----------	----------	----------	----------	----------	----------	----------	----------	----------	----------	----------	----------	----------	----------	----------	----------	----------	----------	----------	----------	----------	----------	----------	----------	----------	----------	----------	----------	----------	----------	----------	----------	----------	----------	----------	----------	----------	----------	----------	----------	----------	----------	----------	----------	----------	----------	----------	----------	----------	----------	----------	----------	----------	----------	----------	----------	----------	----------	----------	----------	----------	----------	----------	----------	----------	----------	----------	----------	----------	----------	----------	----------	----------	----------	----------	----------	----------	----------	----------	----------	----------	----------	----------	----------	----------	----------	----------	----------	----------	----------	----------	----------	----------	----------	----------	----------	----------	----------	----------	----------	----------	----------	----------	----------	----------	----------	----------	----------	----------	----------	----------	----------	----------	----------	----------	----------	----------	----------	----------	----------	----------	----------	----------	----------	----------	----------	----------	----------	----------	----------	----------	----------	----------	----------	----------	----------	----------	----------	----------	----------	----------	----------	----------	----------	----------	----------	----------	----------	----------	----------	----------	----------	----------	----------	----------	----------	----------	----------	----------	----------	----------	----------	----------	----------	----------	----------	----------	----------	----------	----------	----------	----------	----------	----------	----------	----------	----------	----------	----------	----------	----------	----------

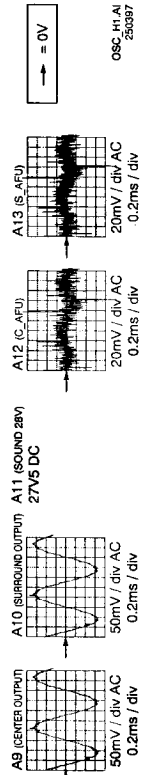
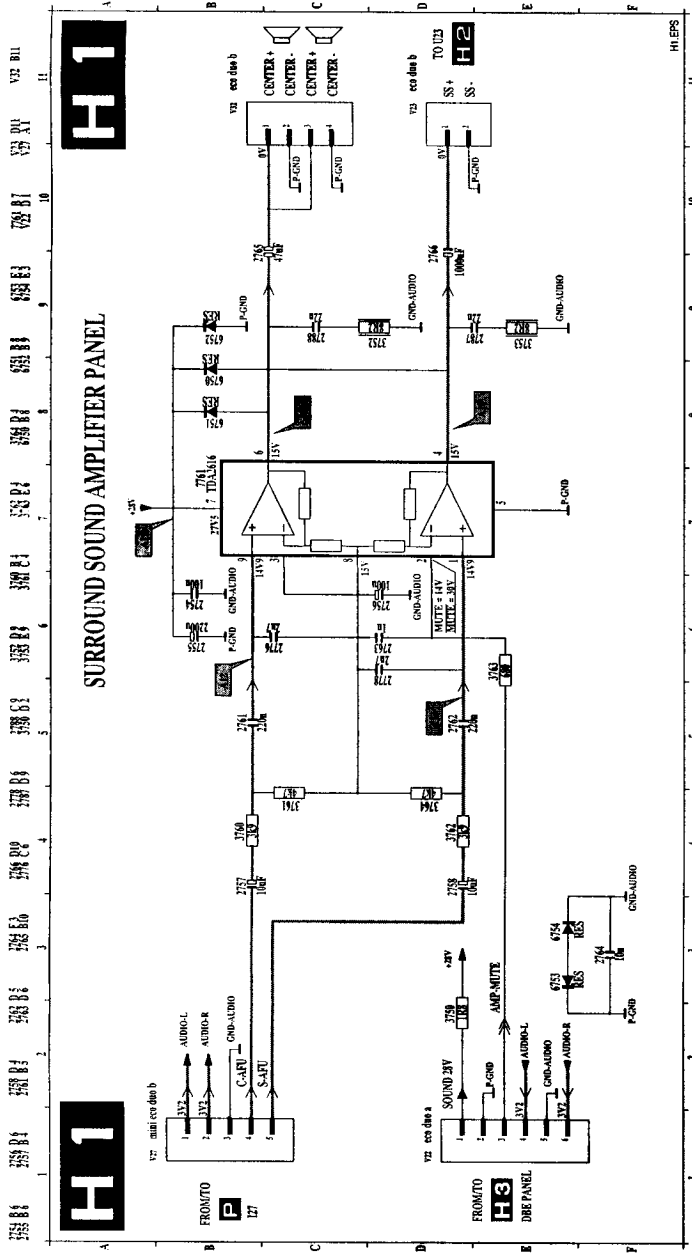
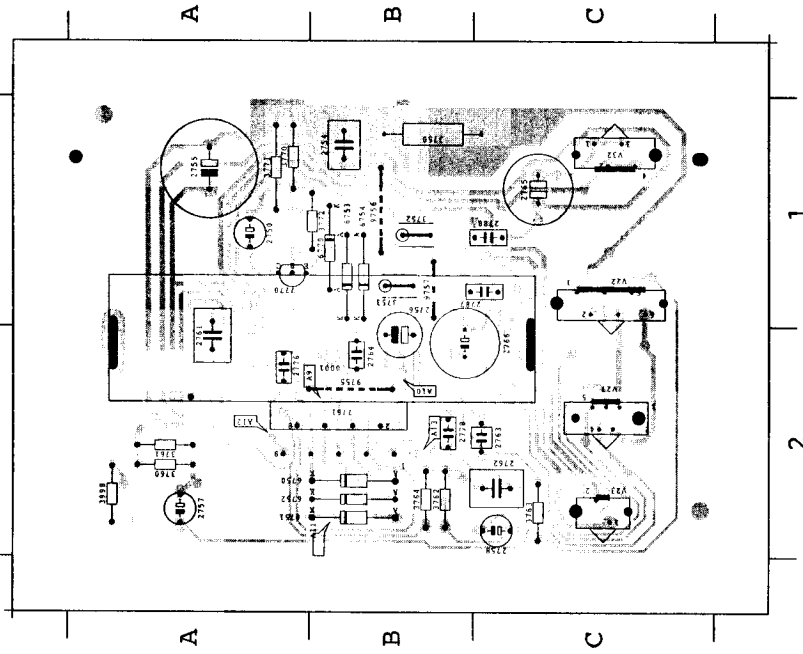

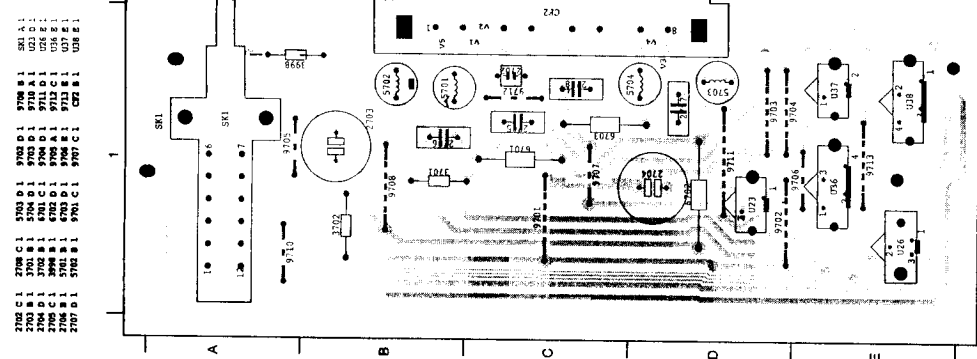
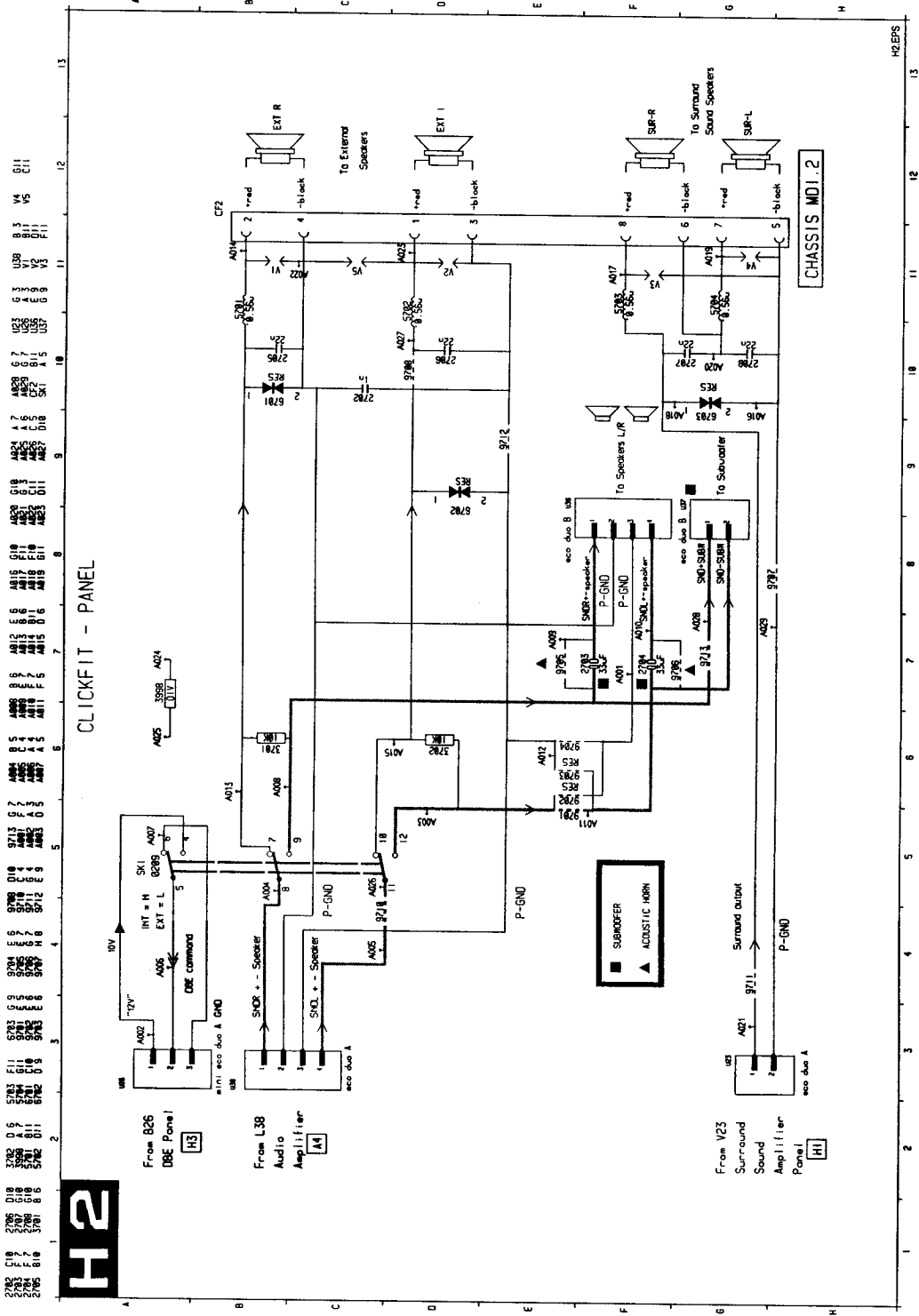

For Service Manuals Contact  
**MAURITRON TECHNICAL SERVICES**  
 8 Cherry Tree Rd, Chinnor  
 Oxon OX9 4QY  
 Tel:- 01844-351694 Fax:- 01844-352554  
 Email:- enquiries@mauritron.co.uk







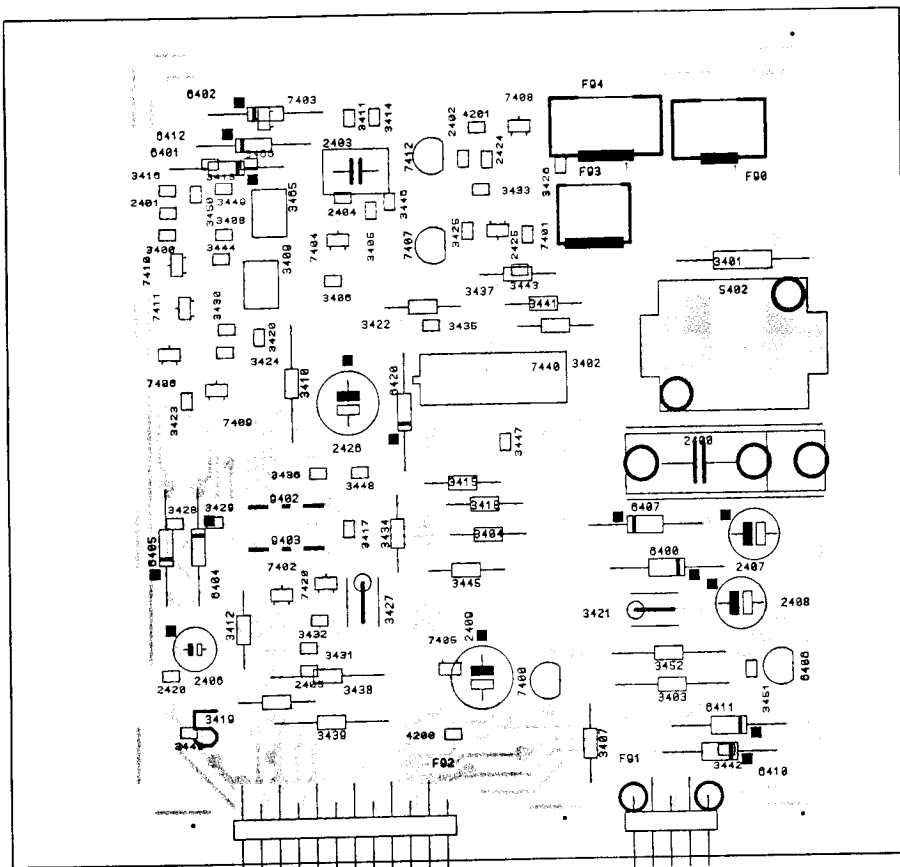

For Service Manuals Contact  
**MAURITRON TECHNICAL SERVICES**  
 8 Cherry Tree Rd, Chinnor  
 Oxon OX9 4QY  
 Tel:- 01844-351694 Fax:- 01844-352554  
 Email:- enquiries@mauritron.co.uk

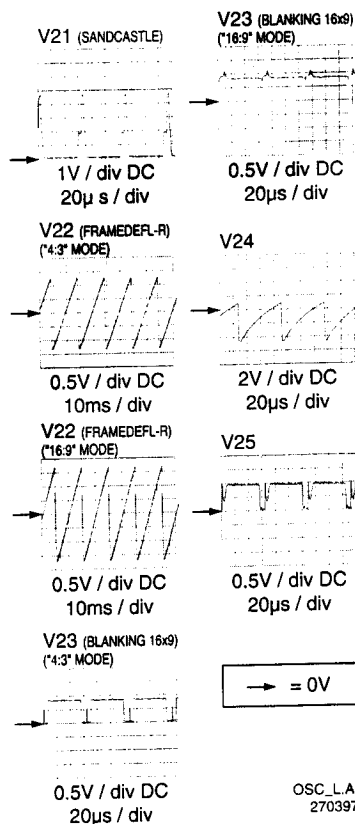
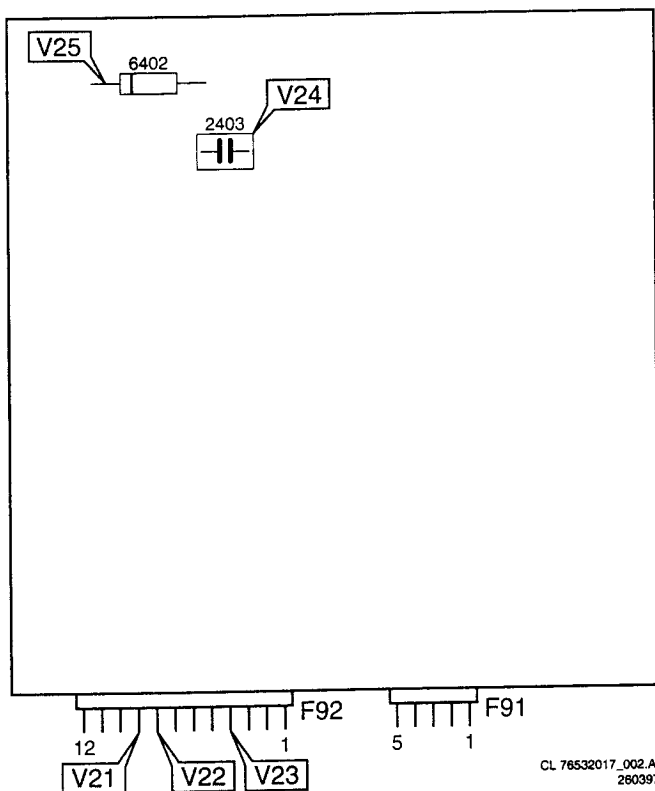

CL 76532017\_002.AI  
 260397

OSC\_L.AI  
 270397



2000.01	2000.02	2000.03	2000.04	2000.05	2000.06	2000.07	2000.08	2000.09	2000.10	2000.11	2000.12	2000.13	2000.14	2000.15	2000.16	2000.17	2000.18	2000.19	2000.20	2000.21	2000.22	2000.23	2000.24	2000.25	2000.26	2000.27	2000.28	2000.29	2000.30	2000.31	2000.32	2000.33	2000.34	2000.35	2000.36	2000.37	2000.38	2000.39	2000.40	2000.41	2000.42	2000.43	2000.44	2000.45	2000.46	2000.47	2000.48	2000.49	2000.50	2000.51	2000.52	2000.53	2000.54	2000.55	2000.56	2000.57	2000.58	2000.59	2000.60	2000.61	2000.62	2000.63	2000.64	2000.65	2000.66	2000.67	2000.68	2000.69	2000.70	2000.71	2000.72	2000.73	2000.74	2000.75	2000.76	2000.77	2000.78	2000.79	2000.80	2000.81	2000.82	2000.83	2000.84	2000.85	2000.86	2000.87	2000.88	2000.89	2000.90	2000.91	2000.92	2000.93	2000.94	2000.95	2000.96	2000.97	2000.98	2000.99	2000.100
---------	---------	---------	---------	---------	---------	---------	---------	---------	---------	---------	---------	---------	---------	---------	---------	---------	---------	---------	---------	---------	---------	---------	---------	---------	---------	---------	---------	---------	---------	---------	---------	---------	---------	---------	---------	---------	---------	---------	---------	---------	---------	---------	---------	---------	---------	---------	---------	---------	---------	---------	---------	---------	---------	---------	---------	---------	---------	---------	---------	---------	---------	---------	---------	---------	---------	---------	---------	---------	---------	---------	---------	---------	---------	---------	---------	---------	---------	---------	---------	---------	---------	---------	---------	---------	---------	---------	---------	---------	---------	---------	---------	---------	---------	---------	---------	---------	---------	---------	----------

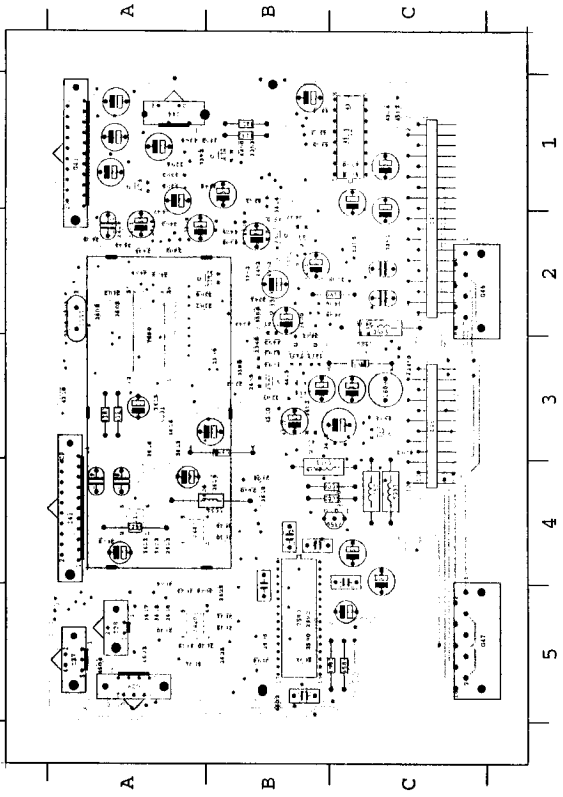

2000.01	2000.02	2000.03	2000.04	2000.05	2000.06	2000.07	2000.08	2000.09	2000.10	2000.11	2000.12	2000.13	2000.14	2000.15	2000.16	2000.17	2000.18	2000.19	2000.20	2000.21	2000.22	2000.23	2000.24	2000.25	2000.26	2000.27	2000.28	2000.29	2000.30	2000.31	2000.32	2000.33	2000.34	2000.35	2000.36	2000.37	2000.38	2000.39	2000.40	2000.41	2000.42	2000.43	2000.44	2000.45	2000.46	2000.47	2000.48	2000.49	2000.50	2000.51	2000.52	2000.53	2000.54	2000.55	2000.56	2000.57	2000.58	2000.59	2000.60	2000.61	2000.62	2000.63	2000.64	2000.65	2000.66	2000.67	2000.68	2000.69	2000.70	2000.71	2000.72	2000.73	2000.74	2000.75	2000.76	2000.77	2000.78	2000.79	2000.80	2000.81	2000.82	2000.83	2000.84	2000.85	2000.86	2000.87	2000.88	2000.89	2000.90	2000.91	2000.92	2000.93	2000.94	2000.95	2000.96	2000.97	2000.98	2000.99	2000.100
---------	---------	---------	---------	---------	---------	---------	---------	---------	---------	---------	---------	---------	---------	---------	---------	---------	---------	---------	---------	---------	---------	---------	---------	---------	---------	---------	---------	---------	---------	---------	---------	---------	---------	---------	---------	---------	---------	---------	---------	---------	---------	---------	---------	---------	---------	---------	---------	---------	---------	---------	---------	---------	---------	---------	---------	---------	---------	---------	---------	---------	---------	---------	---------	---------	---------	---------	---------	---------	---------	---------	---------	---------	---------	---------	---------	---------	---------	---------	---------	---------	---------	---------	---------	---------	---------	---------	---------	---------	---------	---------	---------	---------	---------	---------	---------	---------	---------	---------	----------

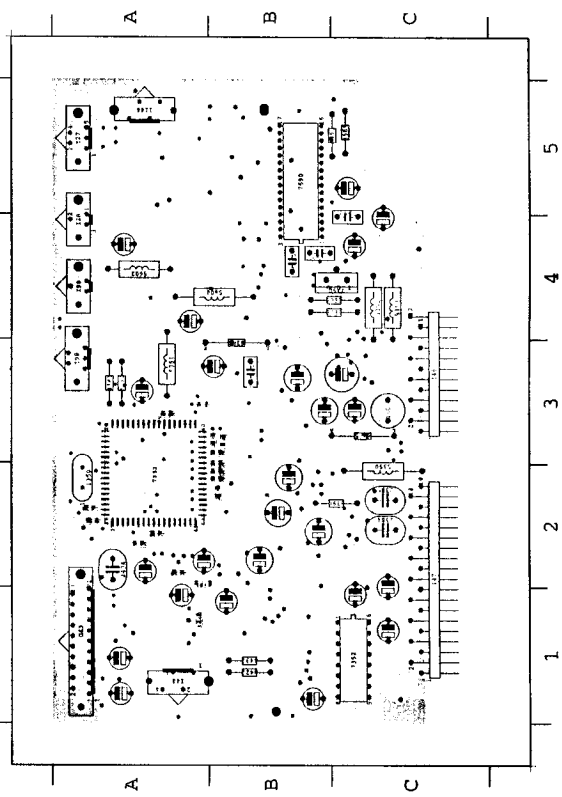









For Service Manuals Contact  
MAURITRON TECHNICAL SERVICES  
8 Cherry Tree Rd, Chinnor  
Oxon OX9 4QY  
Tel:- 01844-351694 Fax:- 01844-352554  
Email:- enquiries@mauritron.co.uk

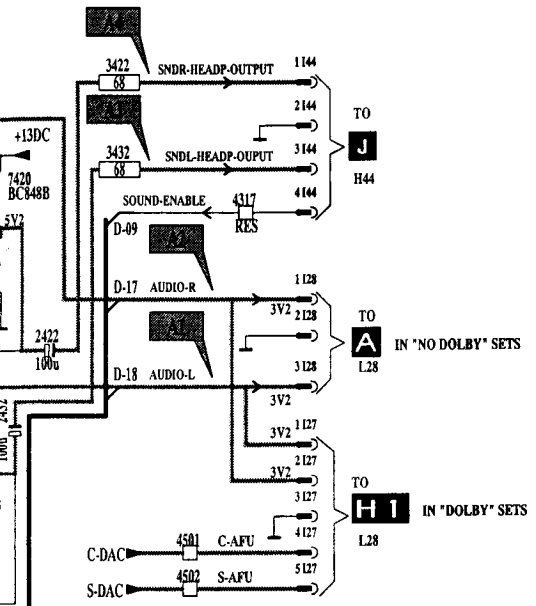

7600

SA7710T

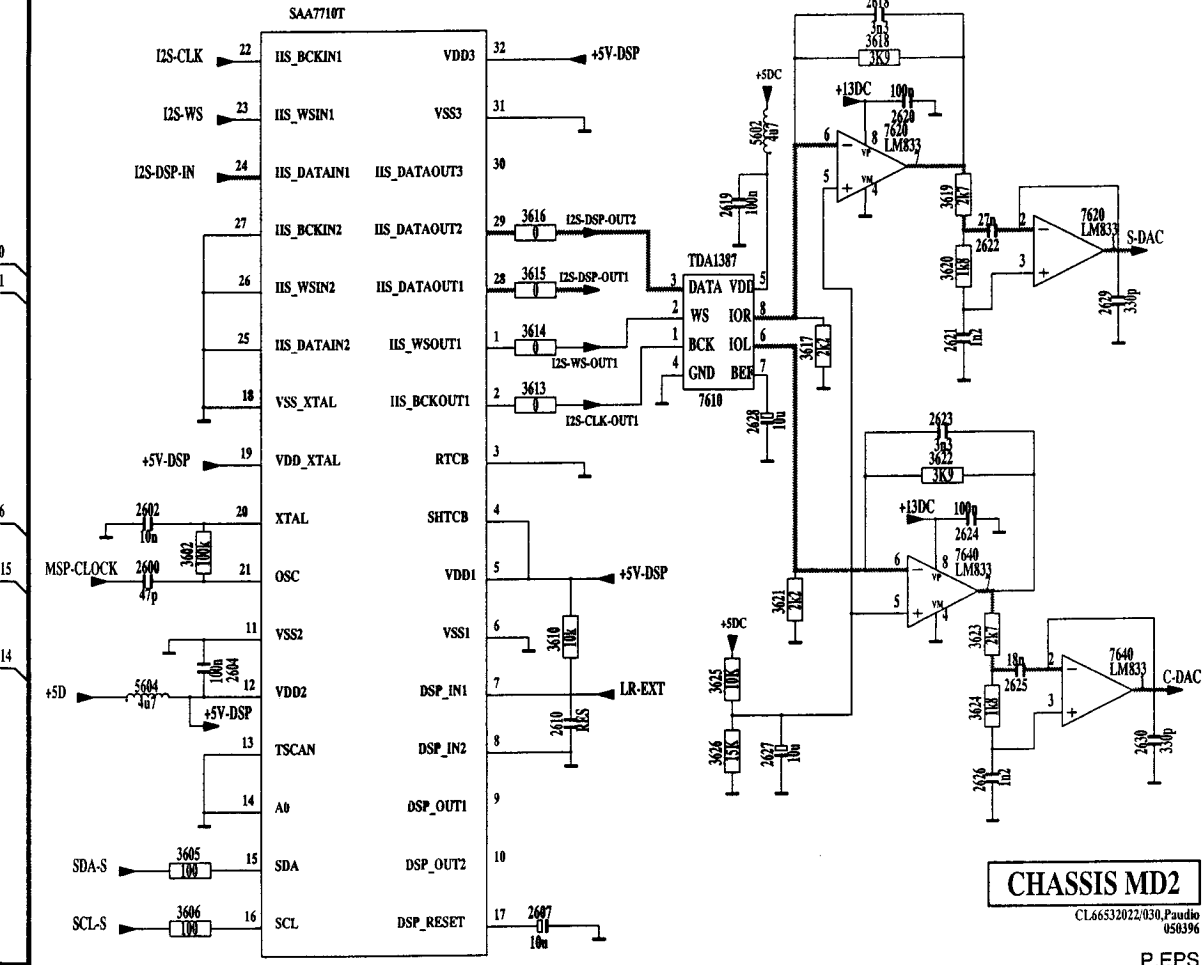

CHASSIS MD2  
CL66532022/030, Paudie  
050396  
P.EPS

A  
B  
C  
D  
E  
F  
G  
H  
I  
J  
K

0022	B 3	3520	B 2	3582	G 3	6601	G 3	A004	G 3	A006	B 3	A012	H 4	A016	F 5	K41	G 6
1600	C 1	3521	B 2	3584	G 2	A001	D 4	A005	G 2	A003	A 5	A013	E 5	A017	F 6	K42	G 6
2601	D 4	3500	D 5	3585	H 4	A002	A 5	A006	D 3	A010	A 2	A014	F 6	A018	A 6	V1	B 3
2604	G 5	3501	E 4	3586	H 2	A003	H 2	A007	C 3	A011	B 3	A015	F 5	A019	B 2	V2	B 3

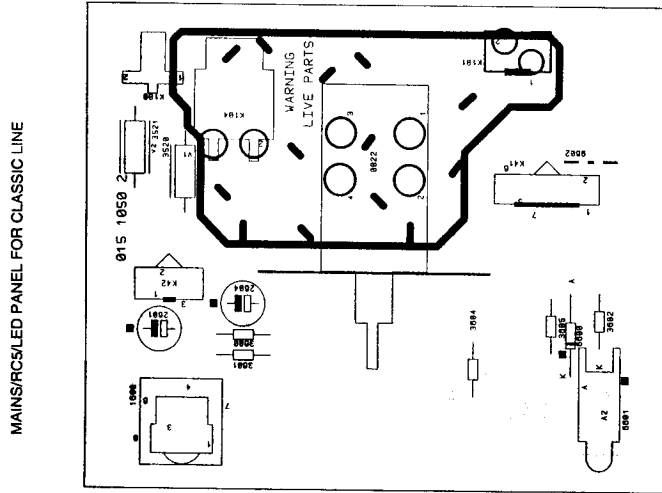
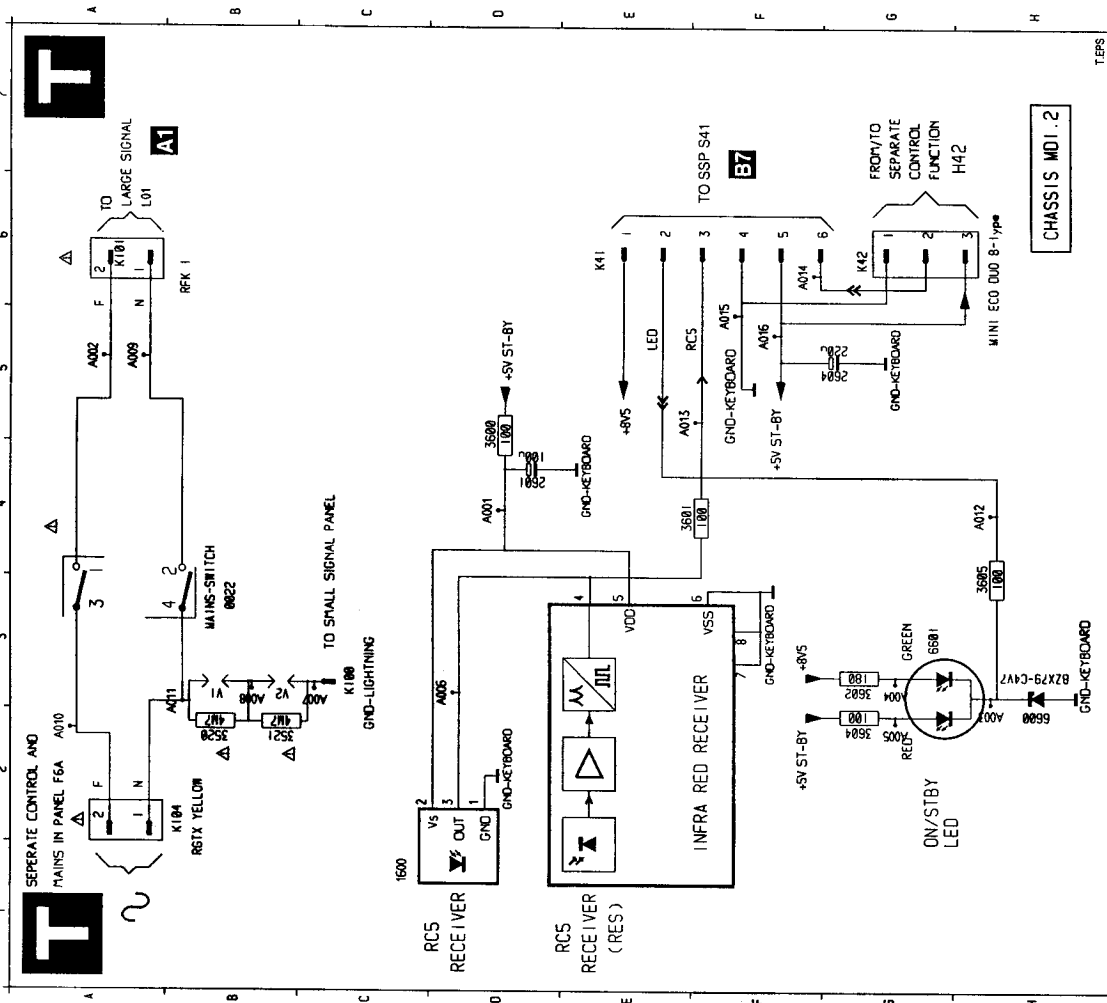

For Service Manuals Contact  
**MAURITRON TECHNICAL SERVICES**  
 8 Cherry Tree Rd, Chinnor  
 Oxon OX9 4QY  
 Tel:- 01844-351694 Fax:- 01844-352554  
 Email:- enquiries@maurtron.co.uk

## 8. Alignments

See Service Manual MD1.2E AA for a description of the basic alignments for the MD1.2E AA software.

Software version:  
M12BAx-4.x  
M12COx-3.2  
M12COx-4.0  
M12COx-3.2

4:3 sets (NO flashing LED procedure, replaced by M12COx-4.0)  
4:3 sets (WITH flashing LED procedure, replaces M12COx-3.2)

In the Service Default and Service Alignment Mode widescreen sets switch to WideScreen format. All the geometry alignments also have to be made in the WideScreen mode.

In this supplement the additional options for 16:9 and Dolby Pro Logic sets with the following software are described:

M12COx-5.1  
M12DOx-1.0  
(or later)  
16:9 sets (also suitable for 4:3 sets)  
Dolby Pro Logic sets (4:3 and 16:9)

### 8.1 Options and alignments

HI Histogram option. This option is not used and is not selectable.  
WB Format detection for 4:3, 14:9 or 16:9 picture (16:9 sets only) and Dolby Pro Logic sound (Dolby Pro Logic sets only) by the teletext IC.  
Y Automatic detection on  
N Automatic detection off  
Automatic 16:9 detection via the Scart cable also functions if 'WB N' is set.  
Picture tube aspect ratio  
Y 16:9 picture tube  
N 4:3 picture tube  
If '16 N' is set, parameters 'WB', 'RT', 'SS', 'D1', 'D3' and 'D4' automatically become blue and are made non-selectable.

\* In Dolby Pro Logic sets the WB option can be selected independently of the 16 option, as the automatic sound detection can also be switched on and off in this manner.

RT Rotation coil (picture tilt)  
Y Rotation coil present; An option to tilt the picture appears under the YELLOW key in the operating menu.  
N No rotation coil present.

D1 HD-value deviation in 4:3, Zoom 14:9 and Zoom 16:9 in relation to WideScreen mode.

D2 HD-value deviation in SuperWide (panorama) format in relation to WideScreen mode.

## Supplement MD1.2E 14

D3 HP-value deviation in 4:3, Zoom 14:9 and Zoom 16:9 in relation to WideScreen mode.

D4 HP-value deviation in SuperWide (panorama) format in relation to WideScreen mode.

The alignment settings are dependent on picture tube format:

Picture tube format	20"	24"	28"	32"
D1	12	9	9	8
D2	2	3	3	5
D3	10	9	9	8
D4	7	9	9	8

SS Picture dimension and rotation coil dependent setting.

SS	Picture tube / rotation coil
1	32" with rotation coil
2	28" with rotation coil
3	24" with rotation coil
4	32" without rotation coil
5	28" without rotation coil
6	24" without rotation coil

## 9. Circuit description

16:9 Module circuit description

4 functions are located on the 16:9 module:

- Blanking line and frame
- Picture rotation
- Panorama mode
- Line DC shift

IC 7440 (fC control of functions) controls the picture rotation, panorama mode switching and the blanking enable signal.

### 9.1 Line and frame blanking (Fig. 9.1 & 9.2)

#### 9.1.1 Line blanking (Horizontal blanking)

Horizontal blanking is used to completely blank-out the left and right bars in case of 4:3 or 14:9 view-mode. This is realised by making a wider fast blanking pulse FBI (signal A). This wider pulse is created by starting the pulse earlier (indicated by extra pulse-width '3') and delaying the pulse stop (indicated by a additional pulse '2'). The delay on the blanking pulse (time slot '2') causes blanking at the left side of the picture, the earlier start of pulses causes blanking at the right side of the picture. The corrected (= widened) FBI pulse is supplied to the video controller pin 24 IC7119-4C that controls the blanking of the RGB-outputs.

A 0V at the 'BLANKING 16:9' line (connector F92-4) blanks the video signal. This is the case when TS7405 is conducting.

#### 9.1.1.1 Blanking during the normal sandcastle pulse (1)

During the normal sandcastle pulse the picture has to be blanked; if the base of TS7420 is high (sandcastle present), TS7420 and TS7402 are conducting. In this way the collector of TS7403 is connected to ground by D6401. This will force TS7404 out of conduction and TS7405 in conduction. If TS7405 is conducting the picture will be blanked.

#### 9.1.1.2 Blanking the left side of the picture (2)

To blank the left side of the picture, the sandcastle pulse has to be present longer. If TS7402 is conducting, C2404 is discharged (resetted). If the sandcastle pulse at the base of TS7420 is gone, TS7402 will block and C2404 is charged via R3413, R3449 and R3450. This will create a sawtooth shaped voltage over C2404. This Voltage is also present at the collector of TS7403. The picture is blanked till the voltage on the collector of TS7404 is 0V7 higher than the voltage on the emitter of TS7404. During the time that TS7404 is out of conduction the picture is blanked. By regulating the voltage on the emitter of TS7404 with R3409 (if present), the time to blank the left-side of the picture can be adjust.

### 9.1.1.3 Blanking the right side of the picture (3)

To blank the right of the picture, the sandcastle pulse has to start earlier; Because the positive charged side of C2403 (the side connected to C2404) is connected to ground, the sawtooth on point B is shifted to a negative voltage. Now the voltage on the negative point (C) will increase (following point B). This goes on until the voltage on point C is 0V7.

Then TS7403 starts to conduct and TS7404 will block; the picture will be blanked. So prior to the normal sandcastle pulse, point C exceeds the 0V7 and starts to blank the picture.

### 9.1.2 Frame-blanking (vertical blanking)

Vertical blanking is used to avoid vertical overscan (scanning against the top and bottom of the CRT, outside the visible area) in 14:9 and 16:9 WIDESCREEN view-mode. Scanning outside the visible area should be avoided since it influences the EHT-INFO (and thus white limiting), leading to unwanted contrast reduction. It can even lead to EHT-losses (line output stage loaded to heavy) and röntgen-radiation. The vertical blanking is controlled by the sawtooth on pin 8F92. This sawtooth is symmetrical around 0V. The value of the sawtooth is shifted between 0V and 1V4 by capacitor C2406. In normal conditions (writing of the picture) TS7406 and TS7409 are conducting. This will cause a voltage drop over R3423 and force TS7411 in conduction. This will bring TS7410 and TS7404 in conduction. No blanking will take place at this moment because the base of TS7405 is 'low'. If the sawtooth voltage becomes very high or very low TS7409 or TS7406 are driven out of conduction. If the sawtooth voltage is higher than the emitter-voltage of TS7409, TS7409 is blocked. Consequently, there is no voltage drop across R3424 and TS7411 is out of conduction. TS7410 and TS7404 are also out of conduction. Now the base of TS7405 is supplied by R3417; TS7405 goes in conduction, resulting in blanking of the picture.

## 9.2 Frame rotation

To compensate the frame rotation caused by the earth magnetism, a frame rotation circuitry can be applied. The circuitry compensates the earth magnetism with an equal but opposite magnetic force. For this purpose a coil is fitted to the picture tube through which a current flows; the strength and direction of this current is adjustable. This circuitry is situated on the 16:9 module around IC 7440 and the circuitry with TS7401, TS7407, TS7408 and TS7412.

Operation

IC7440 is an I/O-expander. Left or right tilting is realised by driving TS7407 (and thus TS7408) or TS7412 (and thus TS7401) (more or less) into conduction. Combinations of driving both TS7407 and TS7412 are also possible.

In total there are 9 states:

The other 7 states of the 16 states true table are not valid as they do not give other correction states:

- 0000 = 0101 = 1010 = 1111 → 0101, 1010 and 1111 not used
- 1110 = 0100 et 1101 = 1000 → 1110 and 1101 not used
- 1011 = 0001 et 0111 = 0010 → 1011 and 0111 not used

Side A or B represent an upward correction on the left or right side of the picture (direction depends on the polarity of the deflection coil).

A	B	C	D	Correction
0	0	0	0	No correction at all
0	1	0	0	Small correction to side A
1	0	0	0	Medium correction to side A
1	1	0	0	High correction to side A
0	0	0	1	Small correction to side B
0	0	1	0	Medium correction to side B
0	0	1	1	High correction to side B
0	1	1	0	Small correction to side A corrected by medium correction to side B, so in total a very small correction to side B (smaller than at 0001)
1	0	0	1	Medium correction to side A corrected by small correction to side B, so in total a very small correction to side A (smaller than at 0100)

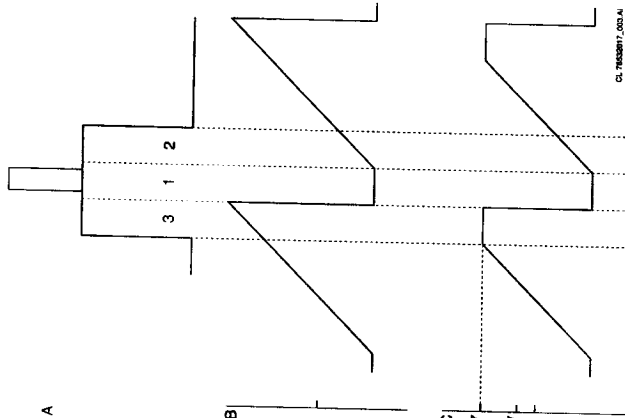

Fig. 9.1

9.3 Panorama mode

An additional capacitor (C2400) is added to the diode modulator by thyristor 6406. This is controlled by transistor TS7400 which is controlled by the I/O expander. In this way the S-correction can be installed. In SUPERWIDE mode C2400 is disconnected from the diode-modulator. This results in more deflection at the edges of the screen than in the middle of the screen.

When transistor TS7400 is conducting, T6406 can not be triggered. This means that C2400 is not added to the diode modulator. When flyback takes place, a part of the flyback-pulse is present at the gate of the thyristor. This will trigger the thyristor and C2400 is added to the diode modulator. During the first part of the line scan the thyristor is conducting. In the second part of the scan, the current changes direction and C2400 is added to the diode modulator by diode 6410.

9.4 DC-shift

In case of bad centring of the picture, a DC-current can be injected in the line network through LS402. The direction of the current can be chosen by connecting pin 2F90 to 3F90 or to 1F90. If this is not enough, an extra DC shift module can be added on connector F94.

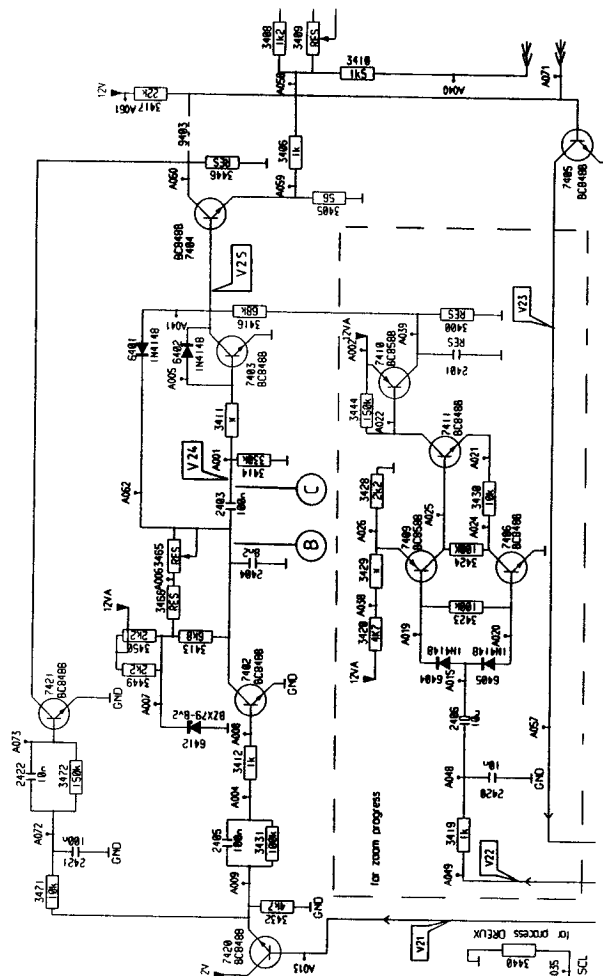
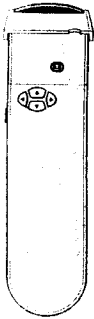

Fig. 9.2





## 16/9 Function

The pictures you receive may be transmitted in 16:9 format (wide screen) or 4:3 format (conventional screen). 4:3 pictures sometimes have a black band at the top and bottom of the screen (letterbox format). This function allows you to optimise the picture display on screen.

### Automatic switching

This TV set is also equipped with automatic switching which will select the correct-screen format, provided the specific signals are transmitted with the programmes.

*This automatic format can also be modified manually.*

## Using the different screen formats

Press the  $\odot$  keys to select the different modes:

4:3, ZOOM 14:9, ZOOM 16:9, SUBTITLE ZOOM, SUPER ZOOM and WIDE SCREEN.

*These settings may also be accessed using the  $\odot$  key under the flap on your remote control.*

### 4:3 Mode

The picture is reproduced in 4:3 format and a black band is displayed on either side of the picture. The picture may be progressively enlarged using the  $\odot$  keys.



4:3 Picture

### ZOOM 14:9 Mode

The picture is enlarged to 14:9 format, a thin black band remains on both sides of the picture. The  $\odot$  keys allow you to increase or decrease the section at the bottom of the picture where sub-titles may be displayed.

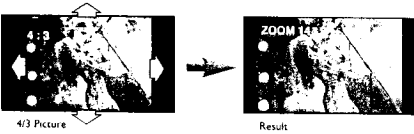

4:3 Picture

Result

### ZOOM 16:9 Mode

The picture is enlarged to 16:9 format. This mode is recommended when displaying pictures which have black bands at the top and bottom (letterbox format). Use the  $\odot$  keys if you wish to display sub-titles.

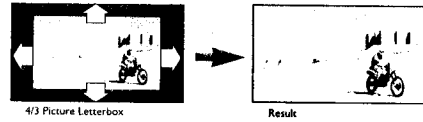

4:3 Picture Letterbox

Result

### SUBTITLE ZOOM Mode

This mode is used to display 4:3 pictures using the full surface of the screen leaving the sub-titles visible. Use the  $\odot$  keys to increase or decrease the section at the bottom of the picture.

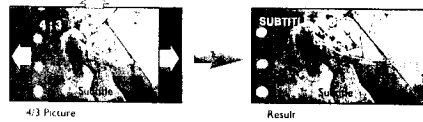

4:3 Picture

Result

### SUPER ZOOM Mode

This mode is used to display 4:3 pictures using the full surface of the screen by enlarging the sides of the picture.

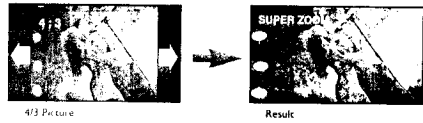

4:3 Picture

Result

### WIDE SCREEN Mode

This mode restores the correct proportions of pictures transmitted in 16:9 using full screen display.

*Note: If you display a 4:3 picture in this mode, it will be enlarged horizontally.*

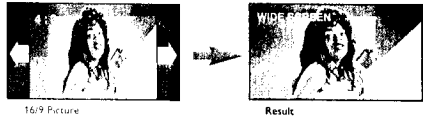

16:9 Picture

Result

## Sound

Press the green  $\odot$  key to display the SOUND menu.

### Sound mode

This menu allows you to select the different Dolby Surround modes.

1 Select SOUND MODE (the  $\odot$  keys) and press the  $\odot$  key. The SOUND MODE menu appears.

2 Use the  $\odot$  keys to select the NORMAL, DOLBY PRO LOGIC, DOLBY 3 STEREO or HALL SURROUND sound modes.

For each setting, the active loudspeakers are displayed on screen.

#### Normal

The left (L) and right (R) channels are reproduced on the left and right loudspeakers of the TV set.

**Dolby Pro Logic\*** (with Dolby Surround sound sources)

As well as the left (L) and right (R) channels, a centre channel (C) and a rear channel comprising 2 loudspeakers (S), reproduce the Dolby Pro Logic sound.

This mode is used when a film or programme has been recorded or encoded in Dolby Surround sound. These films or programmes are always indicated by the symbol  $\square$  [DOLBY SURROUND].

**Dolby 3 Stereo** (with Stereo sources)

Dolby 3 Stereo sound is produced only on the left (L), right (R) and centre (C) channels.

**Hall Surround** (with mono or Stereo sources)

The left (L) and right (R) channels are reproduced on the left and right loudspeakers of the TV set and on the rear channel (S), creating a "Hall Surround" ambient effect.

This mode is recommended for broadcasts that are not encoded in Dolby Surround if you wish to use a rear channel.

To exit from the menu: Press the blue  $\odot$  key.

*Dolby Pro Logic and Dolby 3 Stereo modes are not recommended for mono transmissions (only the central channel is used).*

### Sound level

This menu is used to balance the volume between the loudspeakers.

1 Select SOUND LEVEL (the  $\odot$  keys) and press the  $\odot$  key. The SOUND LEVEL menu appears.

2 Select TEST (the  $\odot$  keys) and press the  $\odot$  key. A continuous sound is emitted in turn from each channel: left, right, centre and rear channel.

3 Use the  $\odot$  keys to adjust the level of each channel independently: BALANCE, CENTRE and REAR. The sequence stops while the level is being changed and then automatically starts up again.

To stop the test: Press the blue  $\odot$  key.

*Levels may also be adjusted without using the test signal.*

\* Manufactured under license from Dolby Laboratories Licensing Corporation. "Dolby" "Pro Logic" and the double D symbol  $\square$  are trademarks of Dolby Laboratories Licensing Corporation.

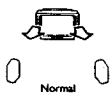

Normal

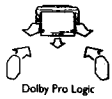

Dolby Pro Logic

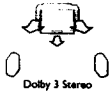

Dolby 3 Stereo



Hall Surround

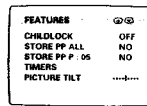
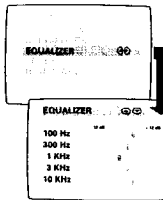
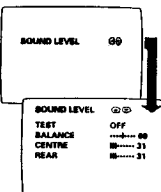

### Equalizer

1 Select EQUALIZER (the  $\odot$  keys) and press the  $\odot$  key.

The EQUALIZER menu appears.

2 Use the  $\odot$  keys to select each frequency (from bass: 100 Hz to treble: 10 kHz)

3 Use the  $\odot$  keys to adjust the level.

To exit from the menu: Press the blue  $\odot$  key.

### Spatial

This setting increased the stereo effect giving the impression that the loudspeakers are spaced further apart.

### Headphones

This setting allows the volume of the headphones to be adjusted independently from the TV set.

To exit from the menu: Press the blue  $\odot$  key.

## Features

### Child Lock

The child lock function is an electronic lock which disables the keys on the TV set.

1 Display the FEATURES menu (yellow  $\odot$  key).

2 Select CHILD LOCK (the  $\odot$  keys).

3 Use  $\odot$  keys to switch to ON.

4 Switch off the TV set and remove the remote control. The television can no longer be used.

The TV set can only be switched on using the remote control.

To cancel: Return CHILD LOCK to OFF in the features menu.

### Storing adjustments

This function allows you to store your own picture and sound adjustments. The adjustments are restored every time your set is switched on, or by pressing the green  $\odot$  key on your remote control.

### General storing

1 First carry out your PICTURE and SOUND adjustments and adjust the volume ( $\leftarrow$  key) then:

2 Display the FEATURES menu (yellow  $\odot$  key).

3 Select STORE PP ALL (the  $\odot$  keys) and press  $\odot$ .

The message OK appears. All the PICTURE and SOUND menu adjustments as well as the volume are stored.

**Storing adjustments for each programme**

This function allows you to correct any differences in levels which may exist between TV channels and/or EXT sockets. It allows you to store BRIGHTNESS, COLOUR, SHARPNESS, NOISE REDUCT, SOUND MODE and volume adjustments (←→ key).

- 1 Carry out desired corrections to settings for the programme (or EXT connection), and then:
- 2 Display the FEATURES menu (yellow 0 key).
- 3 Select STORE PP P: \_ \_ (⊖ ⊕ keys) and press . The message OK appears. The adjustments are stored. Repeat for each programme that needs correcting.

**Programming**

**Sleeptimer**

From the FEATURES menu (yellow 0 key).

- 1 Select PROGRAMMING (⊖ ⊕) and press . The PROGRAMMING menu appears.
- 2 Select SLEEPTIMER and use ⊕ to enter the length of time after which the TV will switch to standby mode (up to 180 mins). Press the ⊖ key to display the length of time remaining.

To cancel: Switch SLEEPTIMER back to 0.

**Programmed Switch on**

The following adjustments allow you to program the TV to automatically switch on with the programme of your choice. Select the adjustments using ⊖ ⊕ keys:

- 1 SET CLOCK: Use keys 0 to 9 or the ⊕ ⊖ keys. NB: Every time the TV is switched on the clock is automatically updated on the basis of the teletext information in programme No. 1. If the TV set does not feature teletext, this update will not occur.
- 2 START TIME: Use keys 0 to 9 or ⊕ ⊖ keys.
- 3 STOP TIME: Use keys 0 to 9 or ⊕ ⊖ keys.
- 4 PRG NUMBER: Use keys 0 to 9 or ⊕ ⊖ keys.
- 5 DAILY: Set this option to ON ( key) if you want the programming to apply every day.
- 6 TIMER ACTIVE Set this option to ON to activate the timer.

Press the blue 0 key to exit from menu. If you now switch the TV set onto standby (0 key), it will automatically switch on at the time programmed.

To cancel: Switch TIMER ACTIVE back to OFF.

NB: For programming to function correctly do not use the on/off key on the front of the TV set to switch off the TV.

The programmed switch on-off can be used together with the child lock function in order to limit the use of the TV set to a certain length of time.

**Picture tilt (only on certain models)**

Select PICTURE TILT using the ⊖ ⊕ keys and use the ⊕ ⊖ key to adjust the tilt of the picture.

This compensates for regional variations in the earth's magnetic field.

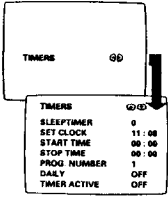

**Connecting peripheral equipment**

The EXT1 socket has audio and video inputs/outputs and RGB inputs. The EXT2 socket has audio and video inputs/outputs and S-VHS inputs. For further information, see glossary (p. 22).

**Video recorder**

**...with Decoder**

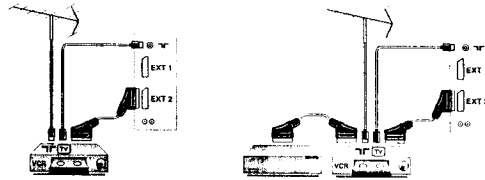

- If your video recorder has a euroconnector socket, carry out the above connections. Euroconnector sockets ensure better picture quality.
- If your video recorder does not have a euroconnector socket (or if this is already being used by another device), then the only connection possible is via the aerial cable. Your video recorder is then considered as a TV programme by your TV set. You will therefore need to tune in your video recorder's test signal and assign it programme number 0 (see manual store chapter, p. 5). To reproduce the video recorder picture, press the 0 key. Refer to your video recorder's operating instructions concerning the test signal (the video recorder must be equipped with an HF modulator).

**Connecting other equipment**

(satellite receiver, decoder, CDV/CDI, games...)

Connect to socket EXT1 (or to EXT2 if it produces a S-VHS signals).

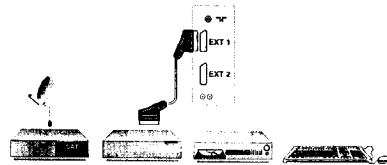

**To select connected equipment**

Use ⊖ ⊕ key to select E1 (EXT1), E2 (EXT2) or, for S-VHS or Hi-8 equipment, E2 Y/C. Most equipment (decoder, video recorder) carries out the switchover itself.

**Front connections**

Carry out one of the following connections and then: Use the ⊖ ⊕ key to select E2 (for VHS or 8mm cameras) or E2 Y/C (S-VHS or Hi-8 cameras). NB: If a peripheral is connected to EXT2, it is advisable to switch it off while using a front S-VHS connection.

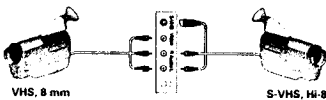

**Headphones**

To adjust the headphones volume, use the HEADPHONES adjustment in the SOUND menu (p. 14). To adjust the volume on the TV set, use the ←→ or ⊖ ⊕ keys. You can also access the HEADPHONES adjustment directly using programmable keys ⊖ ⊕ and ⊖ ⊕ on the remote control (see p. 8).

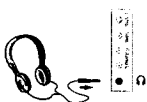

**Amplifier**

Use an audio connection cable and connect the ⊖ ⊕ sockets "L" and "R" on the set to the "AUDIO IN" "L" and "R" input on your hi-fi amplifier.

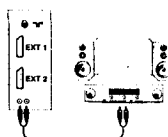

**External loudspeakers**

For improved sound, you can connect 2 external L and R loudspeakers in the place of the left and right loudspeakers on the TV set. Connect as shown below and then switch off the internal loudspeakers on the TV set. The impedance of the loudspeakers must be between 8 and 16 Ohms.

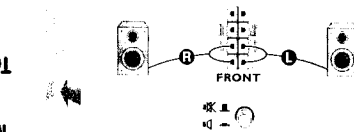

**Surround loudspeakers**

Connect the 2 Surround loudspeakers as illustrated below. The loudspeakers should be located at the rear or on either side of the listening zone (always connect 2 loudspeakers).

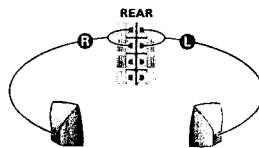

**To make a copy of recordings:**

Carry out one of the following connections, then: Press ⊖ ⊕ to select E1. On the video recorder, select the euroconnector socket as the recording source. NB: Copying is not possible using front connections.

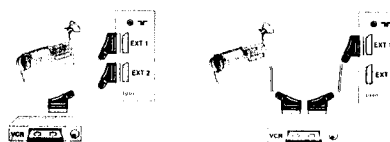

For Service Manuals Contact  
MAURITRON TECHNICAL SERVICES  
8 Cherry Tree Rd, Chinnor  
Oxon OX9 4QY  
Email: enquiries@mauratron.co.uk  
Tel: 01844 351694 Fax: 01844 352564

# 11. List of abbreviations /

(not covered in CM MD1.2E)

<b>GB</b>	<b>DBE</b>	Left channel audio signal coming from Audio Module via LSP.
	<b>AUDIO-L</b>	Right channel audio signal coming from Audio Module via LSP.
	<b>AUDIO-R</b>	Switching signal to enable or disable Dynamic Bass Enhancement (DBE). When external front speakers are selected (on the clickfit panel), DBE is bypassed.
	<b>L-DBE</b>	Left channel audio signal with additional amplification of 80Hz signals.
	<b>R-DBE</b>	Right channel audio signal with additional amplification of 80Hz signals.
		Going from DBE module to LSP audio amplifier.
		additional amplification of 80Hz signals.
		Going from DBE module to LSP audio amplifier.

<b>(NL)</b>	<b>DBE</b>	Audiosignaal linker kanaal, afkomstig van Audio Module via LSP.
	<b>AUDIO-L</b>	Audiosignaal rechter kanaal, afkomstig van Audio Module via LSP.
	<b>AUDIO-R</b>	Schakelingsignaal waarmee versterking laagveerige (DBE) kan worden in- of uitgeschakeld. Wanneer externe luidsprekers aan de voorzijde worden geselecteerd (op het clickfit paneel), wordt DBE overbrugd.
	<b>L-DBE</b>	Audiosignaal linker kanaal met extra versterking van 80Hz signalen. Van DBE module naar LSP audio versterker.
	<b>R-DBE</b>	Audiosignaal rechter kanaal met extra versterking van 80Hz signalen. Van DBE module naar LSP audio versterker.

<b>(D)</b>	<b>DBE</b>	Audiosignaal für den linken Kanal, kommt über die GSP vom Audio-Modul.
	<b>AUDIO-L</b>	Audiosignaal für den rechten Kanal, kommt über die GSP vom Audio-Modul.
	<b>AUDIO-R</b>	Schaltensignal zum Ein- bzw. Ausschalten der dynamischen Triefenverbesserung (Dynamic Bass Enhancement - DBE). Bei der Wahl von externen Frontlautsprechern (auf der Clickfit-Platine) wird DBE überbrückt.
	<b>L-DBE</b>	Audiosignaal für den linken Kanal mit zusätzlicher Verstärkung der 80-Hz-Signale. Läuft vom DBE-Modul zum Audioverstärker auf der GSP.
	<b>R-DBE</b>	Audiosignaal für den rechten Kanal mit zusätzlicher Verstärkung der 80-Hz-Signale. Läuft vom DBE-Modul zum Audioverstärker auf der GSP.

# Supplement MD1.2E 18

# Liste der Abkürzungen / Liste des abreviations

<b>16:9 MODULE</b>	<b>F</b>	<b>DBE</b>	130V supply voltage from LOT to DC-shift circuitry.
<b>130VLOT</b>		<b>AUDIO-L</b>	150V supply voltage from LOT to DC-shift circuitry.
<b>150VLOT</b>		<b>AUDIO-R</b>	Fast blanking signal to video controller IC7119-4C, corrected for both additional horizontal and vertical blanking in 14:9 and 16:9 modes.
<b>BLANKING 16:9</b>		<b>DBE-COMMAND</b>	Correction signal from the 16:9 module back to the frame output stage.
<b>FRAMEDEFL-R</b>			Original line deflection signal from line output stage to the 16:9 module.
<b>LINEDEFL-LIN</b>		<b>L-DBE</b>	140V supply voltage from LOT to DC shift circuitry.
<b>VOCONN</b>		<b>R-DBE</b>	

<b>16:9 MODULE</b>	<b>(I)</b>	<b>DBE</b>	130V voedingsspanning van de LOT naar het DC-shift-systeem.
<b>130VLOT</b>		<b>AUDIO-L</b>	150V voedingsspanning van de LOT naar het DC-shift-systeem.
<b>150VLOT</b>		<b>AUDIO-R</b>	Signaal snelle onderdrukking naar video controller IC7119-4C, met correctie extra lijn- en rasteronderdrukking in 14:9 en 16:9 mode.
<b>BLANKING 16:9</b>		<b>DBE-COMMAND</b>	Correctiesignaal van de 16:9 module terug naar de rasterendtrap.
<b>FRAMEDEFL-R</b>			Corspronkelijk lijnblauwsignaal van de lineindtrap naar de 16:9 module.
<b>LINEDEFL-LIN</b>		<b>L-DBE</b>	140V voedingsspanning van de LOT naar het DC-shift-systeem.
<b>VOCONN</b>		<b>R-DBE</b>	

<b>16:9-MODUL</b>	<b>(E)</b>	<b>DBE</b>	130-V-Speisespannung vom LOT zur Gleichstromverschiebungsschaltung.
<b>130VLOT</b>		<b>AUDIO-L</b>	150-V-Speisespannung vom LOT zur Gleichstromverschiebungsschaltung.
<b>150VLOT</b>		<b>AUDIO-R</b>	Austastsignal zum Bildregler IC7119-4C, bereits korrigiert auf zusätzliche Horizontal- und Vertikalaustastung in der 14:9- und 16:9-Betriebsart.
<b>BLANKING 16:9</b>		<b>DBE-COMMAND</b>	Korrektursignal vom 16:9-Modul zurück zur Vertikal-Ablenkendstufe.
<b>FRAMEDEFL-R</b>			Original Zeilenablenkungs-signal von der Zeilen-Ablenkendstufe zum 16:9-Modul.
<b>LINEDEFL-LIN</b>		<b>L-DBE</b>	140-V-Speisespannung vom LOT zur Gleichstromverschiebungsschaltung.
<b>VOCONN</b>		<b>R-DBE</b>	

<b>MODULE 16:9</b>	<b>130VLOT</b>	Tension d'alimentation 130V délivrée par le LOT (transformateur de sortie de ligne) au circuit de correction à courant continu.
	<b>150VLOT</b>	Tension d'alimentation 150V délivrée par le LOT (transformateur de sortie de ligne) au circuit de correction à courant continu.
	<b>BLANKING 16:9</b>	Signal de suppression rapide délivré au contrôleur vidéo IC7119-4C, additionné des deux suppressions supplémentaires, horizontale et verticale, en modes 14:9 et 16:9.
	<b>FRAMEDEFL-R</b>	Signal de correction envoyé par le module 16:9 à l'étage de sortie de lignes.
	<b>LINEDEFL-LIN</b>	Signal original de déviation horizontale délivré à l'étage de sortie de lignes au module 16:9.
	<b>VOCONN</b>	Tension d'alimentation 140V délivrée par le LOT (transformateur de sortie de ligne) au circuit de correction à courant continu.

<b>MODULO 16:9</b>	<b>130VLOT</b>	Segnale audio del canale sinistro proveniente dal modulo audio tramite ILSP.
	<b>150VLOT</b>	Segnale audio del canale destro proveniente dal modulo audio tramite ILSP.
	<b>BLANKING 16:9</b>	Segnale di commutazione per attivare o disattivare il Dynamic Bass Enhancement (DBE). Quando vengono selezionati gli attoparlanti esterni anteriori (sul pannello click-fit), DBE viene escluso.
	<b>FRAMEDEFL-R</b>	Segnale di commutazione dei segnali da 80Hz. Va dal modulo DBE all'amplificatore audio del LSP.
	<b>LINEDEFL-LIN</b>	Segnale audio del canale sinistro con ulteriore amplificazione dei segnali da 80Hz. Va dal modulo DBE all'amplificatore audio del LSP.
	<b>VOCONN</b>	

<b>MODULO 16:9</b>	<b>130VLOT</b>	Señal de audio del canal izquierdo procedente del Módulo Audio a través del LSP.
	<b>150VLOT</b>	Señal de audio del canal derecho procedente del Módulo Audio a través del LSP.
	<b>BLANKING 16:9</b>	Señal de conmutación para habilitar o deshabilitar la Mejora Dinámica de los Bajos (DBE). Habiendo sido seleccionados altavoces frontales externos (en el panel click-fit), DBE está puesta en deriva.
	<b>FRAMEDEFL-R</b>	Señal de conmutación para habilitar o deshabilitar la Mejora Dinámica de los Bajos (DBE). Habiendo sido seleccionados altavoces frontales externos (en el panel click-fit), DBE está puesta en deriva.
	<b>LINEDEFL-LIN</b>	Señal de conmutación para habilitar o deshabilitar la Mejora Dinámica de los Bajos (DBE). Habiendo sido seleccionados altavoces frontales externos (en el panel click-fit), DBE está puesta en deriva.
	<b>VOCONN</b>	Señal de audio del canal izquierdo con amplificación adicional de señales de 80Hz, suministrada por el módulo DBE al amplificador audio del LSP.
		Señal de audio del canal derecho con amplificación adicional de señales de 80Hz, suministrada por el módulo DBE al amplificador audio del panel LSP.





3753	4822 051 20101	100Ω 5% 0.1W
3754	4822 051 20101	100Ω 5% 0.1W
3755	4822 051 20223	22k 5% 0.1W
3756	4822 051 20272	2k7 5% 0.1W
3757	4822 051 20822	8k2 5% 0.1W
3758	4822 051 20104	100k 5% 0.1W
3759	4822 051 20683	68k 5% 0.1W
3761▲	4822 051 20332	3k3 5% 0.1W
3762▲	4822 051 20332	3k3 5% 0.1W

3764	4822 117 10833	10k 1% 0.1W
3765	4822 051 20104	100k 5% 0.1W
3766	4822 116 52175	100Ω 5% 0.5W
3767	4822 116 52175	100Ω 5% 0.5W
3769	4822 051 20471	470Ω 5% 0.1W
3769	4822 051 20561	560Ω 5% 0.1W
3770	4822 051 20104	100k 5% 0.1W
3770	4822 117 11149	82k 1% 0.1W
3771	4822 051 20471	470Ω 5% 0.1W
3771	4822 051 20561	560Ω 5% 0.1W

3772	4822 051 20393	39k 5% 0.1W
3772	4822 051 20473	47k 5% 0.1W
3773	4822 051 20563	56k 5% 0.1W
3774	4822 051 20563	56k 5% 0.1W
3775	4822 051 20682	6k8 5% 0.1W
3775	4822 051 20821	820Ω 5% 0.1W
3776	4822 051 20101	100Ω 5% 0.1W
3777	4822 116 52297	68k 5% 0.5W
3778	4822 051 10102	1k 5% 0.1W
3779▲	4822 051 20332	3k3 5% 0.1W

3780	4822 116 52213	180Ω 5% 0.5W
3782	4822 116 52213	180Ω 5% 0.5W
3784	4822 051 20471	470Ω 5% 0.1W
3784	4822 051 20561	560Ω 5% 0.1W
3785	4822 051 20104	100k 5% 0.1W
3785	4822 117 11149	82k 1% 0.1W
3786	4822 051 20471	470Ω 5% 0.1W
3786	4822 051 20561	560Ω 5% 0.1W
3787	4822 051 20393	39k 5% 0.1W
3787	4822 051 20473	47k 5% 0.1W

3788	4822 051 20563	56k 5% 0.1W
3789	4822 051 20563	56k 5% 0.1W
3790	4822 051 20682	6k8 5% 0.1W
3790	4822 051 20821	820Ω 5% 0.1W
3791	4822 051 20101	100Ω 5% 0.1W
3792	4822 116 52297	68k 5% 0.5W
3793	4822 051 10102	1k 5% 0.1W
3794▲	4822 051 20332	3k3 5% 0.1W
3795	4822 117 10833	10k 1% 0.1W
3796	4822 117 10833	10k 1% 0.1W

3798▲	4822 051 20332	3k3 5% 0.1W
3799▲	4822 051 20332	3k3 5% 0.1W



6775▲	4822 130 30621	1N4148
6790▲	4822 130 30621	1N4148



7770▲	5322 130 41982	BC848B
7771▲	5322 130 41982	BC848B
7772	4822 209 30095	LM833D
7773▲	5322 130 41982	BC848B
7774	5322 209 14481	HEF4053BT
7780▲	5322 130 41982	BC848B
7787	4822 209 30095	LM833D

**MAINS + FRONT CONTROL PANEL [J]**

**Various**

4822 212 10936	Control/Mains Panel
▲ 4822 276 13603	Mains switch
4822 267 31014	Headphone connector
4822 276 30422	Switch assy (3X)
▲ 4822 265 30389	Con. 2P (Fixed pin)
4822 265 31248	Con. 3P
4822 265 31245	Con. 4P (H44)
4822 265 31246	Con. 6P eco-duo 2.5
4822 265 31245	Con. 6p eco-duo 2.5
4822 265 41451	Con. 9P (H33)
▲ 4822 256 91766	Led holder
1600 4822 130 91478	IR receiver TFMK5360D



2601	4822 124 41584	100μF 20% 10V
2800	4822 124 41596	22μF 20% 50V
2801	4822 124 41596	22μF 20% 50V
2804	4822 126 13597	330pF 10% 500V
2805	4822 126 13597	330pF 10% 500V
2810	5322 121 42489	33nF 5% 250V
2811	4822 124 81029	100μF 20% 25V
2813	4822 124 40763	2.2μF 100 V
2832	4822 126 13597	330pF 10% 500V
2834	4822 126 13597	330pF 10% 500V
2840	4822 126 13599	3.3nF 10% 500V



3520▲	4822 053 21475	4M7 5% 0.5W
3521▲	4822 053 21475	4M7 5% 0.5W
3600	4822 116 52175	100Ω 5% 0.5W
3601	4822 050 11002	1k 1% 0.4W
3602	4822 116 52213	180Ω 5% 0.5W
3604	4822 116 52175	100Ω 5% 0.5W
3605	4822 116 52175	100Ω 5% 0.5W
3608	4822 116 52238	12k 5% 0.5W
3609	4822 116 52289	5k6 5% 0.5W
3610	4822 116 83883	470Ω 5% 0.5W
3611	4822 050 24702	4k7 1% 0.6W
3612	4822 116 52175	100Ω 5% 0.5W
3801	4822 116 52202	82Ω 5% 0.5W
3802	4822 116 52201	75Ω 5% 0.5W
3803	4822 116 52289	5k6 5% 0.5W
3804	4822 116 52289	5k6 5% 0.5W

3805	4822 116 83874	220k 5% 0.5W
3806	4822 116 83874	220k 5% 0.5W
3807	4822 116 52175	100Ω 5% 0.5W
3809	4822 116 52219	330Ω 5% 0.5W
3810	4822 116 52305	820k 5% 0.5W
3811	4822 116 83882	39k 5% 0.5W
3812	4822 116 83864	10k 5% 0.5W
3813	4822 116 52283	4k7 5% 0.5W
3830	4822 116 83864	10k 5% 0.5W
3840	4822 116 52257	22k 5% 0.5W

3842	4822 116 83864	10k 5% 0.5W
------	----------------	-------------



6600	4822 130 34174	BZX79-C4V7
6601	4822 209 72895	TLUV5320



7811▲	4822 130 44197	BC558B
7812▲	4822 130 44197	BC558B
7840	4822 130 40937	BC548B

**16X9 PANEL [L]**

**Various**

4822 212 10945	16x9 Panel (24")
4822 212 10946	16X9 Panel (28")
4822 212 10947	16X9 Panel (32")
4822 265 20509	Con. 2P grey
4822 264 40207	Con. 3P male BTB-WTB
▲ 4822 265 10429	Pin strip (F92)



2400	4822 121 42059	100nF 10% 400V
2401	4822 122 33175	2.2nF 20% 50V
2403	5322 121 42386	100nF 10% 63V
2404	4822 126 10525	8.2nF 10% 63V
2405	4822 126 13296	100nF 10% 16V
2406▲	4822 124 41579	10μF 20% 50V
2409▲	4822 124 40196	220μF 20% 16V
2410▲	5322 126 10223	4.7nF 10% 63V
2420▲	4822 122 33177	10nF 20% 50V
2424▲	4822 126 12944	47nF 10% 50V
2425▲	4822 126 12944	47nF 10% 50V
2426	4822 124 41643	100μF 20% 16V



3400	4822 051 20124	120k 5% 0.1W
3402	4822 050 11002	1k 1% 0.4W
3403	4822 116 52271	33k 5% 0.5W
3404	4822 116 52283	4k7 5% 0.5W
3405	4822 051 20569	56Ω 5% 0.1W
3406	4822 051 10102	1k 5% 0.1W
3407	4822 116 52234	100k 5% 0.5W
3408	4822 051 20122	1k2 5% 0.1W
3410	4822 116 52243	1k5 5% 0.5W
3411	4822 051 20822	8k2 5% 0.1W

3411	4822 117 11149	82k 1% 0.1W
3412	4822 050 11002	1k 1% 0.4W
3413	4822 051 20682	6k8 5% 0.1W
3414	4822 051 20334	330k 5% 0.1W
3415	4822 116 52238	12k 5% 0.5W
3416	4822 051 20683	68k 5% 0.1W
3417	4822 051 20223	22k 5% 0.1W
3418	4822 050 11002	1k 1% 0.4W
3419	4822 050 11002	1k 1% 0.4W
3420▲	4822 051 20472	4k7 5% 0.1W

3422	4822 116 52271	33k 5% 0.5W
3423	4822 051 20104	100k 5% 0.1W
3424	4822 051 20104	100k 5% 0.1W
3425	4822 051 20333	33k 5% 0.1W
3426	4822 051 20822	8k2 5% 0.1W
3427▲	4822 052 10479	47Ω 5% 0.33W
3428	4822 117 11449	2K2 1% 0.1W
3429▲	4822 051 20332	3k3 5% 0.1W
3429	4822 051 20682	6k8 5% 0.1W
3430	4822 117 10833	10k 1% 0.1W

3431	4822 051 20104	100k 5% 0.1W
3432▲	4822 051 20472	4k7 5% 0.1W
3433	4822 051 20822	8k2 5% 0.1W
3434	4822 116 52243	1k5 5% 0.5W
3435	4822 117 10353	150Ω 1% 0.1W
3436	4822 051 20333	33k 5% 0.1W
3437	4822 116 52283	4k7 5% 0.5W
3438	4822 116 52175	100Ω 5% 0.5W
3439	4822 116 52175	100Ω 5% 0.5W
3440	4822 051 20223	22k 5% 0.5W

3440	4822 051 20683	68k 5% 0.1W
3440	4822 117 10833	10k 1% 0.1W
3441	4822 050 11002	1k 1% 0.4W
3442	4822 051 20105	1M 5% 0.5W
3443	4822 117 11383	12k 1% 0.1W
3444	4822 051 20154	150k 5% 0.5W
3445	4822 116 52271	33k 5% 0.5W
3447	4822 051 10102	1k 2% 0.25W
3448▲	4822 051 20472	4k7 5% 0.1W
3449	4822 117 11449	2k2 1% 0.1W

3450	4822 117 11449	2k2 1% 0.1W
3451	4822 051 10102	1k 5% 0.1W
3452	4822 116 52257	22k 5% 0.5W



6401▲	4822 130 30621	1N4148
6402▲	4822 130 30621	1N4148
6403▲	4822 130 30621	1N4148
6404▲	4822 130 30621	1N4148
6405▲	4822 130 30621	1N4148
6406	4822 130 20299	P0102DA
6410▲	4822 130 42489	BYD33G
6411	4822 130 42488	BYD33D
6412	4822 130 34382	BZX79-C8V2
6420	4822 130 34233	BZX79-C5V1



7400	4822 130 41782	BF422
7401	5322 130 41983	BC858B
7402▲	5322 130 41982	BC848B
7403▲	5322 130 41982	BC848B
7404▲	5322 130 41982	BC848B
7405▲	5322 130 41982	BC848B
7406▲	5322 130 41982	BC848B
7407	4822 130 40937	BC548B
7408	5322 130 41983	BC858B
7409	5322 130 41983	BC858B
7410	5322 130 41983	BC858B
7411▲	5322 130 41982	BC848B
7412	4822 130 40937	BC548B
7420▲	5322 130 41982	BC848B
7440	5322 209 10883	PCF8574P

**MAINS PANEL CLASSIC LINE [T]**

**Various**

4822 212 11277	Mains Panel (FL6 CL)
▲ 4822 276 13592	Mains switch
▲ 4822 265 30389	Con. 2P
4822 265 31248	Con. 3P (K42)
4822 265 31246	Con. 6P (K41)
▲ 4822 256 91766	LED holder
1600 4822 130 83821	IR receiver GP1U720Q



2601	4822 124 41643	100μF 20% 16V
------	----------------	---------------

2604▲	4822 124 40196	220μF 20% 16V
-------	----------------	---------------

